

TECHNICAL REPORT



Nov 30,
2015

Potential Cost-Effective Flare & Vent Gas Reduction Opportunities
at Selected Production Facilities in Mexico

Prepared For:

*Petroleum Technology Alliance Canada (PTAC)
Suite 400, 500-5th Avenue S.W.
Calgary, AB, T2P 3L5*

Prepared By:

*Clearstone Engineering Ltd.
700, 900-6th Avenue S.W.
Calgary, AB, T2P 3P2*

DISCLAIMER

While reasonable effort has been made to ensure the accuracy, reliability and completeness of the information presented herein, this report is made available without any representation as to its use in any particular situation and on the strict understanding that each reader accepts full liability for the application of its contents, regardless of any fault or negligence of Clearstone Engineering Ltd.

EXECUTIVE SUMMARY

A flare and vent gas measurement program was completed during the period of 29 September to 8 October 2014 at the following selected Petroleos Mexicanos (Pemex) facilities in Mexico:

- CCAC.3 Oil Battery
- CCAC.7 Compressor Station
- CCAC.2 Oil Terminal
- CCAC.6 Oil Battery
- CCAC.1 Oil Battery
- CCAC.5 Oil Battery
- CCAC.4 Oil Battery

Follow-up measurements and technical meetings were conducted at the CCAC.7 Compressor Station on 29 June 2015, and at the CCAC.2 Oil Terminal on 31 August to 1 September, 2015.

The purpose of this study has been, for the surveyed facilities, to identify and delineate practicable flare and vent gas reduction opportunities in terms of their magnitude, most suitable control option, feasibility, greenhouse gas (GHG) emissions reductions, secondary environmental benefits and energy conservation. The surveyed facilities were selected by Pemex, based on an objective screening process, to be representative of sites having large flaring rates (i.e., the CCAC.7 Compressor Station and CCAC.2 Oil Terminal), and highly replicable production facilities having low to moderate flaring and venting rates (i.e., the 5 listed oil batteries).

Specific actions were initiated by Pemex between the 2014 and 2015 measurement campaigns, which have resulted in current and potentially future additional reductions in the amount of gas being flared at CCAC.2 Oil Terminal and CCAC.7 Compressor Station. These reductions are delineated in the “Actions Being Taken” section at the end of this Executive Summary.

As well, it should be noted that a significant decrease in energy pricing occurred between the release of the 2014 report and this final report.

Key Environmental and Economic Analysis Assumptions

All technical, environmental and economic analyses were performed using Clearstone’s web-based source-simulation and data-management application, *CSimOnline*. This program features rigorous process-simulation and data-processing utilities, production

decline models, emission-factor libraries, and detailed time-series benchmarking and economic evaluation features for analysis of process systems and their applicable control options. Moreover, it provides entry-time reasonableness checks of all input data, tracking of data references and calibration records for the applied measurement equipment, as well as standardized reporting of the results. Further details on *CSimOnline* are presented in the Appendices.

Throughout this report, emissions and potential emission reductions are reported in units of tonnes per annum, while process activity levels, natural gas losses and methane losses are all expressed in cubic metres per day. The volumetric flows are referenced at standard conditions of 101.325 kPa and 15°C. The value of avoidable commodity losses and energy consumption are expressed on an annualized basis. All reported GHG emissions include contributions due to CH₄, CO₂ and N₂O emissions. The impact on emissions of selected criteria air pollutants is also considered, including volatile organic compounds (VOCs), SO₂, NO_x, CO, and particulate matter [PM]).

The commodity prices used in the economic analyses were provided by Pemex and are summarized in the table below. All prices presented throughout this report are expressed in US dollars (USD).

Table i: Applied commodity prices.		
Commodity	Value	Units of Measure
Natural Gas	2.59	USD/GJ
Ethane	49.93	USD/m ³ (Liquid)
LPG	0.31	USD/L (Liquid)
Pentanes Plus (C ₅ +))	350.09	USD/m ³ (Liquid)
Hydrogen	N/A	USD/kg
	N/A	USD/m ³
Electricity	0.05	USD/kWh

The value of any potential marketable GHG credits was not considered but would have a positive impact on the practicability of each opportunity. A discount rate of 10% has been used in the economic evaluations. The project life expectancy was assumed to be 20 years for the sites having large flaring rates as these are key Pemex assets in long term service applications. The production facilities were arbitrarily assumed to have a remaining life expectancy of 10 years.

The production decline rate at each of the oil batteries was assumed to be 13.6 percent per year based on recent production data provided by Pemex. Corresponding decline rates were assumed for the assessed venting and flaring rates at these facilities. The assessed

amount of flaring at CCAC.7 Compressor Station and CCAC.2 Oil Terminal was assumed to remain constant with time.

The capital costs of the evaluated control options were prepared by a senior cost estimator and are generally considered to be Class 5 estimates (AACE RP No. 18R-97) (also see Appendix 2). In each case, either detailed estimates were developed based on labour and material requirements and their local costs, or values were assessed on a per-unit throughput basis according to the scale of the application and recent pricing for comparable systems in Canada. The approach taken for each evaluated control option is indicated in the detailed results presented, by source, in the appendices. Piping and instrumentation (P&ID) drawings and plot plans were available for CCAC.7 Compressor Station and were reviewed in developing the detailed capital cost estimates for the evaluated control technologies at that site.

Any fuel withdrawn from the process for use by the applied technologies was assumed to have no direct cost. Any purchased fuels or electric power are treated as an operating expense. Any other operating costs for the evaluated control measures were considered to be relatively small compared to their capital costs and the generated revenues, and, therefore, were set to zero for simplification purposes.

Facilities not already connected to natural gas gathering systems were pessimistically assumed to be uneconomical to tie into any nearby gathering systems, due to a lack of information on local pipelining costs and distances to such gas gathering systems.

The salvage value of control technologies was assumed to be zero at the end of each application, which is potentially also a pessimistic assumption. The specification, where applicable, of modular skid-mounted control technologies that can be easily moved and reused at other sites at the end of a given application will offer improved economics; especially where the opportunity life expectancy at individual facilities is relatively short (e.g., only a few years).

General Control Strategy

The general strategy for conserving or utilizing waste natural gas at production facilities is as follows:

- Utilize the waste gas onsite and at other nearby facilities (especially where this reduces reliance on purchased fuel and other supplied energy such as electricity).
- Recover the Pentanes Plus and LPG fractions and re-inject the residue gas into the oil reservoir for pressure maintenance (i.e., enhanced oil recovery).

- Transport the gas to market by gaining access to a nearby gathering system or convert it into an alternative energy form that can be more readily transported to market (e.g., LNG or electricity).
- Recover valuable LPG and Pentanes Plus fractions from the waste gas streams for delivery to market using the crude oil system (e.g., dissolve the recovered hydrocarbons in the oil) or by other convenient means (e.g., a dedicated NGL transportation system), and use the residue gas to power the extraction process and either meet other onsite fuel needs (including onsite electric power generation if practicable) and flare the balance.
- Pool waste gas from multiple nearby facilities to achieve sufficient volumes to justify conservation or utilization schemes, and achieve improved economies of scale.

The relative value of the different commodities, expressed on an equivalent-energy basis for the pricing indicated in Table i, is presented in the following table:

Table ii: Relative commodity price index expressed on a gross energy basis (HHV).	
Commodity	Value Relative to Processed Natural Gas
Natural Gas	1.0
Ethane	1.0
LPG	4.4
Pentanes Plus (C ₅ +))	3.9
Hydrogen	N/A
Electricity	5.4

These commodity price indexes show that LPG and Pentanes Plus are much more valuable on a per-unit-of-energy basis when extracted from natural gas and marketed separately, than if left in the natural gas and valued based on natural gas pricing (i.e., 4.4 and 3.9 times more valuable, respectively).

The greater value of the condensable fraction (i.e., LPG and Pentanes Plus) is only realized if the waste natural gas is processed to recover these fractions; either onsite or at a downstream gas processing plant. The latter approach offers some cost advantages since it utilizes existing natural gas processing infrastructure, but requires economic access to a natural gas gathering system. The feasibility of processing the natural gas onsite depends on the concentration of condensable hydrocarbons in the natural gas

stream and the scale of the application. Conventional practice has been to recover condensable hydrocarbons from natural gas using a refrigeration- or Joule-Thompson-based condenser system (i.e., a hydrocarbon dew-point control unit) coupled with appropriate front-end compression. Historically, the minimum practicable capacity of these systems has been about 5900 m³/h (140 ×10³ m³/d); however, small-scale systems for processing lesser amounts of natural gas (i.e., less than 42 m³/h [1.0 ×10³ m³/d]) are now available. These small-scale compressor and condenser systems can potentially be feasible even if there is no market for the resulting residue gas (i.e., mostly methane) and the amounts of residue gas in excess of onsite process fuel needs is simply flared. Any residue gas used for fuel and waste residue gas that is flared will be cleaner burning than the initial unprocessed waste gas stream resulting in reduced emissions of black carbon, which is both a powerful climate forcer and an important criteria air contaminant.

The recovered condensed hydrocarbons can be blended with, and held in solution by, the weathered sales oil allowing the commingled product to be transported to market using the existing crude oil transportation systems at no incremental capital cost. Adding the condensed hydrocarbons to the sales oil has the effect of producing a lighter, more valuable, sales product, which also has a lower viscosity making it more efficient to pump. While there is a practical limit to how much LPG and Pentanes Plus can be blended into a weathered sales oil stream without exceeding acceptable vapour pressure limits (e.g., 76 kPa) for products to be stored and handled at atmospheric conditions, this does not significantly limit the practicability of recovering the condensable hydrocarbons from waste associated gas and stock tank vapour streams. This is because the amount of condensable hydrocarbons recovered is generally sufficiently small relative to the amount of sales oil, and if not, this is something that can be managed. A project to recover condensable hydrocarbons from waste associated gas was recently conducted at a production facility in Libya; it reportedly had a 6-month payback period even though the residue gas in excess of onsite fuel demands was simply flared. Moreover, the application essentially eliminated the significant black smoke emissions that had been occurring from flaring the unprocessed waste gas.

If the sales oil is transported to market or to a central processing facility by pipeline without having to go through storage tanks at intermediate locations, then a product having a much greater vapour pressure can be produced without the risk of losing product due to flashing losses or producing a gas phase in the oil pipeline, which could potentially cause pumping problems.

Ultimately, upon reaching the refinery the oil will be fractionated and refined, so the value of the different commodity fractions recovered from the waste gas will be realized there.

Converting natural gas to electricity can also be financially attractive, especially if this displaces purchased electric power and any economic-to-recover condensable fractions are removed from the gas first. If the amount of electricity that would be produced exceeds the onsite demands then the feasibility of using waste gas to produce electric power will depend on the conversion costs, efficiencies achieved and market access costs.

Liquefying the natural gas is an option in stranded gas applications, but generally requires relatively large-scale applications to be economical. At facilities connected, or having economic access, to a gas gathering system, the most practicable option is generally to conserve the gas by producing it into the gathering systems where it can be sent to the downstream processing facilities. Excessive flaring due to inefficient flare designs at facilities having access to natural gas gathering systems is best managed through preventative measures such as upgrading to more efficient designs and managing leakage into the flare headers and eliminating any bottlenecks that may be contributing to the flaring.

Measurement and Testing Program

The flare gas measurement work comprised inline tracer tests to determine the time-series flare gas rate for each active flare at each visited facility. The duration of the time-series flow measurement of each flare gas stream was typically at least 1 to 2 hours, or such longer periods as were needed to properly characterize the flow variability. One oil battery, the CCAC.6 Oil Battery, had no measurable flaring. Only CCAC.7 Compressor Station, CCAC.2 Oil Terminal, and CCAC.4 Oil Battery were connected to a gas gathering system.

Flare CB102B at CCAC.7 Compressor Station only potentially flares gas for 4 hours each day, which is scheduled to occur during the afternoon to dispose of waste gas from operation of the blowcase system on the compressor scrubbers. Flare CB102B is equipped with a flare-gas recovery compressor, which, when in operation, was shown to be effective in recovering all the gas from the blowcase venting activity; however, this compressor was out of service in 2014 and exhibited some reliability issues when the system was re-inspected in 2015. All other flares were in continuous service.

Safe access to the vents on the crude oil production tanks at each oil battery was not available, so the emissions from these sources were estimated based on rigorous process simulations using site-specific activity data and process operating conditions.

Emissions Reduction and Energy Conservation Opportunities

As shown in Table iii, opportunities for gross baseline savings of 48.3 million USD/y and baseline emission reductions of 496.9 kt CO₂E/y were identified in 2014. Updating of these results in 2015 to reflect the actions already taken by Pemex since the first measurement campaign show current remaining opportunities for gross baseline savings of \$16.1 million USD/y (see Figure i) and baseline emission reductions of 171.4 kt CO₂E/y (see Figure ii). Thus, the actual reductions achieved thus far, based on the actions taken by Pemex between 2014 and 2015, amount to a savings of \$32.2 million USD/y and baseline emission reductions of 325.5 kt CO₂E/y. If sustained, the impact of the actions taken to date will result in a net present savings of \$284.2 million USD and a net lifetime emissions reductions of 6,345.6 kt CO₂E being realized.

It is estimated that the net present value of implementing all remaining practicable control options, based on the current 2015 results, would be \$43.4 million USD (see Figure iii). This would result in a corresponding net lifetime GHG emissions reduction of 1,835.7 kt CO₂E (see Figure iv), which represents an overall reduction of 77.8 percent in the lifetime GHG emissions from all the assessed sources. The results for the oil batteries have not been extrapolated across all facilities (i.e., due to a lack of a total count of equivalent facilities); doing so would result in increased values and increase the relative contribution of tanks.

Table iii: Comparison of 2014 and 2015 measurement results, and summary of the actual GHG emission reductions achieved through control actions taken by Pemex.				
Measurement Campaign	Baseline Value Of Flare & Vent Gas (Million USD/y)	Baseline GHG Emissions (kt CO₂E/y)	Net Present Value of Practicable Reduction Opportunities (Million USD)	Net Practicable Lifetime GHG Emission Reduction Potential (kt CO₂E)
2014	48.3	496.9	327.6	8,181.3
2015	16.1	171.4	43.4	1,835.7
Actual Reductions/Benefits Achieved	32.2	325.5	284.2	6,345.6

The main cost-effective opportunity to further reduce emissions and conserve energy at the visited facilities is conserving the flare gas. The payback periods for the remaining cost-effective flaring reduction opportunities ranged from 0.3 to 5.7 years. The opportunities for cost-effective vapour recovery were much less significant in terms of total emissions reduction and, with the current low energy prices, generally have payback periods in excess of the anticipated project life (i.e., greater than 10 years). The small

relative emission contribution from vapour recovery is largely due to the significant flaring contributions by CCAC.7 Compressor Station and CCAC.2 Oil Terminal.

The most financially attractive and significant opportunities occur at the CCAC.7 Compressor Station and CCAC.2 Oil terminal. This reflects the fact both facilities were connected to natural gas-gathering systems, which helps to reduce conservation costs, and had favorable economies of scale due to the relatively large amounts of flaring at these sites. Opportunities to reduce purge gas and/or pilot gas consumption offered quite low payback periods (1.3 years or better) due to the simple nature and low capital cost of the applicable control measures, but these opportunities require a major facility shutdown to implement and, therefore, would need to be delayed until such an event occurs.

The results for the oil batteries were determined to be very sensitive to the assessed amount of flaring and venting, the assumed production decline rate and, to a lesser extent, the facility life expectancy. Given the lack of information on accessible gas gathering systems, the preferred solution at sites with moderate amounts of flaring was to recover the condensable fractions of the waste natural gas streams using small-scale condenser systems, and to use the residue gas to power the process with the balance of the residue gas being flared. Choosing modular skid-mounted condenser systems that can be easily moved to other facilities for continued use once the life of the current application has expired, or associated gas volumes have dropped below economic thresholds, will help improve the economics. Given the limited experience of Pemex with such technologies, a demonstration project would be helpful to better define the practicability of the technology at its production facilities. The technology may also be useful to consider for application at refineries and petrochemical facilities that have continuous flare gas streams rich in condensable hydrocarbons that cannot be practicably avoided. Unfortunately, given the current low price of oil and gas, none of the flare gas reduction opportunities identified at oil batteries offer payback periods of less than 4 years and, therefore, do not meet current investment hurdle rates at this time.

Two of the surveyed oil batteries did not have sufficient gas volumes being flared to be cost effective to control regardless of the project life (i.e., CCAC.6 Oil Battery and CCAC.1 Oil Battery).

The conservation of solution gas from storage tanks is generally only practicable at oil production facilities where associated gas production is already being conserved (e.g., at CCAC.4 Oil Battery) or where conservation of the solution gas can be combined with a practicable project to conserve the associated gas.

Any ranking of the identified opportunities needs to consider the evaluation criteria of the financing that would be obtained to undertake the projects. Generally, energy conservation and environmental projects only proceed if they are driven by regulatory requirements; they do not compete effectively (regardless of their profitability) against traditional exploration and drilling projects that increase reserves and infrastructure projects that increase production. Increased reserves and overall profitability are the key parameters upon which the market evaluates energy companies, and a company's socioeconomic and environmental performance, often, either are given less importance or are more challenging to quantify. Accordingly, it is expected that the identified project opportunities will only proceed through access to green bonds and other non-traditional capital funds specifically dedicated for environmental and energy conservation projects. In these cases, not only is the return on investment a consideration, but so also is the amount of GHG emission reductions achieved and secondary benefits such as local air quality improvements and socio-economic factors such as job creation and stimulation of the local economy.

Implementation Costs and Benefits

Preliminary capital costs have been assessed for the identified flare and vent gas reduction opportunities. Additional analysis of these opportunities may be appropriate after they have been confirmed and prioritized.

Additionally, the practicability of providing access to nearby gas-gathering systems should be considered for all oil batteries with potentially economic volumes of associated and solution gas being vented or flared.

Actions Being Taken

Since the 2014 measurement campaign, management at the CCAC.2 facility has undertaken the following measures to address the identified opportunities:

- Flare CCAC.2.2: the noteworthy flaring rates associated with this flare (i.e., 12,700 m³/h worth \$21.885 million annually, based on commodity pricing, and resulting in 270.3 kt/y of CO₂E emissions), was attributed to the use of excessive purge gas to help mitigate reliability issues with the flare igniter system and ensure the flare remained lit. The flare was briefly taken out of service to allow the igniter system to be replaced, which has, reportedly, virtually eliminated the residual flaring associated with that source. Accordingly, the flare is assumed to be operating at its minimum required purge gas requirement of 51.1 m³/h which is worth \$0.1 million annually and contributes 1.4 kt/y of CO₂E emissions).

- Flare CCAC.2.3: the flaring from this source (i.e., 432.3 m³/h worth \$2.2 million annually, based on commodity pricing, and resulting in 15.8 kt/y of CO₂E emissions), was attributed to a system bottle-neck, namely, the lack of adequate compression to capture all of the off-gas from the crude oil stabilization process and send it to the onsite gas processing facility. A project has since been awarded to the Mexico Petroleum Institute (IMP or Instituto Mexicano del Petróleo) to prepare the necessary engineering design for the additional required compression. Currently, 8 reciprocating compressors are used to capture the off-gas from the crude oil stabilizer with the balance of the off-gas going to flare. It is estimated that 3 additional compressors will be needed to meet the total baseline capacity requirement.
- Flare CCAC.2.4: the flaring from this source (i.e., 2,270 m³/h worth \$7.7 million annually, based on commodity pricing, and resulting in 70.1 kt/y of CO₂E emissions), was attributed to a system bottleneck that precluded all of the associated gas production from the inlet separator at the terminal being compressed into the gas gathering system. The gas gathering system feeds into several major gas processing plants. A project has been awarded to IMP to prepare the necessary engineering design for the installation of a centrifugal compressor to meet the additional compression requirements.

At the time of the August 2015 visit, an incident had occurred at an offshore production platform, which required large additional amounts of gas to be diverted to the CCAC.2 Oil Terminal. Repeat measurements were performed on all three flares at that time; however, the results showed flaring rates much greater than normal operation for all three flares. The total amount of gas being flared at that time was 347,259 m³/h worth \$456.8 million, based on commodity pricing, and resulting in 10,059 kt/y of CO₂E emissions.

Management at the CCAC.7 facility have undertaken the following measures to address the identified opportunities there:

- Flare CCAC.7.19: A blowcase gas recovery compressor existed to capture and conserve the waste gas from blowcase depressurization events. The compressor had previously been taken out of service due to maintenance issues and then was not put back into service. Based on the results of the 2014 measurement campaign, repairs were made to the compressor and it was shown to be achieving complete capture of the blowcase depressurization off-gas flows when operating (i.e., zero flow to Flare CCAC.7.19 was measured), resulting in avoided gas losses of 536.9 m³/h worth approximately \$0.9 million annually and corresponding emission reductions of 10.8 kt/y of CO₂E. This was confirmed by the measurements performed in June 2015; however, a problem did arise that

caused the compressor to shut down shortly before the end of the measurements and for flaring by Flare CCAC.7.19 to resume. This indicates that the maintenance issue may not have been fully resolved and further efforts to address the matter may be needed.

- Flare CB104A: Some efforts were made to identify and fix valves determined to be leaking into the flare system. These efforts reduced the concentration of non-methane hydrocarbons in the flare stream but did not substantively change the flow rate. Nonetheless, this results in an estimated net savings of \$0.2 million USD annually and net GHG emission reductions of 0.6 kt/y of CO₂E. The effectiveness of these measures demonstrates the benefits of a formal program to manage leakage into flare systems. Additional reductions could be achieved by redesigning the flare to minimize purge gas requirements without compromising the flare reliability.

No actions are reported to have occurred at the oil batteries located near Poza Rica; however, Pemex has indicated plans to examine opportunities at additional facilities in the area, and to re-direct flare and vent gas in urban areas to central facilities where it could be conserved. Moreover, the results presented herein are a more refined analysis which considers updated commodity pricing and operating costs.

**Gross Value of Assessed Baseline
Hydrocarbon Losses
(16.1 Million USD/y)**

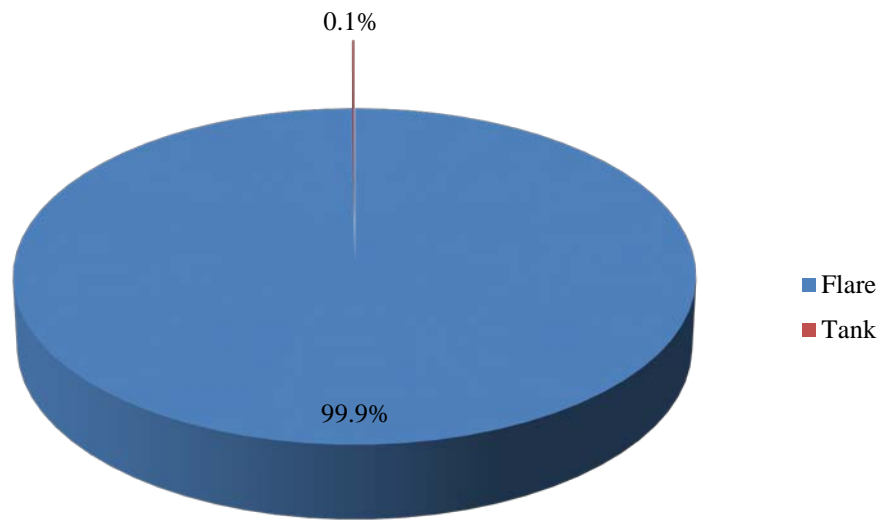

Figure i: A pie chart depicting the percentage contribution, by primary source category, to the gross baseline savings potential of the assessed control opportunities at the surveyed facilities.

**Assessed Baseline GHG Emissions
(164.7 kt CO₂E/y)**

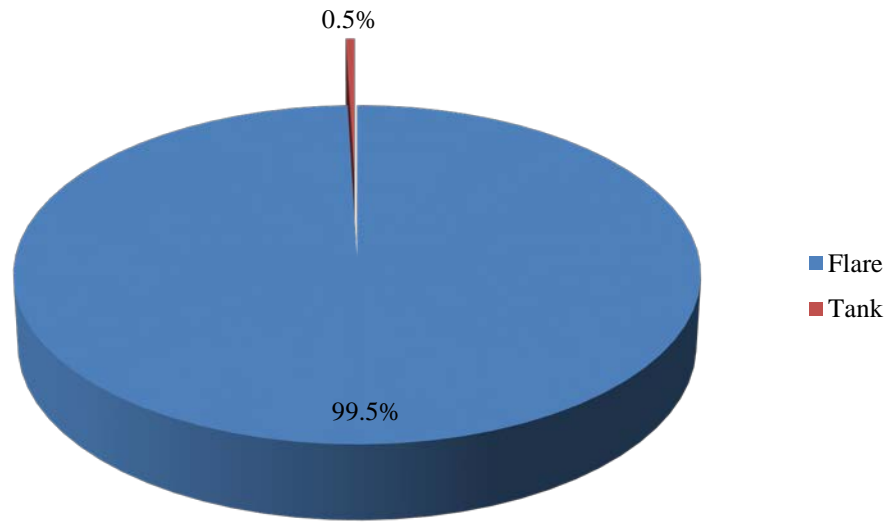

Figure ii: A pie chart depicting the percentage contribution, by primary source category, to baseline GHG emissions by the assessed control opportunities at the surveyed facilities.

Net Present Value of Practicable Reduction Options (42.0 Million USD)

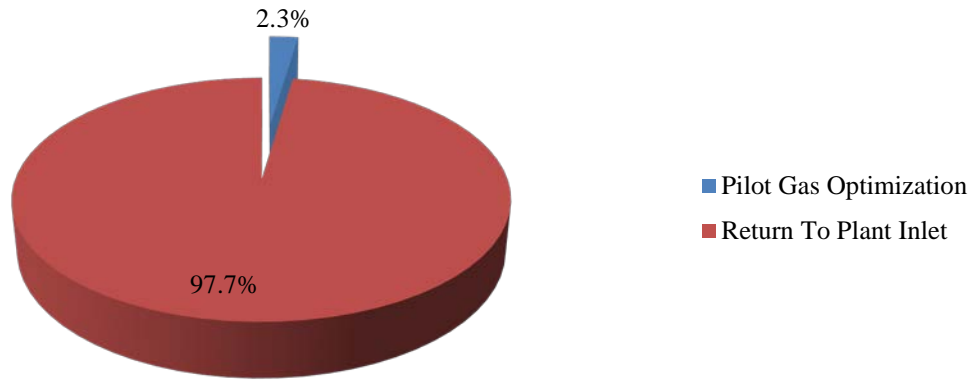

Figure iii: A pie chart depicting the percentage contribution, by control technology, to the net present value of the assessed practicable control opportunities at the surveyed facilities.

**Practicable Lifetime GHG Reduction
Potential
(1,600.4 kt CO₂E)**

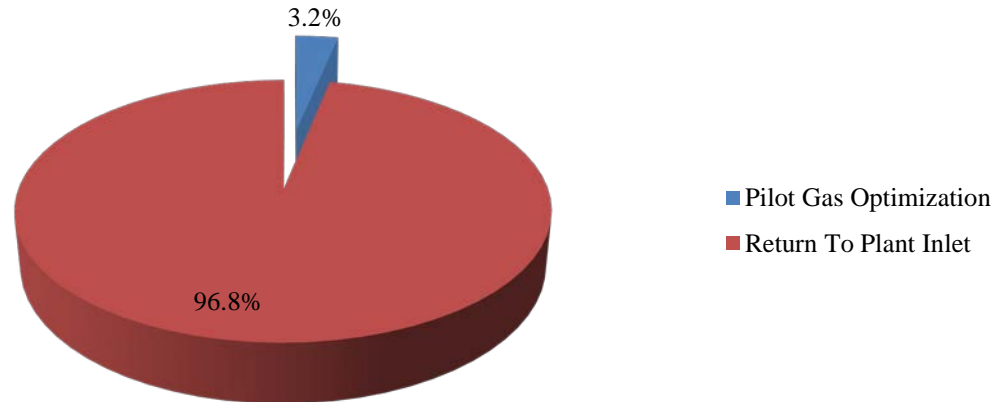

Figure iv: A pie chart depicting the percentage contribution, by control technology, to the lifetime GHG emissions reduction potential of the assessed practicable control opportunities at the surveyed facilities.

TABLE OF CONTENTS

DISCLAIMER	i
EXECUTIVE SUMMARY	ii
TABLE OF CONTENTS	xvii
LIST OF TABLES	xx
LIST OF FIGURES	xxi
LIST OF ACRONYMS	xxii
1 INTRODUCTION	1
1.1 Background.....	2
1.2 Objectives	3
1.3 Study Approach	4
2 PRACTICABLE REDUCTION OPPORTUNITIES	5
2.1 Waste Gas Flares.....	5
2.2 Storage Losses	17
3 CONCLUSIONS AND RECOMMENDATIONS	22
3.1 Conclusions.....	22
3.2 Recommendations.....	22
4 REFERENCES CITED	23
5 APPENDIX - GLOSSARY	24
6 APPENDIX - ECONOMIC EVALUATION METHODOLOGY	56
6.1 Cost Estimating.....	57
6.1.1 Capital Costs.....	57
6.1.2 R&D Costs	61
6.1.3 Operating Costs.....	61
6.1.4 Removal Costs	63
6.1.5 Decommissioning Costs and Salvage Value.....	63
6.2 Determination of Costs Avoided and Revenues Produced	63
6.2.1 Commodity Pricing	64
6.2.1.1 Determination of the Higher Economic Value of an Energy Stream.....	65
6.2.1.2 Determination of the Lower Economic Value of an Energy Stream	65
6.2.2 Determination of the Net Operating Cost	66
6.2.3 Emission Taxes and Tradable Permits	66
6.3 Project Life.....	67
6.4 Financial Rates	67
6.4.1 Discount Rate.....	67
6.4.2 Other Discount Rates	67
6.4.3 Inflation Rates	68
6.5 Economic Analysis	68
6.5.1 Net Present Value (NPV).....	68

6.5.2	Return on Investment (ROI)	69
6.5.3	Payback Period	69
6.6	Production Decline Rates	70
6.7	References Cited	72
6.8	Results	72
7	APPENDIX - TECHNICAL & ENVIRONMENTAL ANALYSIS	
	METHODOLOGY	73
7.1	Technical Evaluation	74
7.1.1	Input Data Management and Transparency	74
7.1.1.1	Quality Control and Quality Assurance Measures	74
7.1.2	Process Simulations	75
7.1.2.1	Flowsheet Simulator	75
7.1.2.2	THERMOdynamic Engine	75
7.1.2.3	Fluid Property Prediction	76
7.1.2.4	Pipeline Simulations	76
7.1.3	Equipment Sizing	77
7.1.4	Equipment Performance Benchmarking	78
7.1.5	Evaluation of Control Technologies	78
7.2	Environmental Evaluations	78
7.3	Basic CsimOnline Architecture	79
7.3.1	Process Streams	79
7.3.2	Process Unit or Major Equipment Unit	80
7.3.3	Process System	80
7.3.4	Control Technologies	80
7.3.5	Facilities	80
7.4	References Cited	83
8	APPENDIX - FLARE AND VENT SYSTEMS	85
8.1	Introduction	85
8.2	Flare and Vent Gas Flow Rate Determination	86
8.2.1	Installed Flow Meters	88
8.2.2	Independent Flow Measurements	90
8.2.2.1	Velocity Probe	90
8.2.2.2	Inline Tracer Test	93
8.2.2.3	Flow Estimation Based on Flare Flame Length	95
8.3	Flare and Vent Gas Analysis	97
8.4	Flare Optimization	97
8.4.1	Management of Fuel Consumption by Flares	98
8.4.1.1	Purge Gas Consumption	98
8.4.1.2	Determination of Minimum Purge Gas Requirements	99
8.4.2	Pilot Gas Consumption	101
8.4.3	Make-up Gas Consumption	102
8.4.4	Management of Flare Reliability and Destruction Efficiency	102
8.4.4.1	Minimum Energy Content of Combined Flare Volume	102

8.4.4.2	Flare Efficiency	103
8.4.4.2.1	Calorific Correction	103
8.4.4.2.2	Wind Speed Correction.....	105
8.4.4.3	Steam-Assisted Flare.....	105
8.4.4.4	Air-Assisted Flare	108
8.5	Flare and Vent Gas Control Options.....	110
8.5.1	Incinerators	110
8.5.2	Auto-Ignition System.....	111
8.5.3	Smokeless Flares.....	112
8.5.4	Management of Leaking Flare Valves	113
8.5.5	Flare Gas Recovery System	114
8.5.6	Production Into a Nearby Gas Gathering System.....	115
8.5.7	Production of Electric Power	117
8.5.7.1	Reciprocating Engines.....	118
8.5.7.2	Micro-Turbines	119
8.5.7.3	Gas Turbines	121
8.5.8	Extraction of Condensable Hydrocarbons	122
8.6	References Cited	131
8.7	Results.....	132
9	APPENDIX - STORAGE TANKS.....	214
9.1	Introduction.....	214
9.2	Storage Loss Determination.....	214
9.2.1	Evaporation Losses From Weathered or Stabilized Products.....	215
9.2.2	Flashing Losses	216
9.2.2.1	Direct Measurements.....	217
9.2.2.2	Estimation Techniques	218
9.2.3	Unintentional Gas Carry-Through	218
9.2.4	Blanket Gas Emissions	219
9.2.4.1	Direct Measurement	220
9.2.5	Estimation Techniques.....	221
9.3	Vapour Analysis.....	222
9.4	Control Options.....	222
9.4.1	Tanks Containing Weathered or Stabilized Product.....	223
9.4.2	Tanks Containing Unweathered or Unstabilized Products	223
9.5	References Cited	227
9.6	Results.....	227
10	APPENDIX - GAS & VAPOUR ANALYSES	260

LIST OF TABLES

TABLE 1: BASELINE COMMODITY LOSSES ASSOCIATED WITH FLARING AT THE SURVEYED PEMEX FACILITIES.	7
TABLE 2: BASELINE ANNUAL ATMOSPHERIC EMISSIONS OF CH ₄ , CO ₂ , N ₂ O CO ₂ E, VOC, CO, NO _x , SO ₂ AND PM DUE TO FLARING AT THE SURVEYED PEMEX FACILITIES.	8
TABLE 3: LIFETIME ECONOMIC ANALYSIS OF APPLYING THE MOST PROMISING COST-EFFECTIVE CONTROL TECHNOLOGY TO THE FLARES AT EACH SURVEYED PEMEX FACILITY.....	9
TABLE 4: LIFETIME ATMOSPHERIC EMISSION REDUCTIONS DUE TO APPLICATION OF THE MOST PROMISING COST EFFECTIVE CONTROL OPTIONS TO THE FLARES AT THE SURVEYED PEMEX FACILITIES.....	11
TABLE 5: BASELINE COMMODITY LOSSES ASSOCIATED WITH VENTING OF SOLUTION GAS FROM PRODUCTION STORAGE TANKS AT THE SURVEYED PEMEX OIL BATTERIES.....	18
TABLE 6: BASELINE ANNUAL ATMOSPHERIC EMISSIONS DUE TO VENTING OF SOLUTION GAS FROM PRODUCTION STORAGE TANKS AT THE SURVEYED PEMEX OIL BATTERIES.	19
TABLE 7: LIFETIME ECONOMIC ANALYSIS OF RECOVERING THE VAPOURS FROM THE PRODUCTION STORAGE TANKS AT THE SURVEYED PEMEX OIL BATTERIES AND COMMINGLING IT WITH THE ASSOCIATED GAS FOR PROCESSING USING THE ASSOCIATED GAS CONTROL TECHNOLOGY.....	20
TABLE 8: LIFETIME REDUCTION IN ATMOSPHERIC EMISSIONS DUE TO APPLICATION OF ALL COST-EFFECTIVE VAPOUR RECOVERY APPLICATIONS. ¹	21
TABLE 9: ESTIMATE CLASSIFICATION SYSTEM AS APPLIED IN ENGINEERING, PROCUREMENT AND CONSTRUCTION FOR THE PROCESS INDUSTRIES.	58
TABLE 10: EQUATIONS OF STATE IMPLEMENTED IN <i>THERMOENGINE</i> AND THE TARGET CHEMICAL SYSTEMS TO WHICH THEY ARE APPLIED.	76
TABLE 11: SUMMARY LISTING OF POTENTIAL METHODOLOGIES FOR DETERMINING VENT AND FLARE RATES.	86
TABLE 12: TYPICAL MINIMUM PURGE RATES TO AVOID UNSAFE AIR INFILTRATION.	101
TABLE 13: AVERAGE FUEL GAS CONSUMPTION FOR ENERGY-EFFICIENT FLARE PILOTS ¹	102
TABLE 14: SUMMARY OF TYPICAL COST CATEGORIES TO BE CONSIDERED IN EVALUATING GAS CONSERVATION SCHEMES.	116
TABLE 15: SUMMARY OF WAUKESHA GASEOUS FUEL SPECIFICATIONS (S7884-7, 3/03).	119
TABLE 16: SUMMARY OF TYPICAL GASEOUS FUEL SPECIFICATIONS FOR A MICRO-TURBINE.	120
TABLE 17: SUMMARY OF TYPICAL GASEOUS FUEL SPECIFICATIONS FOR SOLAR TURBINES.....	121
TABLE 18: COMPARISON OF THE RECOVERY AND ENERGY EFFICIENCY OF COMMON REFRIGERATION PROCESSES FOR A TYPICAL NATURAL GAS MIXTURE CONTAINING 97% METHANE.	125
TABLE 19: COMPARISON OF THE RECOVERY AND ENERGY EFFICIENCY OF COMMON REFRIGERATION PROCESSES FOR A TYPICAL NATURAL GAS MIXTURE CONTAINING 85% METHANE.	126
TABLE 20: COMPARISON OF THE RECOVERY AND ENERGY EFFICIENCY OF COMMON REFRIGERATION PROCESSES FOR A TYPICAL NATURAL GAS MIXTURE CONTAINING 73% METHANE.	127
TABLE 21: PERCENTAGE OF THE RESIDUE GAS PRODUCED BY SELECTED LIQUIDS RECOVERY TECHNOLOGIES, AND FOR DIFFERENT FIELD GAS COMPOSITIONS, THAT MAY POTENTIALLY BE UTILIZED TO POWER THE PROCESS.....	128
TABLE 22: MINIMUM CRUDE OIL FLOW REQUIREMENT TO PREVENT TWO-PHASE FORMATION IN THE CRUDE OIL PIPELINE EXPRESSED AS A FUNCTION OF THE AMOUNT OF WASTE GAS PROCESSED TO RECOVER CONDENSABLE HYDROCARBONS (M ³ CRUDE OIL PER DAY / 10 ³ M ³ OF WASTE GAS PROCESSED PER DAY).	131
TABLE 23: SUMMARY LISTING OF POTENTIAL METHODOLOGIES FOR DETERMINING VENT AND FLARE RATES.	216

LIST OF FIGURES

FIGURE 1: PHOTOGRAPHS, FROM LEFT TO RIGHT, OF FLARES CCAC.2.2, CCAC.2.3 AND CCAC.2.4 AT THE CCAC.2 OIL TERMINAL, 29 TO 30 SEPTEMBER 2014.	13
FIGURE 2: PHOTOGRAPH OF THE FLARE AT THE CCAC.3 OIL BATTERY, 8 OCTOBER 2014.	14
FIGURE 3: PHOTOGRAPH OF FLARE CCAC.7.19 AT THE CCAC.7 COMPRESSOR STATION, 2, OCTOBER 2014.	15
FIGURE 4: PHOTOGRAPHS OF FLARE CCAC.7.9 AT THE CCAC.7 COMPRESSOR STATION, 2 OCTOBER 2014.	16
FIGURE 5: WORK FLOW DIAGRAM DEPICTING THE BASIC FUNCTIONALITY OF CSIMONLINE.	81
FIGURE 6: WORK FLOW DIAGRAM DEPICTING THE CONTROL TECHNOLOGY SELECTION, SIZING AND EVALUATION PROCESS.	82
FIGURE 7: SCHEMATIC DIAGRAM DEPICTING A PAIR OF ULTRASONIC FLOW TRANSDUCERS WETTED TO THE FLOW IN A PIPE.	89
FIGURE 8: PHOTOGRAPH OF AN OPTICAL FLOW METER PROBE.	90
FIGURE 9: A PHOTOGRAPH OF ONE FLARE FLAME SHOWING THE RELATED DIMENSIONS FOR THE FLAME LENGTH APPROACH.	97
FIGURE 10: PROCESS FLOW DIAGRAM OF A JOULE-THOMPSON (JT) PLANT FOR RECOVERY OF NON-METHANE HYDROCARBONS FROM NATURAL GAS STREAMS.	129
FIGURE 11: PROCESS FLOW DIAGRAM OF A MICRO-CONDENSER SYSTEM USED TO EXTRACT CONDENSABLE HYDROCARBONS FROM ASSOCIATED GAS AND VAPOURS FROM THE PRODUCTION TANK AT A TYPICAL OIL PRODUCTION FACILITY.	130
FIGURE 12: A PHOTOGRAPH OF A TYPICAL VAPOUR RECOVERY TOWER ELEVATED ABOVE THE STORAGE TANK.	225
FIGURE 13: PIPING AND INSTRUMENTATION DIAGRAM OF A VAPOUR RECOVERY SYSTEM FEATURING A VAPOUR RECOVERY TOWER.	226

LIST OF ACRONYMS

CAPP	-	Canadian Association of Petroleum Producers
CCAC	-	Climate and Clean Air Coalition
GHG	-	Greenhouse Gas (CO ₂ , CH ₄ , N ₂ O, SF ₆)
HHV	-	Higher Heating Value
LHV	-	Lower Heating Value
MJ	-	Megajoule
NAMA	-	Nationally Appropriate Mitigation Action
Ng	-	Nanogram
NPV	-	Net Present Value
RISE	-	Research Institute of Safety and Environmental Technology
ROI	-	Return on Investment
THC	-	Total Hydrocarbons
USD	-	US Dollars

ACKNOWLEDGEMENTS

The assistance and cooperation of the following individuals is gratefully acknowledged:

- PEMEX's subdirectorates and their heads, along with Ruben Ostos, Marco Jimenez, Javier Bocanegra and Roberto Nanga.
- Staff at the visited Pemex facilities.
- Francisco Sucre (GGFR)

The financial support of CCAC and GGFR, and the kindness and help provided by all the staff at the surveyed facility are gratefully acknowledged.

1 INTRODUCTION

This report presents the results of a study to identify and evaluate opportunities to cost-effectively reduce greenhouse gas (GHG) emissions through flare and vent gas reduction at a representative sample set of 5 oil production facilities, a major oil terminal and a large gas gathering compressor station in Mexico. A key objective was to provide reliable quantitative information for consideration in the potential development of a nationally appropriate strategy for managing flaring and venting in Mexico's oil and natural gas industry.

The key benefits of the identified opportunities include increased profits, improved overall energy efficiencies, conservation of a valuable non-renewable resource, reduced GHG emissions, reduced air pollution and both national and international recognition.

Some of the common reasons that significant cost-effective GHG reduction and energy efficiency improvement opportunities may exist at oil and natural gas facilities are:

- Changes in operating conditions from initial design values.
- Capital constraints during initial design and construction of process systems resulting in reduced gas conservation and overall energy efficiencies.
- Progressive deterioration of equipment performance.
- Outdated designs that are based on previous low energy prices.
- Use of outdated technologies.
- Lack of quantitative data to build business cases for improvement opportunities.
- Difficulty in competing for available capital investment funds against traditional exploration, drilling and infrastructure projects.

The main advantages of conducting an independent emissions review are:

- Transparent compilation of detailed data needed to design a solution and develop a credible business case.
- Fresh views and insights coupled with the knowledge and experience of the review team.
- Independent verification and benchmarking of a facility's performance.
- Transparent third-part determination of the emissions baseline.
- An opportunity for technology transfer to, and training of, facility staff.
- Access to specialized testing, measurement and analytical technologies that are not readily available to the facility staff.

Additionally, the review provides the means to monitor performance over the long term by comparing performance against the baseline established at the time of the initial facility survey. This process, or benchmarking, can be applied at the facility level as well as at the individual

process unit level. The following sections present a summary and discussion of the key evaluation results (Section 2) and conclusions and recommendations (Section 3), and references cited (Section 4). A glossary of key terminology is provided in Appendix 5. Details of the methodology used to conduct economic evaluations are presented in Appendix 6. Appendix 7 delineates the applied technical and environmental evaluation methodology. The next two appendices (Appendix 8 and 9) present, by type of source (flares and vents, as well as storage tanks), details of the applied measurement techniques, benchmarking calculations, control options and detailed results. The detailed composition data use for all relevant process streams and the basis for the data are presented in Appendix 10.

1.1 BACKGROUND

The flaring of associated gas in Mexico has fluctuated in the past. The last large increase occurred in 2008, when volumes of flaring reached an alarming figure of 13 billion cubic meters (from less than 2 bcm in 2004, placing Mexico in the top 5 flaring countries). According to Petroleos Mexicano (Pemex) officials, in the past, flaring has suffered cyclical fluctuations. Although most of the flaring occurs in two major offshore facilities, i.e. Cantarell and Ku Maloob Zaap, there are eight other operational centers that, combined, contribute 77% of the national upstream flaring. Flaring levels, nevertheless, have significantly dropped (by 66%) since 2008, reaching a level of 1.30 bcm in 2012 (the lowest point in the last 10 years).

Due to the sudden spike in flaring that occurred in 2008, the Secretaria de Energy (Energy Ministry, SENER) ordered Pemex to partner with GGFR to focus on the situation. In 2009 Pemex joint and implemented an aggressive program (mostly in the Cantarell field) and managed to reduce flaring to 10 bcm in 2010 and 6 bcm the following year. As part of the effort of SENER, the newly established National Hydrocarbon Commission (CNH) enacted the first flaring and venting guidelines, which mandated Pemex to gradually reduce flaring through the establishment of a flaring ceiling or cap. Thus far, Pemex has been able to reach CNH targets.

There are multiple causes that affect flaring activity in Mexico. The most important ones include: (i) limited allocation of capital to marginal investment projects dedicated to associated gas recovery (Capex competes with much more lucrative oil producing investments); (ii) lack of effective planning between upstream operations (owner of the flared gas) and downstream affiliates (gas processing and refineries), which are the ones capable of transforming the wasted gas into valuable products (i.e. LPG, natural gas, liquids, power, heat, etc.); (iii) insufficient regulatory pressure (this has improved); (iv) poor measurement of flare gas (limiting an accurate understanding of the problem); (v) weak top management direction and accountability (this is also improving); and (vi) reconciliation of flaring volumes with oil production targets (maintaining oil production sometimes has caused Pemex to allow more flaring, this has been particularly true in large fields such as Cantarell and Ku Maloob Zaap). The reasons why flaring has successfully gone down include: greater allocation of CAPEX to flaring reduction

(approximately 1.1 billion US\$ in 2011), more management commitment and attention devoted to flaring reduction, greater and more effective monitoring and supervision by the national regulator (CNH), and somewhat improved communication between Pemex's subsidiary productive companies (EPS) involved in natural gas production and processing.

Mexico joined the Global Gas Flaring Reduction (GGFR) partnership in 2009, with representation by both the Government of Mexico (represented by SENER) and Pemex corporate HSE unit. From the start, Mexico has proved to be highly committed to tackle the problem. Efforts have included a thorough study of flaring situation in Cantarell and Ku Maloob Zap (gas handling assurance review); a high visibility forum in which the Minister of Energy and Pemex top upstream Director participated; and the implementation of several workshops dealing with flare management, measurement and gas utilization options.

Mexico has reiterated its commitment to continue improving its flaring reduction efforts, by confirming its participation and contribution to Phase IV of GGFR. Since flaring levels have been reduced so drastically, further recovering associated flared gas will require dedicated work from the part of the government and Pemex.

1.2 OBJECTIVES

Pemex Health, Safety and Environmental division, as well as the Exploration and Production Planning and Transport and Commercialization divisions are interested in identifying potential flare reduction projects at its facilities.

The overall aim of this study has been the identification of the appropriate technical solutions for the use of associated flare gas, and the preparation of a prefeasibility study for one or two potential projects.

The main objectives have been:

- To review and analyze the existing situation of upstream flaring sites in Mexico (particularly in the vicinity of Poza Rica);
- To identify and analyze the alternative options of associated gas utilization, in terms of viable technologies and business schemes;
- To conduct a prefeasibility assessment of investment projects (at least 2) in the form of specific "case studies" appropriate for the most suitable technologies;
- To conduct capacity building under the framework of this study (during the start and when results of the study will be presented to Pemex, SENER and CNH);

1.3 STUDY APPROACH

An objective screening process was undertaken in collaboration with Pemex to identify facilities that either had significant amounts of venting and flaring, or were highly replicable. The data needed for the screening process were collected through direct contacts with the asset teams of Pemex facilities.

A measurement study was conducted at the selected sites to develop a list of practicable flare and vent gas management projects.

A preliminary prefeasibility study was conducted for each identified opportunity, based on expected investment costs and energy tariff forecasts. The environmental benefits that will arise from the implementation of such projects is highlighted. The analysis includes the potential application of carbon credits revenues either within a framework of the nationally appropriate mitigation actions (NAMA1) or as standalone type of carbon finance project (e.g. based on the Clean Development Mechanism (CDM) or the voluntary market).

¹ NAMAs are policies, programmes and projects that developing countries undertake to contribute to the global effort to reduce greenhouse gas emissions. Developed countries have committed to supporting meaningful mitigation actions in developing countries through financing, technology transfer and capacity building. The policy framework around NAMAs is still being developed but NAMAs are set to become a building block for a future climate agreement

2 PRACTICABLE REDUCTION OPPORTUNITIES

This section delineates the total assessed hydrocarbon losses, by source and facility, as well as all practicable opportunities identified for reducing these losses. Complete details on all of the opportunities that were considered, including those determined to be uneconomical, are presented in the Venting & Flaring and Storage Losses Appendices (i.e., Appendix C and D, respectively).

2.1 WASTE GAS FLARES

Table 1 presents the baseline hydrocarbon losses, by commodity type, associated with the assessed flaring of waste natural gas at each of the visited facilities. Table 2 presents the estimated baseline atmospheric emissions from this flaring. The detailed results and assessment methodology are presented in Appendix 8 (Flares and Vents).

Table 3 presents the lifetime economic analysis results for application of only the most promising cost-effective control options. Entries of “---“ indicates that either no cost-effective control options were identified for the given source or there was negligible gas flow to the given flare. The lifetime emission reductions reasonably achievable from application of these control options is summarized in Table 4. Photographs of several of the largest flares are presented in Figure 1 to Figure 4.

The baseline market value of the listed commodities present in the flared gas streams is approximately \$16.1 million USD annually. The baseline GHG emission from flaring this gas amounts to almost 164.7 kt/y of CO₂E. The proposed cost-effective control options have payback periods ranging from 0.3 to 5.7 years (see Table 3). Implementing these control options, would greatly reduce the flared hydrocarbon losses. It would also reduce lifetime GHG emissions by 69.9 percent and emissions of other pollutants by 67.0 percent for VOCs, 70.8 percent for CO, - 3.5 percent for NO_x, 93.8 percent for SO₂, and 72.5 percent for PM (determined from Table 4 and the lifetime emissions in the absence of any control technologies).

At all the surveyed oil batteries, except the CCAC.4, the associated gas production is flared due to a lack of economic access to a gas gathering system and inadequate need for use of the gas as fuel. These facilities also had minimal electrical power needs. In these cases, the most practicable control option is to recover the condensable hydrocarbons and flare the residue gas that is in excess of onsite fuel needs. No information was available on the distances to nearby gathering systems, so conservation schemes involving the use of nearby gas-gathering systems were not considered.

At CCAC.4 Oil Battery, the associated gas is conserved and only the solution gas from the storage tanks is flared. In this case, the most practicable option is to compress the solution gas into the gas gathering system.

Flare CCAC.7.9 at the CCAC.7 Compressor Station is an emergency flare pit used to dispose of NGLs during upset conditions. Two flows are reported for this flare: one is the gas consumption by the flare pilot and the other is the combined flow of purge gas and gas leakage into the flare system. The amount of pilot gas consumption is large and could be dramatically reduced by switching to the use low-consumption pilots and/or automating the flare to only ignite during periods of positive flow in the flare header. The amount of pilot gas consumption by the other flares at the site was not measured but may also offer noteworthy opportunities for improvement.

Flare CCAC.7.9 also uses significant amounts of purge gas. This purge gas consumption could be optimized by installing a purge gas reduction seal or potentially eliminating the use of purge gas and only igniting the flare when positive flow reaches the flare tip. Further analysis of this is warranted. A formal program for managing leakage into the flare line is also warranted.

At CCAC.2 the flow to CCAC.2.4 is attributed to inadequate compression to boost all the gas from the inlet separator to the operating pressure of the gas gathering system. The gas flow to Flare CCAC.2.3 is stabilizer overheads and is attributed to inadequate compression to boost all this gas to the inlet pressure of the onsite liquids recovery plant.

Table 1: Baseline commodity losses associated with flaring at the surveyed Pemex facilities.											
Facility	Source	Tag No.	Service/Activity	Value of Commodity Losses (USD/y)		Total Commodity Loss (m ³ /h)	Residue Gas (10 ³ m ³ /d)	Ethane (m ³ /d liq)	LPG (m ³ /d liq)	C ₅ + (m ³ /d)	Hydrogen (m ³ /d)
				Natural Gas Pricing	Commodity Pricing						
CCAC.3 Oil Battery	Flare Stack (Unassisted)	CB-CCAC.3	Associated Gas Disposal	1,247,781	2,741,963	1,299.89	15.40	14.71	15.91	1.04	0.00
CCAC.7 Compressor Station	Flare Pit	CCAC.7.9	Hydrocarbon Liquids Flare	618,745	711,533	787.57	13.44	6.10	1.06	0.01	0.00
CCAC.2	Flare Stack (Air Assist)	CCAC.2.3	Stabilizer Overheads Disposal	62,829	139,824	51.09	0.73	0.80	0.71	0.15	0.00
	Flare Stack (Unassisted)	CCAC.2.4	Continuous Waste Gas Disposal	721,375	2,193,946	432.26	3.23	8.30	16.91	0.18	0.00
CCAC.6 Oil Battery	Flare Stack (Unassisted)	CB-CCAC.6	Associated Gas Disposal	3,169,706	7,717,555	2,269.82	23.78	53.75	50.67	1.42	0.00
CCAC.1 Oil Battery	Flare Stack (Unassisted)	CB-Hidalgo	Associated Gas Disposal	0	0	0.00	0.00	0.00	0.00	0.00	0.00
CCAC.5 Oil Battery	Flare Stack (Unassisted)	CB-CCAC.5	Associated Gas Disposal	1,004,299	1,500,928	1,080.90	21.44	4.85	5.28	0.41	0.00
CCAC.4 Oil Battery	Flare Stack (Unassisted)	CCAC.4.6	Solution Gas Disposal	586,683	1,048,216	614.86	10.26	4.53	3.75	1.39	0.00
Total				7,417,148	16,065,734	6,542.69	88.36	93.09	94.34	4.60	0.00

Table 2: Baseline annual atmospheric emissions of CH₄, CO₂, N₂O CO₂E, VOC, CO, NO_x, SO₂ and PM due to flaring at the surveyed Pemex facilities.

Facility	Source	Tag No.	Service	CH ₄ (t/y)	CO ₂ (t/y)	N ₂ O (t/y)	CO ₂ E (t/y)	VOC (t/y)	CO (t/y)	NO _x (t/y)	SO ₂ (t/y)	PM (t/y)
CCAC.3 Battery	Oil Flare Stack (Unassisted)	CB- CCAC.3	Associated Gas Disposal	76.3	31,006	0.0	32,623	10.7	76.5	14.0	0.0	27.4
CCAC.7 Compressor Station	Flare Pit	CCAC.7.9	Hydrocarbon Liquids Flare	66.6	12,101	0.0	13,506	5.3	37.9	7.0	16.7	13.6
CCAC.2	Flare Stack (Air Assist)	CCAC.2.3	Stabilizer Overheads Disposal	3.6	1,327	0.0	1,403	0.5	3.9	0.7	0.0	1.4
	Flare Stack (Unassisted)	CCAC.2.4	Continuous Waste Gas Disposal	4.0	15,722	0.0	15,815	6.2	44.2	8.1	489.9	15.8
CCAC.6 Battery	Oil Flare Stack (Unassisted)	CB- CCAC.6	Associated Gas Disposal	117.8	67,567	0.1	70,077	27.2	194.4	35.7	1,146.4	69.6
CCAC.1 Battery	Oil Flare Stack (Unassisted)	CB- Hidalgo	Associated Gas Disposal	0.0	0	0.0	0	0.0	0.0	0.0	0.0	0.0
CCAC.5 Battery	Oil Flare Stack (Unassisted)	CB- CCAC.5	Associated Gas Disposal	106.2	20,926	0.0	23,167	8.6	61.6	11.3	27.4	22.1
CCAC.4 Battery	Oil Flare Stack (Unassisted)	CCAC.4.6	Solution Gas Disposal	50.8	12,820	0.0	13,894	5.0	36.0	6.6	0.0	12.9
Total				425.7	161,608.5	0.3	170,632.2	63.7	454.8	83.5	1,681.0	162.9

Table 3: Lifetime economic analysis of applying the most promising cost-effective control technology to the flares at each surveyed Pemex facility.

Facility	Source	Tag No.	Control Technology	Application Life Expectancy (y)	Capital Cost (USD)	Net Present Salvage Value (USD)	Net Operating Cost (USD/y)	Baseline Value of Conserved Energy (USD/y)	NPV (USD)	ROI (%)	Payback Period (y)
CCAC.3 Oil Battery	Flare Stack (Unassisted)	CB-CCAC.3	Recover Condensable Hydrocarbons & Flare Excess Residue Gas	10	---	---	---	---	---	---	---
CCAC.7 Compressor Station	Flare Pit	CCAC.7.9	Pilot Gas Optimization	20	\$180,000	\$0	\$0	\$135,191	\$970,960	75.11%	1.3
			Purge Gas Optimization	20	\$2,692,800	\$0	\$69,891	\$540,765	\$1,316,019	17.49%	5.7
CCAC.2	Flare Stack (Air Assist)	CCAC.2.3	Return To Plant Inlet	20	\$534,000	\$0	\$21,978	\$2,084,249	\$17,023,268	386.19%	0.3
	Flare Stack (Unassisted)	CCAC.2.4	Recover Condensable Hydrocarbons & Conserve Residue Gas	20	\$1,062,153	\$0	\$61,940	\$3,011,220	\$24,046,736	277.67%	0.4
CCAC.6 Oil Battery	Flare Stack (Unassisted)	CB-CCAC.6	Recover Condensable Hydrocarbons & Flare Excess Residue Gas	10	---	---	---	---	---	---	---
CCAC.1 Oil	Flare Stack	CB-	Recover	10	---	---	---	---	---	---	---

Table 3: Lifetime economic analysis of applying the most promising cost-effective control technology to the flares at each surveyed Pemex facility.

Facility	Source	Tag No.	Control Technology	Application Life Expectancy (y)	Capital Cost (USD)	Net Present Salvage Value (USD)	Net Operating Cost (USD/y)	Baseline Value of Conserved Energy (USD/y)	NPV (USD)	ROI (%)	Payback Period (y)
Battery	(Unassisted)	Hidalgo	Condensable Hydrocarbons & Flare Excess Residue Gas								
CCAC.5 Oil Battery	Flare Stack (Unassisted)	CB-CCAC.5	Recover Condensable Hydrocarbons & Flare Excess Residue Gas	10	---	---	---	---	---	---	---
CCAC.4 Oil Battery	Flare Stack (Unassisted)	CCAC.4.6	Inject Into Gathering System	10	\$8,346	\$0	\$0	\$5,862	\$11,986	35.91%	1.7
Total					\$4,477,299	\$0	\$153,809	\$5,777,288	\$43,368,969	---	---

1. NPV denotes net present value.
2. ROI denotes return on investment.

Table 4: Lifetime atmospheric emission reductions due to application of the most promising cost effective control options to the flares at the surveyed Pemex facilities.

Facility	Source	Tag No.	Control Technology	CH ₄ (t)	CO ₂ (t)	N ₂ O (t)	CO ₂ E (t)	VOC (t)	CO (t)	NO _x (t)	SO ₂ (t)	PM (t)
CCAC.3 Oil Battery	Flare Stack (Unassisted)	CB-CCAC.3	Recover Condensable Hydrocarbons & Flare Excess Residue Gas	---	---	---	---	---	---	---	---	---
CCAC.7 Compressor Station	Flare Pit	CCAC.7.9	Pilot Gas Optimization	253.0	45,982	0.1	51,322	20.2	144.2	26.5	63.3	51.7
			Purge Gas Optimization	1,011.8	171,385	0.3	192,718	80.8	576.7	105.8	253.2	206.6
CCAC.2	Flare Stack (Air Assist)	CCAC.2.3	Return To Plant Inlet	-15.8	290,364	-0.5	289,886	109.1	799.5	92.2	9,308.4	301.1
	Flare Stack (Unassisted)	CCAC.2.4	Recover Condensable Hydrocarbons & Conserve Residue Gas	1,981.2	1,260,348	-0.5	1,301,791	493.2	3,627.8	-159.7	21,781.8	1,322.9
CCAC.6 Oil Battery	Flare Stack (Unassisted)	CB-CCAC.6	Recover Condensable Hydrocarbons & Flare Excess Residue Gas	---	---	---	---	---	---	---	---	---
CCAC.1 Oil	Flare Stack	CB-	Recover	---	---	---	---	---	---	---	---	---

Table 4: Lifetime atmospheric emission reductions due to application of the most promising cost effective control options to the flares at the surveyed Pemex facilities.

Facility	Source	Tag No.	Control Technology	CH ₄ (t)	CO ₂ (t)	N ₂ O (t)	CO ₂ E (t)	VOC (t)	CO (t)	NO _x (t)	SO ₂ (t)	PM (t)
Battery	(Unassisted)	Hidalgo	Condensable Hydrocarbons & Flare Excess Residue Gas									
CCAC.5 Oil Battery	Flare Stack (Unassisted)	CB-CCAC.5	Recover Condensable Hydrocarbons & Flare Excess Residue Gas	---	---	---	---	---	---	---	---	---
CCAC.4 Oil Battery	Flare Stack (Unassisted)	CCAC.4.6	Inject Into Gathering System	0.0	162	0.0	162	0.1	0.4	0.1	0.0	0.2
Total				3,230.3	1,768,240.4	-0.6	1,835,879.4	703.4	5,148.5	64.9	31,406.7	1,882.4



Figure 1: Photographs, from left to right, of Flares CCAC.2.2, CCAC.2.3 and CCAC.2.4 at the CCAC.2 Oil Terminal, 29 to 30 September 2014.



Figure 2: Photograph of the flare at the CCAC.3 Oil Battery, 8 October 2014.



Figure 3: Photograph of Flare CCAC.7.19 at the CCAC.7 Compressor Station, 2, October 2014.



Figure 4: Photographs of Flare CCAC.7.9 at the CCAC.7 Compressor Station, 2 October 2014.

2.2 STORAGE LOSSES

The baseline hydrocarbon losses, by commodity type, associated with the venting of solution gas from the crude oil production tanks at the surveyed oil batteries are summarized in Table 5. Table 6 presents the estimated baseline atmospheric emissions due to this solution gas venting. The detailed results and assessment methodology are presented in Appendix 9 (Storage Losses).

Table 7 presents the lifetime economic analysis results for application of only the most promising cost-effective control options. Entries of “---“ indicate that either no cost-effective control options were identified for the given source or there was negligible gas flow to the given flare. The lifetime emission reductions reasonably achievable from application of these control options is summarized in Table 8.

The baseline market value of the listed commodities present in the vented gas streams is approximately 0.02 million USD annually. The baseline GHG emission from venting this gas amounts to almost 0.8 kt/y of CO₂E. None of the identified vapour control opportunities had cost-effective control options due to the current low energy prices (see Table 7).

The crude oil production tanks at all but CCAC.4 Oil Battery were vented to the atmosphere. The tanks at CCAC.4 Oil Battery were connected to a low pressure flare system and are addressed in Section 2.1. The amount of emission from these tanks and vapour composition were determined by rigorous process simulations. Table 5 summarizes the baseline commodity loss associated with this venting. Table 6 gives the estimated baseline atmospheric emissions from these sources, while Table 7 presents the lifetime economic analysis results for all cost-effective vapour recovery options. In each case, it is assumed that the collected vapours are commingled with, and handled in the same manner as, the associated gas production. Entries of “---“ indicate that no cost-effective vapour control options were identified.

Table 5: Baseline commodity losses associated with venting of solution gas from production storage tanks at the surveyed Pemex oil batteries.											
Facility	Source Type	Tag No.	Service	Value of Commodity Losses (USD/y)		Total Commodity Loss (m ³ /h)	Residue Gas (10 ³ m ³ /d)	Ethane (m ³ /d liq)	LPG (m ³ /d liq)	C ₅ + (m ³ /d)	Hydrogen (m ³ /d)
				Natural Gas Pricing	Commodity Pricing						
CCAC.3 Oil Battery	Fixed Roof	TV-CCAC.3	Crude Oil	3,440	7,559	3.58	0.04	0.04	0.04	0.00	0.00
CCAC.6 Oil Battery	Fixed Roof	TV-CCAC.6	Crude Oil	657	1,716	0.67	0.01	0.01	0.01	0.00	0.00
CCAC.1 Oil Battery	Fixed Roof	TV-Hidalgo	Crude Oil	1,161	1,736	1.25	0.02	0.01	0.01	0.00	0.00
CCAC.5 Oil Battery	Fixed Roof	TV-CCAC.5	Crude Oil	4,214	7,530	4.42	0.07	0.03	0.03	0.01	0.00
CCAC.4 Oil Battery	Fixed Roof	TV-PozRicIX	Crude Oil	---	---	---	---	---	---	---	---
Total				9,472	18,539	9.92	0.15	0.09	0.09	0.02	0.00

Table 6: Baseline annual atmospheric emissions due to venting of solution gas from production storage tanks at the surveyed Pemex oil batteries.												
Facility	Source Type	Tag No.	Service	CH₄ (t/y)	CO₂ (t/y)	N₂O (t/y)	CO₂E (t/y)	VOC (t/y)	CO (t/y)	NO_x (t/y)	SO₂ (t/y)	PM (t/y)
CCAC.3 Oil Battery	Fixed Roof	TV-CCAC.3	Crude Oil	10.5	14	0.0	234	9.2	0.0	0.0	0.0	0.0
CCAC.6 Oil Battery	Fixed Roof	TV-CCAC.6	Crude Oil	1.6	3	0.0	35	2.4	0.0	0.0	0.0	0.0
CCAC.1 Oil Battery	Fixed Roof	TV-Hidalgo	Crude Oil	6.1	1	0.0	130	1.3	0.0	0.0	0.0	0.0
CCAC.5 Oil Battery	Fixed Roof	TV-CCAC.5	Crude Oil	18.3	6	0.0	390	7.6	0.0	0.0	0.0	0.0
CCAC.4 Oil Battery	Fixed Roof	TV-PozRicIX	Crude Oil	---	---	---	---	---	---	---	---	---
Total				36.5	24.0	0.0	789.7	20.5	0.0	0.0	0.0	0.0

Table 7: Lifetime economic analysis of recovering the vapours from the production storage tanks at the surveyed Pemex oil batteries and commingling it with the associated gas for processing using the associated gas control technology.

Facility	Source Type	Tag No.	Control Technology	Application Life Expectancy (y)	Capital Cost (USD)	Net Present Salvage Value (USD)	Net Operating Cost (USD/y)	Baseline Value of Conserved Energy (USD/y)	NPV (USD)	ROI (%)	Payback Period (y)
CCAC.3 Oil Battery	Fixed Roof	TV-CCAC.3	Vapour Recovery	10	---	---	---	---	---	---	--
CCAC.6 Oil Battery	Fixed Roof	TV-CCAC.6	Vapour Recovery	10	---	---	---	---	---	---	--
CCAC.1 Oil Battery	Fixed Roof	TV-Hidalgo	Vapour Recovery	10	---	---	---	---	---	---	--
CCAC.5 Oil Battery	Fixed Roof	TV-CCAC.5	Vapour Recovery	10	---	---	---	---	---	---	--
CCAC.4 Oil Battery	Fixed Roof	TV-PozRicIX	Vapour Recovery	10	---	---	---	---	---	---	--
Total				---	---	---	---	---	---	---	--

1. NPV denotes net present value.
2. ROI denotes return on investment.

Table 8: Lifetime reduction in atmospheric emissions due to application of all cost-effective vapour recovery applications.¹												
Facility	Source Type	Tag No.	Control Technology	CH₄ (t)	CO₂ (t)	N₂O (t)	CO₂E (t)	VOC (t)	CO (t)	NO_x (t)	SO₂ (t)	PM (t)
CCAC.3 Oil Battery	Fixed Roof	TV-CCAC.3	Vapour Recovery	---	---	---	---	---	---	---	---	---
CCAC.6 Oil Battery	Fixed Roof	TV-CCAC.6	Vapour Recovery	---	---	---	---	---	---	---	---	---
CCAC.1 Oil Battery	Fixed Roof	TV-Hidalgo	Vapour Recovery	---	---	---	---	---	---	---	---	---
CCAC.5 Oil Battery	Fixed Roof	TV-CCAC.5	Vapour Recovery	---	---	---	---	---	---	---	---	---
CCAC.4 Oil Battery	Fixed Roof	TV-PozRicIX	Vapour Recovery	---	---	---	---	---	---	---	---	---
Total				---	---	---	---	---	---	---	---	---

¹A negative reduction in a GHG or CAC indicates an increase in emissions from combusting the non-recovered portion of the vented gas.

3 CONCLUSIONS AND RECOMMENDATIONS

3.1 CONCLUSIONS

A targeted measurement program conducted at five oil batteries, and a major oil terminal and gas gathering compressor station show there are noteworthy practicable opportunities to reduce venting and flaring at Pemex facilities. Those at production facilities may have significant replicability.

Opportunities for gross savings of \$16.1 million USD/y and emission reductions of 171.4 kt CO₂E/y were assessed at the surveyed facilities. It is estimated that applying the most practicable control options having a positive payback period would result in a 77.8 percent reduction in GHG emissions. The results for the oil batteries have not been extrapolated across all facilities (i.e., due to a lack of a total count of equivalent facilities); doing so would result in increased values.

3.2 RECOMMENDATIONS

It is recommended that a more refined analysis be conducted of the most promising flare and vent gas reduction opportunities addressed herein and that consideration be given to an extended measurement program to identify other noteworthy opportunities.

4 REFERENCES CITED

None.

5 APPENDIX - GLOSSARY

Term	Definition
Abandoned Well	A well that has been drilled, abandoned, cut, and capped at the surface.
Abandonment	The permanent dismantlement of a facility so that it is permanently incapable of its original intended use. This includes leaving downhole or subsurface structures in a permanently safe and stable condition; the removal of associated equipment and structures; the removal of all produced liquids; and the removal and appropriate disposal of structural concrete.
Accidental Releases	Unintentional releases of oil, produced water, process chemicals and/or natural gas to the environment by human error, equipment malfunction, or a major equipment failure (e.g., pipeline break, well blow out, explosion, etc.).
Acid Gas	A gaseous mixture that is separated in the treating of solution, associated or non-associated natural gas and which typically contains hydrogen sulphide (H ₂ S), total reduced sulphur compounds, and/or carbon dioxide (CO ₂).
Acid Gas Injection Facility	Facility constructed and operated for the purpose of moving acid gas (a mixture containing hydrogen sulphide (H ₂ S), total reduced sulphur compounds, and/or carbon dioxide (CO ₂) that is separated in the treating of solution, associated or non-associated natural gas) into a petroleum reservoir or other porous and permeable geologic formation.
Acid Precipitation	<p>Acid precipitation (or acid rain) results from the atmospheric emission of oxides of sulphur (SO_x) and oxides of nitrogen (NO_x). Both types of pollutants are products of combustion. In the air, these substances react with atmospheric moisture to produce sulphuric (H₂SO₄) and nitric (HNO₃) acid, respectively. Eventually, these substances are carried to earth by precipitation (rain or snow).</p> <p>The precursors of acid rain may produce respiratory and other internal disease when inhaled in high concentrations. Also, acid rain has potentially serious indirect effects on human health. The two major concerns regarding indirect health effects are: (1) the leaching of toxic chemicals by acidified waters leading to contamination of drinking water supplies, and (2) the contamination of edible fish by toxic chemicals, principally mercury. Acid rain has also been known to damage aquatic ecosystems (National Research Council, 1981).</p>
Air Toxics	These are air pollutants that are either known or believed to have an adverse effect on human health. For many such compounds 15-minute, 1-hour and 8-hour occupational exposure limits have been established but acceptable limits for prolonged low-concentration exposure are uncertain
Ancillary Equipment	Any of the following pieces of equipment: pumps, pressure relief devices, sampling connection systems, open-ended valves, or lines, valves, flanges, or other connectors.

Term	Definition
API Gravity	The weight per unit volume of hydrocarbon liquids as measured by a system recommended by the American Petroleum Institute (API). The measuring scale is calibrated in terms of degrees API. API Gravity is the industry standard for expressing the specific gravity of crude oils. A high API gravity means lower specific gravity and lighter oils.
API Separator	A gravity-type oil-water separator, such as those described in American Petroleum Institute (API) Publication No. 421. These separators are used for primary treatment of oily water discharged from process sewer systems. Typically, the separator comprises one or more open channels in parallel. Each channel is equipped with a surface oil skimmer and a sludge collection system.
Associated Natural Gas	Natural gas that is produced in conjunction with crude oil, including bitumen.
Atmospheric Distillation	The atmospheric distillation unit (ADU) separates most of the lighter end products such as gas, gasoline, naphtha, kerosene, and gas oil from desalted crude oil which has been preheated to temperatures ranging from 650° to 700° F (above these temperatures undesirable thermal cracking may occur). The crude is fed into the vertical distillation column just above the bottom, at pressures slightly above atmospheric. All but the heaviest fractions flash into vapour. As the hot vapor rises in the tower, its temperature is reduced. Heavy fuel oil or asphalt residue is taken from the bottom. At successively higher points on the tower, the various major products including lubricating oil, heating oil, kerosene, gasoline, and uncondensed gases (which condense at lower temperatures) are drawn off. The bottoms of the ADU are sent to the vacuum distillation unit (VDU).
Bitumen	A naturally occurring viscous mixture consisting of hydrocarbons heavier than pentane and other contaminants, such as sulphur compounds, which in its natural state will not flow under reservoir conditions or on the surface. Bitumen occupies the lower end of the range of heavy crude oils and is sometimes referred to as ultra-heavy crude oil.
Black Carbon	<p>This is emitted directly into the atmosphere in the form of fine particles (PM_{2.5}). It is the most strongly light-absorbing component of soot and is formed by the incomplete combustion of fossil fuels, biofuels, and biomass.</p> <p>Per unit of mass in the atmosphere, BC can absorb a million times more energy than carbon dioxide (CO₂).</p>
Black Oil	A hydrocarbon (petroleum) liquid with an initial producing gas-to-oil ratio (GOR) less than 0.31 cubic meters per liter and an API gravity less than 40 degrees.
Blanket Gas	Storage tanks are equipped with gas blanket systems to reduce vapour emissions (especially when the vapours are sour) and to ensure that oxygen does not enter the vapour space of the tank when it is connected to a flare system or vapour recovery unit. The blanket gas is usually fuel gas but any other inert gas could be used.

Term	Definition
	Storage tanks with gas blanket systems are usually connected to a flare or vapour recovery system, but in some cases (if the gas is not sour) the tank vapours and blanket gas may be released untreated to the atmosphere through a vent system.
Block Valve Station	A block valve used to isolate a segment of the main pipeline for tie-in or maintenance purposes. On gas transmission systems, block valves are typically located at distances of 25 to 80 km along each line to limit the amount of piping that may need to be depressurized for tie-ins and maintenance, and to reduce the amount of gas that would be lost in the event of a line break.
Blowdown Treatments	Some natural gas wells must be blown down periodically to remove water that has accumulated in the production tubing. These are primarily shallow (less than 1000 m deep), low-pressure (less than 2000 kPa) gas wells. Shallow gas wells are typically sweet and usually are not equipped with flares. Thus, the natural gas that is discharged during blowdown operations is vented to the atmosphere unburned.
Blowout	The complete loss of control of the flow of fluids from a well to the atmosphere or the flow of fluids from one underground reservoir to another (an underground blowout). Wellbore fluids are released uncontrolled at or near the wellbore. Well control can only be regained by installing or replacing equipment to shut in or kill the well or by drilling a relief well.
Boiler	An enclosed device using controlled flame combustion and having the primary purpose of recovering and exporting thermal energy in the form of steam or hot water.
Booster Station	A facility where gas pressure is increased to overcome friction losses through a pipeline. Centrifugal or axial-flow compressors are most commonly used in these applications. A station typically comprises several units in series or parallel, as well as the necessary suction and discharge piping. Many booster stations also have discharge coolers to reduce the viscosity of the compressed gas and thereby increase the efficiency of gas transmission.
Border Meter Station	A meter station where custody of the natural gas is transferred from one gas transmission system to another at a provincial/state or national boundary. These stations are usually larger than normal meter stations. Typically, they have 10 to 20 large diameter meter runs (16 to 20 NPS lines) and no pressure regulation.
CAS Number	Chemical Abstracts Number. A unique number that identifies a chemical substance.
Casinghead Gas	<p>Dissolved natural gas and associated natural gas may be produced concurrently from the same well bore. In such situations, it is not feasible to measure the production of dissolved gas and associated gas separately; therefore, production is reported as casinghead gas. Sometime it may simply be referred to as either associated gas or solution gas.</p> <p>Typically casinghead gas is vented to the atmosphere when the wellhead pressure drops below gas sales line pressure.</p>
Central Crude Oil Treating Plant	Battery system or arrangements of tanks or other surface equipment without any directly associated wells.

Term	Definition
Centrifugal Compressor Seal Systems	Centrifugal compressors generally require shaft-end seals between the compressor and bearing housings. Either face-contact oil-lubricated mechanical seals or oil-ring shaft seals, or dry-gas shaft seals are used. The amount of leakage from a given seal will tend to increase with wear between the seal and compressor shaft, operating pressure and rotational speed of the shaft.
Choked Flow	This occurs where the local fluid velocity is equal to the speed of sound in that fluid at its flowing temperature and pressure. Under these conditions the fluid flow is too fast for decompression waves to travel upstream. Consequently, there is no longer any driving force for further increases in the flow rate and the flow is therefore choked.
Closed-Vent System	A system that is not open to the atmosphere and is composed of piping, ductwork, connections, and, if necessary, flow inducing devices that transport gas or vapour from an emission point to one or more control devices.
CO Boiler	A boiler to combust carbon monoxide and other coker off-gas, thereby recovering excess energy and reducing the emission of potential pollutants.
Coke	See petroleum coke.
Coker	A thermal processing unit which cracks heavy petroleum streams, such as heavy oil, bitumen, and vacuum still bottoms into light products while reducing much of that feedstock to solid carbon. The liquids yielded by these units, often called coker naphtha and coker gasoil, usually pass through upgrading equipment on the way to finished fuels and synthetic crude oil production.
Coker (Delayed)	<p>A type of coker that involves heating heavier hydrocarbon feedstock to its thermal cracking temperature (e.g., to nearly 540°C) in a multi parallel pass furnace. This initiates the cracking of the long chain heavy hydrocarbon molecules in the coker feed. In the coke drum, light hydrocarbon fractions vaporize and separate from coke. The vapour is directed to a fractionation column where it is separated into the desirable boiling point fractions. The liquid coke solidifies in the drum as it cools.</p> <p>After the drum is full of the solidified coke, the hot mixture from the furnace is switched to a second drum. While the second drum is filling, the full drum is steamed to further reduce hydrocarbon content of the petroleum coke, and then is water quenched to cool it. The top and bottom heads of the full coke drum are removed, and the solid petroleum coke is then cut from the coke drum with high-pressure water nozzles, where it falls into a pit for subsequent disposition (e.g., to storage, fuel use or sales).</p>
Coker (Flexi)	The flexicoker adds a third vessel, a gasifier, to the fluid coker to gasify the purge coke into a weak fuel gas. Coke is made in 3 areas: purge coke from the heater, and both larger and smaller recovered coke fines from the weak gas scrubbers. It is a “flexible” coker in that the gasifier can be run to make either more coke or more weak fuel gas.
Coker (Fluid)	A fluid coker is a carbon rejection process which thermally cracks bitumen into low boiling

Term	Definition
	range, higher carbon-to-hydrogen ratio gas and liquid products, and to very low hydrogen-to-carbon ratio coke. The process comprises a continuous fluidized bed consisting of a reactor and a burner vessel utilizing coke transfer lines. Hot bitumen feed is sprayed onto seed pellets of coke in the reactor where thermal cracking occurs. Coke product is drawn off the burner vessel and stored on-site for future potential commercial use.
Coking	A refining and upgrading carbon-rejection process in which heavy hydrocarbon feedstock (e.g., heavy oil, crude bitumen or the heavy residuals from the distillation process) are converted to lighter products such as fuel gas, gas oil, naphtha and petroleum coke. There are 3 types of cokers: delayed, fluid, and flexi (see each).
Cold Recovery	The production of crude oil which does not involve the use of any thermal techniques.
Combustion Device	An individual unit of equipment, such as a flare, incinerator, process heater, or boiler, used for the combustion of organic emissions.
Combustion Efficiency	This is the extent to which all input combustible material has been completely oxidized (i.e., to produce H ₂ O, CO ₂ and SO ₂). Complete combustion is often approached but is never truly achieved. The main factors that contribute to incomplete combustion include thermodynamic, kinetic, mass transfer and heat transfer limitations. In fuel rich systems, oxygen deficiency is also a factor.
Compressed Natural Gas (CNG)	Natural gas compressed into high-pressure fuel cylinders to power a car or truck. It comes from special CNG fuel stations.
Compressor Start Gas	Most gas-fired compressors use a gas-operated motor for starting. Typically the supply gas is natural gas but in some cases compressed air may be used. During a start the gas passes through the start motor and is vented to the atmosphere. Start volumes are rarely measured and are most often estimated based on the number of starts and their duration or simply the number of starts.
Compressor Station (Booster)	Service equipment intended to maintain or increase the flowing pressure of the gas that it receives from a well, battery, or gathering system prior to delivery to market or other disposition.
Compressor Station (Feed)	A facility where gas pressure is increased to allow the gas to enter into a higher pressure pipeline system (i.e., feed rather than booster service). Both centrifugal and reciprocating compressor units may be used in these applications. However, use of reciprocating compressors is most common. A station typically comprises several units in series or parallel, as well as the necessary suction and discharge piping. Many compressors also have discharge coolers to reduce the viscosity of the compressed gas and thereby increase the efficiency of gas transmission.
Condensate	Hydrocarbon liquid separated from natural gas that condenses due to changes in the temperature, pressure, or both, that remains liquid at standard reference conditions.
Condensate Storage	A facility for storage of hydrocarbon condensate (usually in aboveground atmospheric storage tanks featuring floating roofs or a gas blanketing and vapour recovery system).
Connectors	Any flanged or threaded connection, or mechanical coupling, but excluding all welded or back-welded connections. If properly installed and maintained, a connector can provide essentially

Term	Definition
	leak-free service for extended periods of time. However, there are many factors that can cause leakage problems to arise. Some of the common causes include vibration, thermal stress and cycles, dirty or damaged contact surfaces, incorrect sealing material, improper tightening, misalignment, and external abuse.
Control Device	Any equipment used for recovering or oxidizing waste natural gas or VOC vapours. Such equipment includes, but is not limited to, absorbers, carbon adsorbers, condensers, incinerators, flares, boilers, and process heaters.
Control Valve Station	A modulating valve that controls either the flow rate or pressure through the pipeline. In the latter case, this facility is often referred to as a regulator station. Usually, high-pressure gas from the pipeline is used as the supply medium needed to energize the valve actuator.
Conventional Crude Oil	Crude oil obtained via “conventional” recovery methods (i.e., normal primary, secondary or tertiary processes) from a “conventional” source (i.e., not from bituminous sands, shales or carbonates) in a “conventional” location (i.e., not from the frontier, including the offshore).
Conventional Natural Gas	Natural gas obtained via “conventional” recovery methods (i.e., normal primary, secondary or tertiary processes) from a “conventional” source (i.e., not from coalbeds or tight reservoir formations) in a “conventional” location (i.e., not from the frontier, including the offshore).
Cracking	A thermal or catalytic process for breaking down larger, heavier and more complex hydrocarbons into simpler, lighter products, and potentially coke, to produce a variety of fuel products.
Criteria Air Pollutants	These are pollutants for which ambient air quality objectives have been promulgated. These typically include SO ₂ , NO _x , particulate matter (PM), and CO. Additionally, volatile organic compounds (VOCs) also may be a criteria air pollutant in some jurisdictions.
Crude Bitumen	A term used by the Government of Alberta to designate any non-coal, non-natural gas hydrocarbon produced from a designated oil sands area.
Crude Oil	A mixture of hydrocarbons that exist in the liquid phase in natural underground reservoirs and remains liquid at atmospheric pressure and temperature after passing through surface separation facilities.
Crude Oil Battery	A system or arrangement of tanks or other surface equipment receiving primarily oil or bitumen from one or more wells prior to delivery to market or other disposition. An oil battery may include equipment for measurement, for separating inlet streams into oil, gas, and/or water phases, for cleaning and treating the oil, for disposal of the water, and for conservation of the produced gas. A tank battery may or may not include a glycol dehydration unit and compressor.
Crude Oil Group Battery	Crude oil production facility consisting of two or more flow-lined oil wells having individual separation and measurement equipment but with all equipment sharing a common surface location.
Crude Oil Losses	The volume of crude oil (including lease condensate) reported by petroleum refineries, pipelines and lease holders as being lost or unaccounted for in their operations. These losses are of a non-

Term	Definition
	processing nature (i.e., losses due to spills, contamination, fires, etc.), as opposed to refinery processing losses or gains.
Crude Oil Proration (or Fieldgate) Battery	A production facility consisting of two or more flow-lined oil wells having common separation and measuring equipment. Total production is prorated to each well based on individual well tests. Individual well production tests can occur at the central site or at remote satellite facilities.
Crude Oil Satellite Battery	A small group of surface equipment (not including storage tanks) located between a number of wells and the main crude oil battery that is intended to separate and measure the production from each well, after which the fluids are recombined and piped to the main crude oil battery for treating and storage or delivery.
Crude Oil Single Battery	Crude oil production facility for a single oil well or a single zone of a multiple completion crude oil well.
Custody Transfer Point	The transfer of hydrocarbon liquids or natural gas: after processing and/or treatment in the producing operations, or from storage vessels or automatic transfer facilities or other such equipment, including product loading racks, to pipelines or any other forms of transportation.
Custom Treating Plant	System or arrangement of tanks and other surface equipment receiving crude oil/water emulsion exclusively by truck for separation prior to delivery to market or other disposition.
Cyclical Well	A crude bitumen well requiring steam to be injected to produce the hydrocarbons. The steaming and producing are performed in alternating cycles.
Deasphalting	A family of processes that use light solvents to selectively reject highly aromatic or 'asphaltenic' fractions.
Deep Natural Gas Well	A gas well greater than 1000 m deep. These wells are typically high-pressure and may be sweet or sour.
Dehydrator	A device used to remove water and water vapors from gas. Gas dehydration can be accomplished through a glycol dehydrator or a dry-bed dehydrator, which use a liquid desiccant and a solid desiccant, respectively.
Desalter	A desalter is a process unit at an oil refinery or upgrader that removes salt from the crude oil. It is usually the first process. The desalter mixes the hydrocarbon stream with a small amount of fresh water (e.g. 10% by volume) forming a water-in-oil emulsion. The salt dissolves in the water. The resulting emulsion is subjected to an electric field wherein the water is coalesced as an under flow from the upper flow of a relatively water-free, continuous hydrocarbon phase.
Destruction Efficiency	The extent to which a target substance present in the input combustibles has been destroyed (i.e., converted to intermediate, partially-oxidized and fully-oxidized products of combustion).
Development Well	A well drilled within the proved area of an oil or gas reservoir to the depth of a stratigraphic horizon known to be productive. If the well is completed for production, it is classified as an oil or gas development well. If the well is not completed for production, it is classified as a dry development hole.

Term	Definition
Diesel Fuel	A general term covering light fuel oil derived from gas oil used in diesel engines.
Diluent	Light petroleum liquids used to dilute heavy crude oil, particularly bitumen, so that it can flow more easily through pipelines.
Direct-Fired Heater	The combustion gases occupy most of the heater volume and heat the process stream contained in pipes arranged in front of refractory walls (the radiant section) and in a bundle in the upper portion (the convective section). Convective heaters are a special application in which there is only a convective section.
Disposal Well	A well used for the disposal, into a reservoir or aquifer, of any oilfield or processing waste fluids or produced water.
Dissolved Natural Gas	Natural gas that is in solution with crude oil in the reservoir at reservoir conditions (temperature and pressure).
Dissolved-Air Flotation (DAF) Separator	A gravity-type oil-water separator equipped with a method for introducing compressed air at the bottom of the separator near the inlet to aid the floatation of suspended oil and solid particles (i.e., dissolved air floatation thickening). A DAF separator is generally used in conjunction with an API separator. The API separator removes the gross free hydrocarbon products that readily float while the DAF separator is used to polish the effluent from the API separator.
Distillates	Products of condensation produced during the fractional distillation process (e.g., gaseous fuels, naphtha, kerosene, gas oils and fractions used for the manufacture of base oils (SPO, LMO and MMO)).
Distribution Farm Tap	A small pressure regulating station located in rural or semi-rural areas on high-pressure pipelines flowing odourized gas. It usually only regulates the pressure down to a distribution pressure, and often, does not include metering equipment.
Distribution Mains	Distribution mains deliver odourized gas to the customers. They range in size from: 2 NPS in rural distribution to 24 NPS, with the most common being 2 to 8 NPS. Systems constructed of plastic pipe (mostly polyethylene, but also P.V.C. or some other plastics), typically, are operated at pressures of up to 690 kPag (100 psig), although there are polyethylene resins that allow operation at pressures slightly over 700 kPag (100 psig). Higher pressure steel pipelines (either with or without cathodic protection) flowing odourized gas are typically considered distribution mains.
Distribution Stations	Stations associated with the distribution mains that handle odourized natural gas. By function they include gate stations, district regulating stations, distribution farm taps and industrial meter sets.
District Regulating Stations	A secondary regulating facility located downstream of a gate station on gas distribution systems where gas pressure is further reduced (usually to about 400 kPag [60 psig] but sometimes only to 1200 kPag [175 psig], depending on the company).
Dry Hole	An exploratory or development well determined to be incapable of producing either oil or gas in sufficient quantities to justify completion as an oil or gas well.

Term	Definition
Dry Natural Gas	Field natural gas that does not require any processing to meet contract hydrocarbon dew point requirements.
Emergency Shutdown (ESD) Valve Station	A valve installed on a pipeline, which will automatically close when the line pressure drops below a critical setpoint value. Their purpose is to minimize the amount of gas released in the event of a line break. ESD valve stations are most commonly used on sour natural gas gathering systems.
Emulsion	A combination of two immiscible liquids (i.e., liquids that do not mix together under normal conditions).
Emulsion Treater	See heater-treater.
Enhanced Recovery	The production of crude oil using secondary and/or tertiary recovery techniques.
Equipment Leaks	Emissions of natural gas or hydrocarbon liquids from equipment components (i.e., valves, connectors, compressor seals, pump seals, pressure relief devices, and sampling systems).
Extraction Facility	A facility unique to the oil sands industry that separates the bitumen from the oil sand ore using hot water, steam, caustic soda and potentially other additives.
Extraction Loss (or Shrinkage)	The reduction in volume of natural gas resulting from the removal of the natural gas liquid constituents of natural gas at the processing plant
Field	An area consisting of a single reservoir or multiple reservoirs all grouped on, or related to, the same individual geological structural feature and/or stratigraphic condition. There may be two or more reservoirs in a field that are separated vertically by intervening impervious strata, or laterally by local geologic barriers, or by both.
Field Dehydrator	A dehydration unit located upstream of a natural gas processing plant or natural gas battery to control hydrates rather than provide any final treatment to meet sales specifications.
Field Facility	An installation designed for one or more specific limited functions. Such facilities usually process natural gas produced from more than one lease for the purpose of recovering condensate from the stream of natural gas; however, some field facilities are designed to recover propane, butane, natural gasoline, etc., and to control the quality of the natural gas to be marketed. Field facilities include compressors, dehydration units, field extraction units, scrubbers, drip points, conventional single- or multiple-stage separation units, low-temperature separators, and other types of separation and recovery equipment.
Field Natural Gas	Natural gas extracted from a production well prior to its entering the first stage of processing, such as dehydration.
Filling Losses	Evaporation losses that occur during the filling of tank trucks, tanker rail cars and marine tankers.
Fire-Tube Heaters	The combustion gases are contained in a fire-tube that is surrounded by a liquid that fills the heater shell. This liquid may be either the process stream or a heat medium that surrounds the

Term	Definition
	coil bundle containing the process stream. Common applications are indirect-fired water-bath heaters (line heaters) and glycol reboilers.
Fixed Roof	A cover that is mounted on a storage vessel in a stationary manner and that does not move with fluctuations in liquid level.
Flare	An open flame used for routine or emergency disposal of waste gas. There are a variety of different types of flares including: flare pits, flare stacks, enclosed flares and ground flares. The flare stacks are designed to provide safe atmospheric dispersion of the effluent. Enclosed flares are used to avoid visible flames that may be upsetting to the public. Ground flares are also used to avoid visible flames and may be considered where good atmospheric dispersion of the combustion products is not critical. Flare pits are designed to dispose of waste natural gas streams that may contain significant amounts of hydrocarbon liquids; however, their use is no longer allowed in many jurisdictions due to their potential to contribute to ground water contamination.
Flaring	Flaring is a common method of disposing of waste gas volumes at oil and natural gas facilities. Flares are normally used where the waste gas contains odorous or toxic components (e.g., hydrogen sulphide). Otherwise the gas may be vented. Typically, separate flare/vent systems are used for high- and low-pressure waste gas streams.
Flow Indicator	A device that indicates whether gas flow is present in a line or whether the valve position would allow gas flow to be present in a line.
Flowing Well	A well capable of producing fluids to surface through natural reservoir drive mechanisms, usually formation pressure.
Flue Gas Desulphurization	<p>A flue gas desulfurization system, or scrubber, is a device that removes more than 90 percent of the sulfur dioxide in the flue gases from a combustion process. This is done by a variety of methods:</p> <ul style="list-style-type: none"> • Wet scrubbing using a slurry of sorbent, usually limestone or lime, to scrub the gases. • Spray-dry scrubbing using similar sorbent slurries. • Dry sorbent injection systems.
Formation CO ₂ Releases	The atmospheric release of naturally or artificially occurring CO ₂ originally present in the produced crude oil and natural gas. Formation CO ₂ is most often extracted in the gas sweetening process.
Froth Treatment	A process for recover of bitumen from the water, bitumen and solids froth produced in a hot water extraction process.
Fuel Combustion	This accounts for the emissions from the consumption of all types of fuel typically encountered at oil and natural gas facilities (i.e., natural gas, propane and diesel) in both internal (reciprocating engines and gas turbines) and external (heater and boilers) combustion devices. Typically, emissions are estimated based on measured fuel volumes and published combustion emission factors.

Term	Definition
Fugitive Emissions	<p>The term "fugitive emissions" is very ambiguous. Typically, it is interpreted to mean unintentional releases, and often is thought to mean only equipment leaks. However, IPCC applies a much broader definition which basically classifies all sources of emissions in the energy sector into two categories: those from fuel combustion for the purpose of producing useful energy (e.g., heat or mechanical energy) and those from everything else (e.g., venting, flaring, incineration, equipment leaks, storage and handling losses, inspection and maintenance activities, purging activities, spills and accidental releases), with this latter category being referred to as fugitive emissions.</p>
Fugitive Equipment Leaks	<p>Fugitive equipment leaks are the loss of process fluid to the environment past a seal, connector (threaded or mechanical), cover, valve seat, flaw or minor damage point. In most cases these losses are unintentional and occur due to factors such as normal wear and tear, improper assembly or use, manufacturing defects, damage during installation, inspection or maintenance, corrosion, fouling during use and environmental effects (e.g., vibrations and thermal cycling). However, in some cases, such as certain pump and compressor seals, these components may actually be designed to leak a certain amount to continuously remove heat and debris away from the moving contact surfaces. In principle, none of the listed sources are 100 percent reliable or can be guaranteed to never leak. In practice, most equipment components do not have any measurable leakage, and most of those that do, contribute very little. Most of the emissions from fugitive equipment leaks tend to be contributed by only a few components at each site. Collectively, fugitive equipment leaks are a large, if not the largest, contributor of organic emissions at most types of facilities in the oil, natural gas, petroleum refining and petrochemical industries.</p> <p>Some of the potential reasons routine inspection and maintenance programs may not adequately control fugitive equipment leaks are as follows:</p> <ul style="list-style-type: none"> • Beyond pressure tests and rudimentary leak checks that may be done when equipment is first put into service, normal inspection and maintenance programs tend to rely on visual, audible and olfactory indicators as an ongoing means of leak detection thereafter, and then usually only focus on sources that are conveniently assessable. Thus, leaks get missed because they are out of normal sight, are elevated and don't produce odours at ground level until the plume drifts some distance downwind, occur in noisy areas, or some combination thereof. • Workers become desensitized to smells and other sensory indicators of leaks. • Few companies apply predictive maintenance techniques. A reactive, rather than a proactive, approach is usually taken. • Leak detection and repairs do not receive high priority and workers are not given adequate time and tools to perform a proper job. • Corporate management systems and employee incentive programs normally do not quantify the benefits of leak control and the value of reduced or avoided emission. Consequently, the typical

Term	Definition
	<p>emphasis of companies on increasing revenues and production while minimizing maintenance and operating costs actually discourages the expenditure of time and resources on leak control and emission reduction measures.</p> <p>The need for maintenance generally increases as the equipment ages; however, as the remaining anticipate life of a facility decreases, companies become reluctant to sustain the necessary level of maintenance investment.</p> <p>A formal leak detection and repair (LDAR) program comprises the systematic inspection of equipment components specifically for leaks using US EPA Method 21 (or equivalent technique) at regular intervals of once annually, and more frequently, if needed to maintain leak frequencies below maximum allowable limits, the application of objective leak definitions (e.g., 10,000 ppm screening value), rules regarding the scheduling of repairs, use of database applications to manage survey results and track performance over time, and the use of survey results to guide material, component and maintenance specifications in efforts for continuous improvement. Typically, formal leak detection and repair programs are either a regulatory requirement or a condition of the operating approvals at chemical plants and petroleum refineries.</p>
Gas Distribution	The delivery of natural gas from high-pressure transmission systems to customers.
Gas Distribution Network	The network or piping and other transportation equipment used to deliver natural gas to customers.
Gas Fractionation	A gas fractionation system is a cryogenic process for separating natural gas and refinery/upgrader off-gases into its constituent fractions to recover C ₂₊ (Ethane+) or C ₃₊ (Propane+) hydrocarbons.
Gas Lift Well	A well producing fluids into the tubing/annulus with the assistance of injected gas alone or in conjunction with mechanical equipment.
Gas Market	Total end-user (i.e., industrial, commercial and residential) natural gas demand.
Gas Oil	A medium distillate oil from the hydroprocessing unit at refineries and upgraders, which is used to produce diesel fuel. Sub-categories are vacuum gas oil (VGO) and straight-run gas oil.
Gas Plant - Acid Gas Flaring	A gas processing plant in which the acid gas (CO ₂ and H ₂ S) extracted from the raw inlet gas contains sufficiently small quantities of sulphur that it can meet provincial sulphur emission and air quality requirements by simply flaring the acid gas. Supplemental fuel is typically required to ensure stable operation of the acid gas flare
Gas Plant - Acid Gas Injection	A gas processing plant in which the acid gas (CO ₂ and H ₂ S) extracted from the raw inlet gas is injected underground into an appropriate reservoir.
Gas Plant - Straddle	A gas processing plant located on or near a gas transmission line that removes residual natural gas liquids from the gas and returns the residue gas to the line.
Gas Plant -	A gas processing plant at which elemental sulphur is extracted from the acid gas (CO ₂ and H ₂ S)

Term	Definition
Sulphur Recovery	prior to incineration.
Gas Plant - Sweet	A gas processing plant which processes natural gas containing less than 0.01 mole/kmole of H ₂ S.
Gas Plant Condensate	A natural gas processing plant product, mostly pentanes and heavier hydrocarbons, recovered and separated as liquids at the gas inlet separators or scrubbers in natural gas processing plants or field facilities.
Gas Production	Total natural gas output from oil and natural gas wells.
Gas Storage	Natural gas storage is the accumulation of natural gas in caverns, spheres or in a liquefied state at facilities usually located close to consuming areas for use in servicing peak demands.
Gas Sweetening	<p>A process used to remove hydrogen sulphide [H₂S] and carbon dioxide [CO₂] from a gas stream. These components are removed because they can form acidic solutions when they contact water, which will cause corrosion problems in gas pipelines.</p> <p>In a sweetening process, different types of ethanolamine can be used, including monoethanolamine (MEA), diethanolamine (DEA), diglycolamine (DGA) and methyldiethanolamine (MDEA). Hydrogen sulphide and carbon dioxide are absorbed by the ethanolamine and sweet gas leaves at the top of the absorber.</p> <p>The ethanolamine is heated and acid gas (hydrogen sulphide and carbon dioxide gases) and water vapor are obtained. The water is removed while the acid gas can be flared or further treated in a sulphur recovery unit to separate out elemental sulphur. Finally, the lean ethanolamine is returned to the absorber.</p>
Gas Transmission	The transport (usually by pipelines) of natural gas at high pressure from producing areas to consuming areas.
Gas Well	<p>Any well which produces:</p> <ul style="list-style-type: none"> • Natural gas not associated or blended with crude petroleum oil at the time of production. • Hydrocarbons having a gas-to-oil ratio of greater than 100,000 cubic feet of natural gas for each barrel of crude petroleum oil from the same producing horizon. • Natural gas from a formation or producing horizon productive of gas only encountered in a wellbore through which crude petroleum oil also is produced through the inside of another string of casing or tubing.
Gas-Condensate-Glycol (GCG) Separator	A two- or three-phase separator through which the “rich” glycol stream of a glycol dehydration unit is passed to remove entrained gas and hydrocarbon liquid. The GCG separator is commonly referred to as a flash separator or flash tank.
Gas-to-Oil Ratio (GOR)	The number of standard cubic meters of natural gas produced per liter of crude oil or other hydrocarbon liquid.
Global Warming Potential (GWP)	This is the amount of radiative forcing on the climate produced per unit mass of a specific greenhouse gas relative to that produced by CO ₂ . For example, CO ₂ has a GWP of 1 while CH ₄

Term	Definition
	and N ₂ O have GWPs of 25 and 298, based on a 100-year time horizon as published in the IPCC fourth assessment report . These values include both direct and indirect effect. Additionally, these GWP values are required for national reporting of GHG emissions to the UNFCCC Secretariat starting in 2013 and replace IPCC second assessment report GWPs for CH ₄ and N ₂ O.
Glycol Dehydrator	A device in which a liquid glycol including, but not limited to, ethylene glycol, diethylene glycol, or triethylene glycol absorbent, directly contacts a natural gas stream and absorbs water in a contact tower or absorption column (absorber). The glycol contacts and absorbs water vapour and other gas stream constituents from the natural gas and becomes “rich” glycol. This glycol is then regenerated in the glycol dehydration unit reboiler. The “lean” glycol is then recycled.
Glycol Dehydrator Reboiler Vent	The vent through which exhaust from the reboiler of a glycol dehydrator passes from the reboiler to the atmosphere or to a control device.
Greenhouse Gases	<p>These are substances that cause radiative forcing on the climate (i.e., contribute to global warming) when emitted into the atmosphere. Current focus is on those greenhouse gases increasing in atmospheric due to human activities, primarily CO₂, CH₄, CFCs and N₂O.</p> <p>Continued global warming could be expected to result in a significant rise in the present sea level, altered precipitation patterns and changed frequencies of climatic extremes. The potential effects of these changes include altered distribution and seasonal availability of fresh water resources, reduced crop yields and forest productivity and increased potential for tropical cyclones.</p>
Heat Rate	The amount of heat energy (based on the net or lower heating value of the fuel), which must be input to a combustion device to produce the rated power output. Heat rate is usually expressed in terms of net J/kWh.
Heater Treater	A vessel that heats an emulsion and removes water and gas from the oil to raise it to a quality acceptable for a pipeline or other means of transport. A heater-treater is a combination of a heater, free-water knockout, and oil and gas separator.
Heavy Crude Oil	A category of crude oil characterized by relatively high viscosity, a higher carbon-to-hydrogen ratio, and a relatively high density - typically. 900 kg/m ³ or more (25° or less API) Heavy crude oil typically is more difficult to extract with conventional recovery techniques and is more costly to refine.
High Vapour Pressure (HVP) Hydrocarbon	Any hydrocarbon or stabilized hydrocarbon mixture with a Reid vapour pressure of 110 kPa or greater as determined in accordance with ASTM D323 Reid method. Some examples of these hydrocarbons are liquid ethane, ethylene, propane, butanes, and pentanes.
High Vapour Pressure (HVP) Pipeline	Pipeline system transporting HVP hydrocarbon mixtures in the liquid or quasi-liquid state (see the definition for HVP hydrocarbon product).

Term	Definition
Hot Water Extraction	An extraction process whereby oil sand, hot water, steam and reagents are mixed to extract bitumen at a temperature of about 80°C.
Hydrate Control	The suppression of hydrate formation in natural gas gathering systems by dehydration, methanol addition or heat addition.
Hydro Cracker	A process unit for reducing heavy hydrocarbons into lighter fractions, using hydrogen and a catalyst.
Hydro Treater	A unit which removes sulphur and nitrogen from the components of crude oil by the catalytic addition of hydrogen. In addition to sulphur and nitrogen removal, hydrotreating reduces the amount of aromatic hydrocarbons that can give jet kerosene a poor smoke point and diesel fuel a poor cetane number.
Hydrocarbon Dew-Point Control	A process for removing condensable hydrocarbons from natural gas to control the temperature at any given pressure at which liquid hydrocarbon initially condenses from a gas or vapour.
Hydrocracking	A process for reducing heavy hydrocarbons into lighter fractions, using hydrogen and a catalyst.
Hydrogen Plant	<p>The hydrogen plant produces high-purity hydrogen required as feed for the Hydrocracker Reaction Unit, Gas Oil Unit and Naphtha/Jet Hydrotreating Unit at a refinery or upgrader. There the hydrogen is consumed by hydrogenation, desulphurization, and denitrication reactions.</p> <p>The most common method of hydrogen production is the steam reforming process. The main process step involves the reaction of steam with a hydrocarbon over a catalyst at around 750 to 800°C (1380 to 1470°F) to form hydrogen and carbon oxides. However, there are several other steps to remove impurities and maximize hydrogen production. The main steps involved are as follows:</p> <ul style="list-style-type: none"> • Feedstock Purification - removal of poisons such as sulphur and chloride to maximize the life of the downstream steam reforming and other catalysts. • Steam Reforming - the main hydrogen-producing reaction. A number of distinctive process designs are available for the steam reforming reaction. The 'classical' high-pressure and high-temperature process design is used to generate hydrogen for use in refinery or chemical applications. However, a low-pressure and carbon-dioxide-rich variant is used to generate gas for direct reduction plants (DRP) while technology based on adiabatic reforming is used to produce Towns Gas. • Shift Conversion - carbon monoxide reacts with steam to produce carbon dioxide and additional hydrogen. This is often done in two stages: High Temperature Shift (HTS) and Low Temperature Shift (LTS). • Product Purification - in older designs, carbon dioxide is removed in a liquid absorption system and finally the product gas goes through a methanation step to remove residual traces of carbon oxides. In most new plants, a Pressure Swing Absorption (PSA) unit is used instead, producing 99.99% product hydrogen and an off-gas used in the fuel system.
Hydrotreater	A unit which removes sulphur and nitrogen from the components of crude oil by the catalytic

Term	Definition
	addition of hydrogen. In addition to sulphur and nitrogen removal, hydrotreating reduces the amount of aromatic hydrocarbons that can give jet kerosene a poor smoke point and diesel fuel a poor cetane number.
Hydrotreating	A process for treating petroleum fractions from atmospheric or vacuum distillation units (e.g., naphthas, middle distillates, reformer feeds, residual fuel oil, and heavy gas oil) and other petroleum (e.g., catalytic cracked naphtha, coker naphtha, gas oil, etc.) by placing these feedstocks in contact with substantial quantities of hydrogen under high pressure and at a high temperature in the presence of a catalyst. Hydrotreating includes desulphurization, removal of nitrogen and metals, and conversion of polyaromatics and olefins to paraffins. It is usually a final stage in the upgrading process.
Incinerator	An enclosed combustion device that is used for destroying organic compounds. Auxiliary fuel may be used to heat waste gas to combustion temperatures. An energy recovery section is not physically formed into one manufactured or assembled unit with the combustion section; rather, the energy recovery section is a separate section following the combustion section and the two are joined by ducts or connections carrying flue gas. The above energy recovery section limitation does not apply to an energy recovery section used solely to preheat the incoming vent stream or combustion air.
Industrial Disposal Well	A well used for the disposal of processing wastes from a refinery or chemical plant or brine from preparation or operation of a storage cavern.
Industrial Meter Set	Metering facility that transfers gas from the distribution system to a large industrial customer. Typically, gas is supplied at intermediate or high pressure (400 to 3000 kPag [60 to 435 psig] or more), and is metered and pressure regulated.
Injection Facility	A facility constructed and operated for the purpose of moving (waste) product(s) into a petroleum reservoir.
Injection Well	A well used primarily to inject fluids into a reservoir as part of an enhanced recovery, experimental, or pilot scheme.
Inlet Separator	A vessel located at the entrance to a hydrocarbon facility that separates the incoming stream into different components, such as natural gas and liquids.
In-Situ Recovery	Recovery of bitumen (oil sands) from a reservoir using a series of wells. This is in contrast to oil sands recovery by mining
Integral Compressor	A reciprocating compressor that shares a common crankshaft and crankcase with the engine.
Key Sources	Based on the IPCC (2000) definition, key source categories are those categories that, when ranked from largest to smallest based on their emission contributions, collectively account for the first 95 percent of total emissions at the site.
Kinetics and Thermodynamics	Thermodynamic equilibrium defines the maximum extent to which a chemical reaction, such as combustion, may proceed (i.e., the point at which there is no further tendency for change).

Term	Definition
	Chemical kinetics determine the rate at which a chemically reacting system will approach the point of thermodynamic equilibrium.
LC-Fining	An expanded ebulating bed hydroprocessing technology used to continuously crack bitumen into lighter products through the catalytic addition of hydrogen.
Lease Fuel	Natural gas used in well, field, and lease operations (such as natural gas used in drilling operations, heaters, dehydrators, and field compressors) and as fuel in natural gas processing plants.
Lease Separator	Facility located at the surface for the purpose of separating casinghead gas from produced crude oil and water at the temperature and pressure conditions of the separator.
Light/Medium Crude Oil	A category of crude oil characterized by relatively low viscosity, a lower carbon-to-hydrogen ratio, and a relatively low density - typically less than 900 kg/m ³ (greater than 25° API).
Line Heater	An indirectly-fired heater used to heat the fluid in the pipeline to above hydrate or freezing temperatures.
Liquefied Natural Gas (LNG)	Natural gas that has been refrigerated to -160°C to condense it into a liquid. The liquefaction process removes most of the water vapour, butane, propane, and other trace gases, that are usually included in ordinary natural gas. The resulting LNG is usually more than 98 percent pure methane.
Liquefied Petroleum Gas (LPG)	A natural gas mixture composed of mainly ethane, propane, and butanes, with small amounts of pentanes plus (C ₅₊) in any combination. The fluid is usually gaseous under standard reference conditions but becomes a liquid under pressure.
Loading/Unloading Losses	When tankers (truck, rail or marine) are used to transport hydrocarbons a certain quantity of hydrocarbon vapours may be released to the atmosphere during loading and unloading operations. Emissions occur when vapours in a tanker are expelled as liquid is added. The quantity of emissions is dependent on the degree of saturation of the vapour space, the type of loading that is employed (i.e., splash or submerged), properties of the product and the amount of product transferred.
LPG Storage	A facility for storing liquefied petroleum gas (e.g., C ₂ , C ₃ or C ₄). Typically, the LPG is stored in pressurized spherical or cylindrical steel tanks, but it may also be stored in caverns and various refrigerated containers.
Marine Terminal	A system or arrangement of tanks and other surface equipment for receiving oil from, or transferring oil to, marine tankers.
Market	The industrial, commercial and residential demand for a product.
Meter Station	A facility whose purpose is to measure the volume of natural gas passing through a pipeline. Orifice meters are used in most cases but turbine, vortex shedding and ultrasonic meters are also used.

Term	Definition
Methane Content of Natural Gas	The volume of methane contained in a unit volume of natural gas at standard temperature, 15°C, and pressure, 101.325 kPa.
Miscellaneous Pipeline Equipment	Aboveground or exposed equipment components (e.g., isolation/block valves, pressure-relief valves, connectors, etc.) used on the pipeline that do not occur at an actual distribution station. Buried components are deemed to be part of the piping.
Natural Gas	A naturally occurring mixture of hydrocarbon and non-hydrocarbon compounds existing in the gaseous phase or in solution with hydrocarbon liquids in geologic formations beneath the earth's surface. The principal hydrocarbon constituent is methane.
Natural Gas Battery	A system or arrangement of surface equipment that receives primarily natural gas from one or more wells prior to delivery to a natural gas gathering system, to market, or to other disposition. Natural gas batteries may include equipment for measurement and for separating inlet streams into natural gas, hydrocarbon liquid, and/or water phases. There are many occurrences of gas battery codes being assigned for the purpose of being a proration hub. In these instances there is no equipment onsite except a meter.
Natural Gas Cycling	An enhanced petroleum recovery technique that takes produced natural gas and condensate and injects it back into the reservoir to increase pressure and increase the production of natural gas liquids.
Natural Gas Group Battery	A production facility consisting of two or more flow-lined natural gas wells having individual separation and measurement equipment but with all equipment sharing a common surface location.
Natural Gas Injection	An enhanced crude oil recovery technique in which natural gas is compressed into a producing reservoir through an injection well to drive oil to the well bore and the surface.
Natural Gas Processing Plant	A natural gas processing facility for extracting from natural gas helium, ethane, or natural gas liquids (NGL), and/or the fractionation of mixed NGL to natural gas products. A natural gas processing plant may also include natural gas purification processes for upgrading the quality of the natural gas to be marketed to meet contract specifications (i.e., for removing contaminants such as water, H ₂ S, CO ₂ , and possibly adjusting the heating value by the addition or removal of nitrogen). The inlet natural gas may or may not have been processed through lease separators and field facilities.
Natural Gas Proration (or Fieldgate) Battery	A production facility consisting of two or more flow-lined natural gas wells having common separation and measuring equipment. Total production is prorated to each well based on individual well tests. Individual well production tests can occur at the central site or at remote satellite facilities.
Natural Gas Satellite Battery	A small group of surface equipment (not including storage tanks) located between a number of wells and the main natural gas battery that is intended to separate and measure the production from each well, after which the production is recombined and piped to the main natural gas battery for treating and storage or delivery.

Term	Definition
Natural Gas Single Battery	A production facility for a single gas well where production is measured at the wellhead. Production is delivered directly and is not combined with production from other wells prior to delivery to a gas plant, gas gathering system, or other disposition.
Natural Gas Test Battery	A production facility for natural gas well testing of gas production prior to commencement of regular production.
Natural Gas Gathering System	A network of natural gas pipelines used to move natural gas from wells and production facilities to a final treatment or processing point. The gathering system may also include compressors, line heaters and dehydrators.
Nitrogen Oxides (NO _x)	<p>The total of all forms of oxidized nitrogen at a given measurement point. The primary forms of NO_x emitted by combustion devices are NO and NO₂; however, other forms may include N₂O, NO₃, N₂O₄ and N₂O₅. Convention is to express total NO_x in terms of equivalent NO₂.</p> <p>There are three mechanisms for formation of NO_x in combustion processes: thermal fixation of nitrogen from the combustion air (thermal NO_x), oxidation of fuel-bound nitrogen compounds (chemical NO_x), and the formation of CN compounds in the flame zone which subsequently react to form NO (prompt NO_x). Thermal NO_x is the predominant form of NO_x produced from natural gas combustion. The conditions that govern the formation of thermal NO_x are the peak temperature, residence time at the peak temperature and the availability of oxygen while that temperature exists.</p> <p>Fuel-bound nitrogen is an important source of NO_x where appreciable amounts of such fuels are used. The extent of conversion of fuel-bound nitrogen to NO is nearly independent of the parent fuel molecule, but is strongly dependent on the local combustion environment and on the initial amount of fuel-bound nitrogen.</p> <p>Prompt NO_x is associated with the combustion of hydrocarbons. The maximum formation of prompt NO_x is reached on the fuel-rich side of stoichiometric. It remains high through a fuel-rich region, and then drops off sharply when the fuel-air ratio is about 1.4 times the value at stoichiometric.</p> <p>NO_x controls can be classified into two types: post combustion methods and combustion control techniques. Post combustion methods address NO_x emissions after formation while combustion control techniques prevent the formation of NO_x during the combustion process. Post combustion methods tend to be more expensive than combustion control techniques.</p> <p>Post combustion control methods include selective non-catalytic reduction, and selective catalytic reduction.</p>

Term	Definition
	Combustion control techniques depend on the type of combustion device and fuel. Nonetheless, they generally are designed to achieve lower combustion temperatures without significantly affecting combustion efficiency and power output, and to avoid/minimize the use of nitrogen containing fuels.
Non-Associated Natural Gas	Natural gas that is produced from a predominantly natural gas pool (e.g., natural gas that is not associated with crude oil, including bitumen).
Observation Well	A well used to monitor performance in an oil or gas reservoir, oil sands deposit, or aquifer.
Offshore	The geographic area which lies seaward of the coastline. In general, the term “coastline” means the line of ordinary low water along that portion of the coast which is in direct contact with open sea or the line marking the seaward limit of inland water.
Offshore Production Platform	A platform from which development wells are drilled and that carries all the associated processing plants and other equipment needed to maintain a field in production.
Offshore Well	A well that is bottomed at, or produces from a point that lies seaward of the coastline.
Oil Production	The output crude oil from oil production facilities.
Oil Shale	A laminated, sedimentary rock that contains a solid, waxy hydrocarbon called kerogen which is commingled with the rock structure. Shale oil is the hydrocarbon produced from the decomposition of the kerogen when oil shale is heated in an oxygen-free environment. Raw shale oil resembles a heavy, viscous, low-sulphur high-nitrogen crude oil but can be upgraded to produce a good-quality sweet crude oil.
Oil Transportation System	The system for transport (by pipelines, tanker, truck or rail car) of crude oil from producing areas to upgraders and refineries.
Oil Well	Any well which produces one barrel or more of crude petroleum oil to each 100,000 cubic feet of natural gas.
Open-Ended Valves and Lines	<p>Any valve that may release process fluids directly to the atmosphere in the event of leakage past the valve seat. The leakage may result from improper seating due to an obstruction or sludge accumulation, or because of a damaged or worn seat. An open-ended line is any segment of pipe that may be attached to such a valve and that opens to the atmosphere at the other end.</p> <p>Few open-ended valves and lines are designed into process systems. However, actual numbers can be quite significant at some sites due to poor operating practices and various process modifications that may occur over time.</p> <p>Some common examples of instances where this type of source may occur are listed below:</p> <ul style="list-style-type: none"> •scrubber, compressor-unit, station and mainline blowdown valves, • supply-gas valve for a gas-operated engine starter (i.e., where natural gas is the supply medium),

Term	Definition
	<ul style="list-style-type: none"> • instrument block valves where the instrument has been removed for repair or other reasons, and • purge or sampling points.
Operator	The entity appointed by venture stakeholders to take primary responsibility for day-to-day operations and activities for a specific plant or activity.
Particulate Matter (PM)	<p>Particulate matter is that portion of the flue gas which exists as a solid or liquid droplet when it leaves the stack and cools to ambient conditions. Carbonaceous particulate that forms from gas-phase processes is generally referred to as soot, and that developed from pyrolysis of liquid hydrocarbon fuels is referred to as coke or cenospheres.</p> <p>The potential for particulate emissions is generally dependent on the composition of the fuel and the type of combustion device. Combustion of natural gas produces very small amounts of particulate emissions compared to other types of fuels. The amount of particulate emissions will tend to increase with the molecular weight of the gas. Reciprocating engines tend to produce the most particulate matter while heaters and boilers produce the least. Most of the particulate matter emitted by reciprocating engines is reportedly due to lubricating oil leakage past the piston rings. Flares can also be important sources of particulate matter.</p> <p>Particulate emissions generally are classified as PM, PM₁₀, PM_{2.5} and PM₁ according to the maximum diameter of the material, namely, total PM, and PM with a diameter less than 10, 2.5 and 1 microns, respectively. PM₁₀ and smaller particulate matter are of greatest concern because of their ability to bypass the body's natural respiratory filtering system.</p>
Pentanes Plus	A mixture of hydrocarbons, mostly pentanes and heavier hydrocarbons, extracted from natural gas. It includes natural gasoline, isopentane and gas plant condensate.
Petroleum	A term sometimes used as a substitute for crude oil and sometimes as a collective term for natural gas and crude oil.
Petroleum Bulk Terminals	System or arrangement of tanks and other surface equipment operated by refining, pipeline, and bulk terminal companies which (1) receive their principal products by tankers, barges, or pipelines, or (2) have a total combined capacity of 8 000 m ³ (50,000 barrels) or more, regardless of the transportation means by which products are received.
Petroleum Coke	Solid, black hydrocarbon which is left as a residue after the more valuable hydrocarbons have been removed from bitumen or crude oil by heating it to high temperatures.
Petroleum Distribution Network	The network or piping, tankers, trucks, rail cars and transportation equipment used to deliver petroleum products to customers.
Petroleum Liquids	Liquid hydrocarbons, that is crude oil, diluted bitumen, natural gas liquids, condensate, etc.
Petroleum Market	The industrial, commercial and residential demand for petroleum products.
Photochemical	Photochemical oxidants are a class of pollutants produced by the reaction of VOCs and NO _x in

Term	Definition
Oxidants	<p>the presence of solar radiation which accumulate in the air near ground level. Ozone (O₃) is the principal oxidant produced; however, significant levels of peroxyacetyl nitrate (PAN) and nitrogen dioxide (NO₂) also occur.</p> <p>Exposure to increased ozone concentrations can cause short-term impairment of the respiratory system and is suspected of playing a role in the long-term development of chronic lung disease.</p> <p>Damage to vegetation caused by ozone is reported (Wilson et al., 1984) to be greater than that caused by commonly occurring air contaminants such as SO₂, NO₂, or acidic precipitation. Also, elevated ozone concentrations produce smog and cause deterioration and cracking of rubber products.</p>
Pig	A device, with optional elastomer cups, that is inserted into a pipeline and pushed along by the flowing fluid to perform any one of a number of functions: cleaning, displacement, batching, or internal inspection. It gets its name from the squealing noises the pipeline pigs made when first used.
Pig Launcher	A piping arrangement that allows pigs to be launched into a pipeline without stopping flow.
Pig Passage Indicator	A device installed on a pipeline to indicate the passage of a pig. A visual or electrical indication, or combination thereof, is given when the pig passes. Pig indicators can also be used in automated systems for valve sequencing. A non-intrusive model, which does not require a tap, is also available.
Pig Receiver	A piping arrangement that allows pigs to be removed from a pipeline without stopping flow.
Pipeline Fuel	Natural gas consumed in the operation of a natural gas pipeline, primarily in compressors.
Pipeline Leak	Fugitive emission through a small opening in the wall of the pipeline (e.g., due to corrosion or material defects) or from valves, fittings or connectors attached to the pipeline.
Pipeline Terminal	System or arrangement of tanks and other surface equipment principally for receiving oil from, and transferring oil to, pipelines. The terminal may also feature facilities for blending petroleum liquids, and loading and unloading facilities for tank trucks and/or tank rail cars.
Pipelines	A network of pipes used to transport gases and liquids.
Plastic Pipelines	Pipelines made of various types of plastic, i.e., including polyethylene (PE), polyvinyl chloride (PVC), acrylonitrile butadiene styrene (ABS), etc.
Pool	Synonymous with the term reservoir; however, in certain situations, a pool may consist of more than one reservoir.
Power Output	For engines it is the net shaft power available after all losses and power take-offs (e.g., ignition-system power generators, cooling fans, turbo chargers and pumps for fuel, lubricating oil and liquid coolant) have been subtracted. For heaters and boilers it is the net heat transferred to a target process fluid or system.
Pressure-Relief or	These are used to protect process piping and vessels from being accidentally over-pressured.

Term	Definition
Safety Valves	<p>They are spring loaded so that they are fully closed when the upstream pressure is below the set point, and only open when the set point is exceeded. Relief valves open in proportion to the amount of overpressure to provide modulated venting. Safety valves pop to a full-open positions on activation.</p> <p>When relief or safety valves reseal after having been activated, they often leak because the original tight seat is not regained either due to damage of the seating surface or a build-up of foreign material on the seat plug. As a result, they are often responsible for fugitive emissions. Another problem develops if the operating pressure is too close to the set pressure, causing the valve to "simmer" or "pop" at the set pressure.</p> <p>Gas that leaks from a pressure-relief valve may be detected at the end of the vent pipe (or horn). Additionally, there normally is a monitoring port located on the bottom of the horn near the valve.</p>
Primary Recovery	The production of crude oil using natural reservoir pressure and/or a simple downhole pump.
Process Heater	An enclosed device using a controlled flame, the primary purpose of which is to transfer heat to a process fluid or process material that is not a fluid, or to a heat transfer material for use in a process (rather than for steam generation).
Process Vessel	A heater, dehydrator, separator, treater, or any vessel used in the processing or treatment of produced gas or oil.
Produced Water	Water that is extracted from the earth from a crude oil or natural gas production well, or that is separated from crude oil, condensate, or natural gas after extraction.
Produced Water Storage	Atmospheric storage tanks used to store produced water from oil and natural gas facilities prior to transporting it to a disposal or re-injection facility.
Producing Well	A well producing hydrocarbons from a petroleum reservoir or a bituminous [oil] sands deposit.
Product Blender	A storage tank or inline mixer for blending crude oils and condensates to meet product specifications.
Production Well	Any hole drilled in the earth from which crude oil, condensate, or field natural gas is extracted.
Products of Incomplete Combustion	These are any compounds, excluding CO ₂ , H ₂ O, SO ₂ , HCl and HF, that contain C, H, S, Cl or F and occur in the flue gas stream. These compounds may result from thermodynamic, kinetic or transport limitations in the various combustion zones. All input combustibles are potential products of incomplete combustion. Intermediate substances formed by dissociation and recombination effects may also occur as products of incomplete combustion (CO is often the most abundant product of incomplete combustion formed).
Protected Steel Pipelines	Steel pipelines that are cathodically protected.
Pump Seals	Positive displacement pumps are normally used for pumping hydrocarbon liquids at oil and

Term	Definition
	<p>natural gas facilities. Positive displacement pumps have a reciprocating piston, diaphragm or plunger, or else a rotary screw or gear.</p> <p>Packing, with or without a sealant, is the simplest means of controlling leakage around the pump shaft. It may be used on both the rotating and reciprocating pumps. Specially designed packing materials are available for different types of service. The selected material is placed in a stuffing box and the packing gland is tightened to compress the packing around the shaft. All packings leak and generally require frequent gland tightening and periodic packing replacement.</p> <p>Particulate contamination, overheating, seal wear, sliding seal leakage and vibration will contribute to increased leakage rates over time.</p>
Pumping Station	System or arrangement of tanks and other surface equipment located at intervals along a main pipeline to maintain flow to the terminal point.
Pumping Well	An oil well that requires a pump to bring the oil to the surface. Either a pumpjack (polished rod pump) or a progressive cavity pump may be used.
Pumps	Mechanical devices used to cause liquids to flow by physical displacement.
Purge Gas	For safe operation, flare systems require a constant purge of gas (usually fuel gas). The purge rate is usually determined when the system is designed. The purge gas rate is sometimes set by installing an appropriate orifice in the purge fuel line but most often it is set by partially opening a valve. Purge gas rates are not typically measured.
Receipt Meter Station	A meter station for measuring the amount of gas being supplied by a given source (e.g., gas processing plant or a gas battery) to a natural gas transmission system.
Reciprocating Compressor	A piece of equipment that increases the pressure of a process gas by positive displacement, employing linear movement of the drive shaft.
Reciprocating Compressor Packing Systems	<p>These are used on reciprocating compressors to control leakage around the piston rod on each cylinder. Conventional packing systems have always been prone to leaking a certain amount, even under the best of conditions.</p> <p>According to one manufacturer, leakage from within the cylinder or through any of the various vents will be on the order of 1.7 to 3.4 m³/h under normal conditions and for most gases. However, these rates may increase rapidly as normal wear and degradation of the system occurs.</p>
Reduced Sulphur Compounds (RSCs)	Any compounds containing the sulphur atom in its reduced oxidation state. These are taken to be any sulphur-containing compounds except SO _x .
Refinery	A plant where crude oil is separated by distillation into light and heavy fractions which are then converted by various methods, such as cracking, reforming, alkylation, polymerization and isomerisation, into usable products or feedstocks for other processes. The mixtures of new

Term	Definition
	compounds formed are separated using methods such as fractionation and solvent extraction.
Refinery Processing Gain	This is the volumetric amount by which total output is greater than input. This difference is due to the processing of crude oil into products that, in total, have lower specific gravity than the crude oil processed. Therefore, in terms of volume, the total output of products is greater than input.
Refinery Processing Loss	The volumetric amount by which total output is less than input for a given period of time. This difference is due to the processing of crude oil into products that, in total, have a higher specific gravity than the crude oil processed. Thus, in terms of volume, the total output is smaller than the input. Physical losses also contribute (i.e., losses to flaring, atmosphere, etc.).
Refrigeration	A process for chilling natural gas to extract condensable heavier-than-methane hydrocarbon fractions (e.g., C ₂ , C ₃ , and C ₄₊) and controlling the hydrocarbon dew point of the natural gas stream. This may be done using a Joule-Thompson or closed loop propane refrigeration unit for shallow cut extraction. For deep cut extraction a turbo expander and propane refrigeration unit are typically used.
Regulation Station	A facility whose purpose is to regulate the pressure of gas passing through a pipeline to a set level.
Reinjection	The injection of a gas or liquid back into the reservoir from which it originated.
Relief Device	A device used only to release an unplanned, non-routine discharge in order to avoid safety hazards or equipment damage. A relief device discharge can result from an operator error, a malfunction such as a power failure or equipment failure, or other unexpected cause that requires immediate venting of gas from process equipment to avoid safety hazards or equipment damage.
Reported Venting Storage Losses	<p>The sum of all vented volumes stated in production accounting statistics. These comprise normal evaporation losses, flashing losses and unintentional gas carry-through to storage tanks due to leakage past drain valves into tank inlet headers, inefficient gas-liquid separation in upstream vessels, malfunctioning level controllers, leakage past the seat of level control valves, or unintentional storage of high vapour pressure liquids in atmospheric tanks.</p> <p>Evaporative losses occur when volatile hydrocarbon products are stored in tanks that are vented to the atmosphere. As the product evaporates, the vapour space in the tank becomes saturated with vapours. These vapours are expelled during tank filling (working losses) and due to diurnal temperature and pressure changes (breathing losses).</p> <p>Flashing losses are characterized by a rapid boiling process. They occur when product with a true vapour pressure near or greater than atmospheric pressure is placed in atmospheric storage tanks or when hot product is run down to a tank containing a lighter product causing it to boil.</p>
Reservoir	A porous and permeable underground formation containing an individual and separate natural accumulation of producible hydrocarbons (oil and/or natural gas) which is confined by

Term	Definition
	impermeable rock or water barriers and is characterized by a single natural pressure system. In most situations, reservoirs are classified as oil reservoirs or as natural gas reservoirs by a regulatory agency. In the absence of a regulatory authority, the classification is based on the natural occurrence of the hydrocarbons in the reservoir as determined by the operator.
Residual Flare Gas	The sum of the flare purge gas flow and any leakage into the flare header. This is the total gas flow rate that occurs in the header to an intermittent flare during the periods between flaring events.
Residue Gas	Natural gas from which gas plant products (natural gas liquids), and in some cases non-hydrocarbons, have been extracted in natural gas processing plants.
Rural Gas Co-ops	A natural gas distribution system that delivers natural gas to rural customers by pipeline or other transport equipment.
Safety Device	<p>A device that meets both of the following conditions:</p> <ul style="list-style-type: none"> • it is not used for planned or routine venting of liquids, gases, or fumes from the unit or equipment on which the device is installed; and • it remains in a closed, sealed position at all times except when an unplanned event requires that the device open for the purpose of preventing physical damage or permanent deformation of the unit or equipment on which the device is installed (i.e., in accordance with good engineering and safety practices for handling flammable, combustible, explosive, or other hazardous materials). <p>Examples of unplanned events that may require a safety device to open include failure of an essential equipment component or a sudden power outage.</p>
Sales Meter Station	A meter station for measuring the amount of natural gas being withdrawn from a gas transmission system by a customer (e.g., gas distribution system, farm or industrial end user). It might include pressure-regulating equipment.
Secondary Recovery	The production of crude oil using reservoir flooding with water or natural gas.
Service Lines	<p>Service line is usually a short, small diameter pipeline that delivers natural gas from a distribution main or transmission pipeline to the customer. They are usually made of steel pipe or steel tubing (either cathodically protected or not) , or plastic (usually polyethylene, but sometimes polyvinyl chloride or other plastic), although copper tubing was also sometimes used in the past.</p> <p>Sizes vary from ½ to 2 NPS, with some commercial or industrial customers having service lines of much larger diameter.</p> <p>Service lines tied into transmission lines might operate at pressures exceeding the distribution pressure. They are called “high-pressure service lines” and require double regulation at the</p>

Term	Definition
	customer meter set. Typically, they operate at pressures above 860 kPag (125 psig). Steel pipelines that are not cathodically protected.
Service Well	<p>A well drilled or completed for the purpose of supporting production in an existing field. Wells of this class are drilled for the following specific purposes:</p> <ul style="list-style-type: none"> • gas injection (natural gas, propane, butane or flue-gas), • water injection, • steam injection, • air injection, • salt water injection, • water supply for injection, • observation, or • injection for in-situ combustion.
Shallow Natural Gas Well	A gas well less than 1000 m deep. The gas is usually low pressure and sweet. In some cases shallow gas may only require dehydration and compression prior to sales
Shut-in Well	A well that has been completed but is not producing. A well may be shut-in for tests, repairs, to await construction of gathering or flow lines, or better economic conditions.
Solution Natural Gas	Natural gas that is in solution with produced crude oil.
Sour Crude Oil	Crude oil containing free sulphur, hydrogen sulphide or other sulphur compounds.
Sour Natural Gas	Raw natural gas that contains quantities of hydrogen sulphide (H ₂ S), carbon dioxide (CO ₂), and other sulphide-based compounds in sufficient quantities to pose a public safety hazard if released or to result in unacceptable off-lease odours if vented to the atmosphere.
Stabilizer	A heated pressure vessel used to boil off the volatile fraction of a liquid stream to produce a less volatile product suitable for storage in tanks at atmospheric pressure.
Standard Reference Conditions	<p>Most equipment manufacturers reference flow, concentration and equipment performance data at ISO standard conditions of 15°C, 101.325 kPa, sea level and 0.0 percent relative humidity.</p> <p>The following equation shows how to correct pollutant concentrations measured in the exhaust to 3 percent oxygen (15% excess air) for comparison and regulatory compliance purposes:</p> $ppm(3\%) = \frac{21 - 3}{21 - O_2(actual)} \times ppm(actual)$
Steam Generators	A boiler used to generate steam for use in thermal oil production schemes.
Steam Methane Reforming	A process commonly used to convert natural gas to hydrogen for use in hydrotreating processes.

Term	Definition
Steam Separator	A vessel for separating steam and condensed water.
Steam-Assisted Gravity Drainage (SAGD) Well	A well used to produce heavy oil, particularly bitumen, with the assistance of thermal heating by steam.
Stock Tank Vapours	The evaporated product and solution gas present in the headspace of oil storage tanks that is vented to the atmosphere or to a vapour collection system.
Storage	Most transmission systems incorporate the use of storage caverns or spheres to help balance daily and seasonal variations in loads, and, therefore, are able to operate at nearly full capacity much of the time.
Storage Vessel	A tank or other vessel that is designed to contain an accumulation of crude oil, condensate, intermediate hydrocarbon liquids, or produced water and that is constructed primarily of non-earthen materials (e.g., wood, concrete, steel, plastic), which provide structural support.
Storage Vessel with the Potential for Flash Emissions	Any storage vessel that receives hydrocarbon liquids containing dissolved natural gas that will evolve from solution when the fluid pressure is reduced.
Storage Well	A well used to inject hydrocarbons into a storage reservoir or cavern.
Stripper Well	<p>An oil or gas well that is nearing the end of its economically useful life.</p> <p>This comprises any oil wells whose maximum daily average oil production is less than or equal to 10 bbls of oil, or any natural gas well whose maximum daily average gas production is less than or equal to 60 Mcf (1700 m³), during any 12-month consecutive time period.</p> <p>Often on stripper oil wells the casing is vented to the atmosphere to promote increased production by minimizing the downhole pressure at the reservoir face.</p>
Sub-Sea Wellhead	A wellhead installed on the sea floor and controlled remotely from a platform, a floating production facility or land.
Subsonic Flow	Flow where the local fluid velocity is less the speed of sound in that fluid at its flowing temperature and pressure.
Sulphur Oxides (SO _x)	Usually, almost all sulphur input to a combustion process as part of the fuel or waste materials being burned is converted to SO _x . Only a few percent of the available sulphur is emitted as sulphate particulate and other products of incomplete combustion. The produced SO _x is comprised mostly of SO ₂ (typically 95 percent) with the rest being SO ₃ . For simplification purposes it is assumed throughout this document that all input sulphur is converted to SO ₂ .
Sulphur Recovery	A sulphur recovery unit converts hydrogen sulphide removed from sour gases and hydrocarbon streams to elemental sulphur. The most widely used recovery system is the Claus process, which uses both thermal and catalytic-conversion reactions. A typical process produces elemental sulphur by burning hydrogen sulphide under controlled conditions. Knockout pots are used to

Term	Definition
	remove water and hydrocarbons from feed gas streams. The gases are then exposed to a catalyst to recover additional sulphur. Sulphur vapor from burning and conversion is condensed and recovered.
Suspended Well	A well in which production or injection operations have ceased for an indefinite period of time.
Suspension	The cessation of normal production, operation, or injection activities at a facility.
Sweet Natural Gas	Raw natural gas with a relatively low concentration of sulphur compounds, such as hydrogen sulphide.
Synthetic Crude Oil	A high quality, light, usually sweet, crude oil derived by upgrading heavy crude oil, particularly bitumen, through the addition of hydrogen or removal of carbon. It comprises mainly pentane and heavier hydrocarbons.
Tank	A device designed to contain materials produced, generated, and used by the petroleum industry that is constructed of impervious materials, such as concrete, plastic, fibreglass-reinforced plastic, or steel that provide structural support.
Tank Farm	A system or arrangement of tanks or other surface equipment associated with the operation of a pipeline that may include measurement equipment and line heaters, but does not include separation equipment or storage vessels at a battery.
Tank Truck	Any road vehicle carrying liquid or gaseous cargo in bulk.
Tanker	Any ship or other watercraft carrying liquid or gaseous cargo in bulk.
Tertiary Recovery	The production of crude oil using more sophisticated techniques such as reservoir flooding with CO ₂ or lighter hydrocarbons such as ethane. Tertiary recovery also encompasses all thermal recovery techniques.
Thermal Efficiency	<p>The percentage or portion of input energy converted to useful work or heat output. For combustion equipment, typical convention is to express the input energy in terms of the net (lower) heating value of the fuel. This results in the following relation for thermal efficiency:</p> $\eta = \text{Thermal Efficiency} = \frac{\text{Useful Work/Heat Output}}{\text{Net Heat/Energy Input}} \times 100\%$ <p>Alternatively, thermal efficiency may be expressed in terms of energy losses as follows:</p> $\eta = \left(1 - \frac{\Sigma \text{Energy Losses}}{\text{Net Heat/Energy Input}} \right) \times 100\%$ <p>Losses in thermal efficiency occur due to the following potential factors:</p> <ul style="list-style-type: none"> • exit combustion heat losses (i.e., residual heat value in the exhaust gases), • heat rejected through coolant and lube oil cooling systems (where applicable), • heat losses from the surface of the combustion unit to the atmosphere (i.e., from the body and associated piping of a heater, boiler or engine),

Term	Definition
	<ul style="list-style-type: none"> • air infiltration, • incomplete combustion, and • mechanical losses (e.g., friction losses and energy needed to run cooling fans and lubricating-oil pumps).
Thermal Recovery	The production of crude oil which involves the use of one or more thermal techniques whereby heat is introduced into the crude oil reservoir or bituminous sands (oil sands) deposit to enhance the ability of the crude oil to flow and thereby facilitate its recovery.
Total Hydrocarbons	All compounds containing at least one hydrogen atom and one carbon atom, with the exception of carbonates and bicarbonates.
Total Organic Compounds (TOC)	TOC comprises all VOCs plus all non-reactive organic compounds (i.e., methane, ethane, methylene chloride, methyl chloroform, many fluorocarbons, and certain classes of per fluorocarbons).
Total Petroleum Stocks	The volume of crude oil (including lease condensate), natural gas plant liquids and petroleum products held by crude oil producers, storers of crude oil, companies transporting crude oil by water, crude oil pipeline companies, refining companies, product pipeline companies, and by bulk terminal companies. Included are domestic oil and foreign oil that have cleared customs for domestic consumption (i.e., foreign oil in-transit to the receiving country and foreign oils held in bonded storage, to include oils in the foreign trades zone, are excluded from these stock statistics). All stocks are reported on a custody basis, regardless of ownership of the oils.
Transmission Pipeline	<p>A pipeline used to transport processed, unodourized natural gas to market (i.e., to gas distribution systems and major industrial customers). Most transmission pipelines also have some farm taps that provide gas to farmers located along the pipeline in areas where service from distribution systems is not readily available.</p> <p>The pipelines are usually constructed of steel, although aluminum is used for some lower pressure applications (generally up to 3450 kPa or 500 psig). The pipe sizes range from 60.3 mm to 1219.2 mm O.D. (2 to 48 NPS), with the mid-range sizes being most common. The operating pressures typically range from 1380 to over 6900 kPag (200 to 1000+ psig).</p>
Transmission Station	A station associated with a natural gas transmission pipeline that handles unodourized natural gas and which meters and/or regulates the natural gas pressure. It may be a Receipt/Sales Station, Border Meter Station or Transmission Farm Tap.
Transport System	A system for transporting crude oil, condensate and LPG to upgraders and refineries.
Treating	The application of processes to remove impurities from hydrocarbon streams such as water, carbon dioxide, hydrogen sulphide, and nitrogen.
Truck Terminal	A system or arrangement of tanks and other surface equipment receiving crude oil by truck for the purpose of delivering crude oil into a pipeline.
Turnaround	A scheduled large-scale maintenance activity wherein an entire process unit is taken offshore

Term	Definition
	for an extended period for comprehensive revamp and renewal.
Unreported Venting	Venting from processes or equipment that is not typically reported in production accounting data. Sources include: glycol dehydrator off-gas, loading/unloading losses, storage losses, pneumatic devices (e.g., chemical injection pumps, natural gas operated instrumentation), compressor start gas, purge gas and blanket gas that is discharged directly to the atmosphere.
Upgrader	A facility for upgrading heavy oil and crude bitumen into a lighter, sweeter, high-quality synthetic crude oil either through the removal of carbon (coking) or the addition of hydrogen (hydroprocessing).
Vacuum Distillation	Distillation under reduced pressure (less than atmospheric) which lowers the boiling points of the liquid mixture being distilled. This technique involves a relatively low temperature and prevents cracking or decomposition of the very heavy hydrocarbon stocks.
Valve	<p>A device for controlling the flow of a fluid. There are three main locations on a typical valve where leakage may occur: (1) from the valve body and around the valve stem, (2) around the end connections, or (3) past the valve seat. Leaks of the first type are referred to as valve leaks. Emissions from the end connections are classified as connector leaks. Leakage past the valve seat is only a potential source of emissions if the valve, or any downstream piping, is open to the atmosphere. This is referred to as an open-ended valve or line.</p> <p>The potential leak points on each of the different types of valves are, as applicable, around the valve stem, body seals (e.g., where the bonnet bolts to the valve body, retainer connections), body fittings (e.g., grease nipples, bleed ports), packing guide, and any monitoring ports on the stem packing system. Typically, the valve-stem packing is the most likely of these parts to leak.</p> <p>The different valve types include gate, globe, butterfly, ball and plug. The first two types are a rising-stem design, and the rest are quarter-turn valves. Valves may either be equipped with a hand-wheel or lever for manual operations, or an actuator or motor for automated operation.</p>
Vent and Flare Systems	Venting and flaring are common methods of disposing of waste gas volumes at oil and natural gas facilities. The stacks are designed to provide safe atmospheric dispersion of the effluent. Flares are normally used where the waste gas contains odorous or toxic components (e.g., hydrogen sulphide). Otherwise the gas is usually vented. Typically, separate flare/vent systems are used for high- and low-pressure waste gas streams.
Venting	The release of waste gases to the atmosphere by design or operational practice. This may occur on either a continuous or intermittent basis. The most common causes or sources of these emissions are pneumatic devices that use natural gas as the supply medium (e.g., compressor starter motors, chemical injection and odourization pumps, instrument control loops, valve actuators, and some types of glycol circulation pumps), equipment blowdowns and purging activities, and venting of still-column off-gas by glycol dehydrators.
Volatile Organic	Any compound of carbon, excluding carbon monoxide, and carbon dioxide, which participates in

Term	Definition
Compounds (VOC)	atmospheric chemical reactions. This excludes methane, ethane, methylene chloride, methyl chloroform, acetone, many fluorocarbons, and certain classes of per fluorocarbons.
Waste Gas	Any gas that leaks into the environment or is vented or flared.
Waste Water Injection Facility	Facility constructed and operated for the purpose of moving waste produced water (brine) into a petroleum reservoir.
Water Storage	Tankage used to store produced water at oil and natural gas production and processing facilities prior to being transported to a disposal or re-injection facility.
Water Treatment Facility	A facility for removing suspended and dissolved solids and salts prior to being used to generate steam.
Well	A hole drilled in the earth for the purpose of (1) finding or producing crude oil or natural gas; or (2) providing services related to the production of crude oil or natural gas.
Well Drilling	The process of boring a hole from the surface to a potential producing zone in an oil or natural gas reservoir. Diesel engines are typically used to power the drilling mechanism.
Well Drill-Stem Test	When the target zone has been reached in the drilling of an oil or natural gas well, a drill-stem test may be performed to determine the production potential of the zone. This test occurs when the drilling rig is on the well. During a test, the zone is produced through the centre of the drill-stem. At the surface, the gas and liquid phases are separated and measured. If it is a sour well, the gas phase is flared; otherwise, the gas may be vented to the atmosphere.
Well Servicing (or Workover)	Work performed on a well after its initial completion to repair downhole equipment or to increase production rates.
Well Testing	Flow testing conducted to determine the deliverability of a well. (Sometimes the test may be conducted into a flow or gathering line; however, more often the liquids are produced into temporary tankage brought on site for the test, and the gas phase is either vented or flared.).
Wellhead	The equipment fitted to the top of a well casing to maintain surface control of the well (i.e., outlets, valves, blowout preventers, etc).
Wellsite Facilities	The facilities located at an oil or natural gas well site. These may include separation and metering, line heaters, chemical injection, compression or pumping facilities, dehydration, or storage for produced liquids.
Wet Natural Gas	Field natural gas that needs to be processed to extract natural gas liquids in order to meet contract hydrocarbon dew point requirements.

6 APPENDIX - ECONOMIC EVALUATION METHODOLOGY

A rigorous economic analysis is performed for each applicable control technology considered for a particular emissions reduction opportunity. The objective of the evaluation is to determine the practicality of each option and help determine the best choice for the given application. All economic values are given in US dollars (USD) unless otherwise stated.

Other factors, beyond feasibility, that may affect a final decision include, but are not limited to:

- Net environmental impacts of the project (i.e., both in terms of total GHG emissions and local air quality impacts).
- Impacts on the facility reliability and work-place safety.
- Benefits to the local economy.
- Site-specific constraints that may adversely affect the ability to implement the technology. These constraints could, for example, include excessive footprint requirement compared to the space available, inadequate capacity of the existing utilities to accommodate the incremental loads of the technology and excessive unaccounted for costs to upgrade the utility system, excessive distances and routing challenges to run the necessary piping and utility services required by the technology, lack of adequately skilled local labour pools to operate and maintain the technology, limited capital resources, etc.

The final ranking of opportunities and control options needs to consider the evaluation criteria of management or the financiers being approached. Generally, energy conservation and environmental projects only proceed if they are driven by regulatory requirements. In the oil and natural gas industry, environmental or green projects do not, regardless of their profitability, compete effectively against traditional exploration and drilling projects that increase reserves and infrastructure projects that bring new production on line. Increased reserves, increased revenues and overall profitability are the key parameters upon which the market evaluates energy companies. A company's socioeconomic and environmental performance is often only assessed on a qualitative basis and not given meaningful weighting in the evaluation of a project or in the incentive program for management and employees. One of the challenges is the cost of trying to quantifying such parameters in an objective manner. Accordingly, it is expected that identified project opportunities will only proceed through access to green bonds and other non-traditional capital funds specifically dedicated for environmental and energy conservation projects. In these cases, not only is the return on investment a consideration, but so also is the amount of GHG emission reductions achieved and secondary benefits

such as local air quality improvements, conservation of a non-renewable resource and socio-economic factors such as job creation and stimulation of the local economy.

The key outputs of the economic analysis are the cash commitments and revenues produced (or costs avoided) in each year of operation, the net present value of the project, the return on investment, and the payback period. The detailed results of each economic analysis completed are presented in the results section of the appendix, herein, relating to the specific waste gas recovery, emissions management or energy efficiency opportunity being considered.

The analysis is truncated at the end of the specified project life or at the point where the operating costs exceed the financial benefits being achieved. Details of the calculations performed, key assumptions and the applied level of rigor are delineated in the following subsections. All calculations are performed using *CSimOnline*.

The primary input information required for the economic analysis includes the following:

- Capital and operating costs.
- Relevant interest rates, discount rates and taxes (including emission taxes).
- Site-specific production decline over the life of the project.
- Energy demands and commodity pricing.
- Decommissioning costs and salvage values.

6.1 COST ESTIMATING

6.1.1 CAPITAL COSTS

The capital costs of a given, fully-installed and commissioned, control option are estimated using one of the following two approaches, depending on the circumstances and the time and resources available for the evaluation:

- Method 1: Determination on a per-unit throughput basis, according to the scale of the application and recent pricing for comparable sized and types of systems in Canada. The throughput requirements are determined based on the relevant measured and reported activity for the application (e.g., gas flow and oil production).
- Method 2: Determination based on a semi-detailed assessment of the major equipment, materials, labour, and services needed to design, procure, construct and commission the control measure, and recent or budgetary pricing obtained

from vendors and service providers. The major equipment or process packages (e.g., compressors, line heaters, aerial coolers, refrigeration systems, etc.), as well as any piping systems or pipeline sections, are sized based on rigorous process simulations and sizing calculations performed using *CSimOnline*. A preliminary material take-off (e.g., instrumentation, valves, piping, pumps, vessels, heat exchangers, etc.), is developed based on typical piping and instrumentation diagrams (P&ID) for the control measure and supplemental estimates by a senior cost estimator or engineer. Additional material needs (e.g., valves, piping, structural, steel, piles, cement), trades and services (e.g., welders, pipe fitters, laborers, etc.), onsite-supervision, engineering and drafting are estimated by a senior cost estimator or engineer based on experience and/or typical cost breakdowns from other similar projects.

Method 1 is classified as a Class 5 cost estimate based on the estimate classification system developed by American Associate of Cost Engineers (AACE) International and summarized in Table 9 below. The AACE suggested contingency for this estimate class is 50% and the results are deemed to be suitable for concept screening. The second approach is equivalent to a Class 4 or Class 3 estimate, depending on the quality and detail of the information available for the simulation and sizing calculations. The corresponding AACE suggested contingency for these estimates is 30% or 20%, respectively, and the results are deemed to be suitable for at least the study of feasibility and potentially even for budget authorization or control. The actual method applied can be determined by viewing the detailed economic analysis results for each case (i.e., which are located in the results section of the appendix dealing with the type of opportunity being considered such as vents and flares, compressors, steam systems, etc.).

Table 9: Estimate classification system as applied in engineering, procurement and construction for the process industries.				
Estimate Class	Project Stage	Methodology	Expected Accuracy	Suggested Contingency
Class 5	Concept Screening	<ul style="list-style-type: none"> • Capacity Factored • Parametric Models • Judgement • Analogy 	L: -20% to -50% H: +30% to +100%	50%
Class 4	Study of Feasibility	<ul style="list-style-type: none"> • Equipment Factored • Parametric Models 	L: -15% to -30% H: +20% to +50%	30%
Class 3	Budget Authorization or Control	• Semi-Detailed Unit Costs with Assembly Level Line Items.	L: -10% to -20% H: +10% to +30%	20%
Class 2	Control or Bid/Tender	• Detailed Unit Costs with Forced Detailed Take-off	L: -5% to -15% H: +5% to +20%	15%

Table 9: Estimate classification system as applied in engineering, procurement and construction for the process industries.				
Estimate Class	Project Stage	Methodology	Expected Accuracy	Suggested Contingency
Class 1	Check Estimate or Bid/Tender	<ul style="list-style-type: none"> Detailed Unit Costs with Detailed Take-off 	L: -3% to -10% H: +3% to +15%	5%

Source: AACE RP No. 18R-97.

Normal practice is to express the capital costs on a before-tax basis and exclude overhead costs. In regulatory applications, it may also be required that contingency costs be excluded. Contingencies are not applied herein unless otherwise stated in the capital cost breakdown provided in the economic analysis results.

Capital costs may include the following major expense categories:

- Public consultation and regulatory approvals.
- Additional surface lease or right-of-way.
- Engineering, procurement and project-management services.
- Equipment and materials (including structural steel).
- Freight.
- Construction services.
- Installation of utility services (e.g., electric power, fuel gas, water, telecommunications, and roadways).
- Inspection and commissioning services.

Structural steel is required for aboveground piping systems, equipment bases, access platforms, stairs and handrails. Some structural work may be done at fabrication shops and then shipped to the site for reduced costs. Typical company specifications require all structural steel work to be sandblasted, primed and painted.

The construction services may be further disaggregated into the following subcategories:

- Labour: Labour hours are directly related to the quantities of materials. The relative efficiency of labour depends on the availability of skilled craftsmen and the relative site conditions. Weather conditions may also be important if significant outside work is planned. Remote sites or areas with infrequent workloads may have problems maintaining a reasonable number and selection of qualified crafts people. If adequate numbers of skilled people are not available locally, training is an option if the project is large enough; or else craftsmen can

be imported from other locations. Subsistence and travel pay usually is required when importing crafts people.

- Excavation/Civil: Soil conditions and the required depth of any underground systems may have a significant impact on costs. Compaction is also more difficult to achieve in certain situations and this increases the hours needed for backfill operations. Other matters to consider are the presence of rock, high water tables, poor soil conditions requiring removal, availability of import fill, site access for equipment, degree of hand excavation or backfill required, and constraints on pile driving due to close proximity of sensitive operating equipment and buried piping.
- Concrete: Foundation costs can be substantial. If piling is required, then the cost of the concrete for pile caps is less than for a spread footing type foundation but the combined cost of piling and pile caps is usually higher. The depth of foundation needed to avoid frost lines (where applicable) is also a factor that can increase the amount of concrete required. Designing for earthquake zones increases the size of the foundations, rebar and anchor bolts and can add 20 to 30 percent to concrete costs. Additionally, soil and environmental conditions which attack concrete may require special mixes of concrete costing more and special coating or treatment of rebar and anchor bolts. Pouring and curing of concrete may require expensive heating and hoarding if done during severe winter conditions.

Winterization requirements (where applicable) can drive up costs if heat tracing or additional shelters are required.

The applicability and relative contribution of each expense category to total costs depends on the type of control technology being considered and the specific application. The costs of any equipment (such as emergency flares) that would also be required in the absence of the proposed control technology are excluded from the assessed capital cost.

In assessing the capital costs for each technology it is assumed, for simplicity, that the costs are incurred all in the first year. This may be true for low-capital-cost options, but for more capital-intensive options, the cost would normally be incurred in phases over several years to help minimize risks. In many applications, the total capital cost of a control technology is substantially greater than the direct costs of the basic uninstalled control device. For example, the uninstalled end control device (e.g., an incinerator) for a large-scale vapour collection and control application may represent less than 10 percent of the capital cost for the total installed system. Thus, it is important to account for all ancillary system, installation and other requirements needed to implement a safe, operable and reliable solution.

Where one control device may service a number of different sources at a site (such as a vapour collection and control system), only a single appropriately-sized unit is priced.

6.1.2 R&D COSTS

Some emerging and embryonic control technologies may be assessed a research and development cost. For simplicity, where these costs occur it is assumed that they are all incurred in the first year; however, they would normally be incurred over a much longer period of time (e.g., 5 to 10 years).

6.1.3 OPERATING COSTS

The operating costs for a technology may include the following items:

- Energy (fuel or electricity) consumption.
- Chemical consumption.
- Inspection, servicing and repairs (i.e., including parts, materials, and labour).
- Process operators and their associated overhead (i.e., including training, supervision and administration).
- Monitoring and third-party verification of emission reductions being achieved.
- Environmental reporting.
- Lease payments.
- Royalty payments.
- Insurance premiums.
- Other expenses (e.g., vehicles, subsistence, etc.) associated with operating and maintaining a control measure or device.

Currently, for most technologies, only energy and chemical consumption costs are assessed, which tend to be the dominant operating costs. The only exception is for technologies comprising the implementation of improved operating procedures and formal directed inspection and maintenance (DI&M) programs to manage fugitive losses of hydrocarbons or steam. The costs of improved operating procedures are assessed based on the increased labour and, possibly, training requirements; while any instrumentation or software needs would be assessed as a capital cost.

Operating cost estimates for DI&M programs are developed based on estimated component populations, per-component inspection costs, typical leak frequencies and per-component repair or replacement costs by type of component.

The amount and type of energy and chemical consumption required by a technology is determined based on the types of equipment or process units involved (e.g., pump,

compressor, heater, boiler, refrigeration system, etc.), rigorous simulations of the process and modelling of the system losses (e.g., friction effects and heat losses). The typical efficiency of the devices involved is accounted for, and detailed engineering calculations are performed to estimate secondary energy demands such as the power requirements of fans.

Current commodity pricing for fuel, electricity and chemicals is applied to the assessed energy and chemical requirements where these commodities are purchased from third parties. Where electricity is produced on site, the costs are evaluated based on the cost of the fuel requirements by the power generator. Electricity purchased from the utility grid may include both an energy and a demand charge. The existence of demand charges may adversely affect the economics of simply reducing a facilities base load.

A direct commodity price of zero is applied to fuel gas in the following situations:

- The fuel gas is withdrawn from a waste stream.
- The fuel is extracted from the process, and there are no direct costs or penalties payable for doing so (e.g., royalties).
- The process gas is owned by others (e.g., the producer or shipper), but the facility operator is given a shrinkage allowance to account for fuel use and system losses (e.g., station and unit blowdowns, compressor starts, fugitive equipment leaks, etc.), and there are no rewards to the facility operator for achieving better than the allowable shrinkage limit.

A non-zero price for fuel gas is only assigned where it is directly derived from a purchased energy input stream.

Fuel gas that is assigned a zero commodity price may have an indirect value, depending on the net impact its use has on a facility's product sales and purchased energy inputs. This impact is assessed for a given control measure by performing detailed mass and energy balances for the before (baseline) and after cases.

If changes in the amount of fuel gas withdrawn from the process do not increase product sales or reduce purchased energy inputs (e.g., due to system bottlenecks), but help to reduce production at the wellhead, then the applied measure extends the life of the reservoir. This benefit is not fully realized until the economic end of the reservoir's life and, therefore, is assigned a zero value for simplification purposes.

6.1.4 REMOVAL COSTS

Removal costs are separate from installation costs and apply where a process unit must be removed and replaced by an alternative unit (e.g., removing gas-operated pumps and replacing them with electric-powered units).

6.1.5 DECOMMISSIONING COSTS AND SALVAGE VALUE

Currently, decommissioning costs are assumed to be negligible and the salvage value of a control technology at the end of the project life is assumed to be zero. This is likely a conservative position for projects that have a life expectancy of less than 10 years; especially, where the control technology can be installed as a skid-mounted solution that may be easily reused at other locations.

Where a salvage value is assessed, it is included as project revenue in the year the value would be realized. The salvage value is assessed as the reasonable market value of the equipment and not simply a depreciated value from a taxation perspective.

6.2 DETERMINATION OF COSTS AVOIDED AND REVENUES PRODUCED

Avoided or reduced costs are treated as a positive source of revenue for the purpose of the economic analysis. Avoided costs may result from energy efficiency and waste gas utilization measures that reduced purchased fuel or electric power consumption. They may also include avoided or reduced emission taxes, where applicable.

Positive revenue also results from increased product sales, either at the facility where the control measure is implemented, or at downstream facilities that may benefit from the measure (such as a gas processing plant or petroleum refinery). Products may include natural gas, ethane, liquefied petroleum gas (LPG) (i.e., propane and butane), condensate (e.g., pentanes and heavier hydrocarbons), crude oil, hydrogen, refined products (e.g., diesel, gasoline, naphtha, gas oil, synthetic crude oil, lubricants, and chemicals), and even electricity and low-pressure ((LP) or high-pressure (HP) steam.

Avoided product or commodity losses and increases in product sales achieved through capture and production of waste gas streams and reduced fuel withdrawals from the process are all classified as conserved product and assessed an economic value. The value of the product depends on the type of product and where in the system it is conserved, the quality of the conserved product, and the applicable regulatory and contract incentives.

Generally, the value of natural gas decreases in moving upstream due to increasing treating, processing and transport requirements.

6.2.1 COMMODITY PRICING

The applied commodity pricing is given in the detailed economic analysis results of the control option being evaluated. These results are presented in the results section of the appendix dealing with the type of opportunity being considered (such as vents and flares, compressors, steam systems, etc.).

Natural gas is normally priced on a calorific basis (e.g., in \$/GJ). If the natural gas contains non-methane hydrocarbons, then this increases the specific calorific value of the gas and, consequently, its price on a volumetric basis. If the natural gas is rich in condensable hydrocarbons, such as LPGs and Pentanes Plus, then much greater value may be realized for the gas by first processing it to extract these fractions and marketing them separately from the remaining residue gas (i.e., mostly methane and ethane). This increased value typically occurs regardless of whether the LPG and Pentanes Plus is extracted and marketed at the facility where the control measure is installed, or where the actual extraction and sale or benefit of the LPGs and Pentanes Plus occurs at a downstream facility such as a gas processing plant or petroleum refinery. Extracting and marketing the LPGs and Pentanes Plus separately can easily double the total value realized, even after accounting for processing costs.

In this report, the application of calorific pricing is deemed to give the lower economic value of natural gas. The higher economic value of the natural gas is determined by applying calorific pricing to the residue gas fraction and appropriate commodity pricing to the LPG, Pentanes Plus and other fractions. If the final disposition of the natural gas is simply use as fuel without any preprocessing to recovery of the LPG and Pentanes Plus fractions, then the lower pricing is applied to the natural gas. If the gas is pre-processed to recover the LPG and Pentanes Plus fractions before it is used or sold as fuel, then the higher natural gas pricing is applied, even if the processing occurs at a downstream facility (e.g., at a gas processing plant).

Overall, the actual value of avoided hydrocarbon losses is very site-specific and depends on many factors. Some important considerations are listed below:

- Cost to find, develop, produce, treat/upgrade/process/refine, and deliver the sales product,

- Parts of the system where emission reductions are achieved; for instance, gas conserved before processing is less valuable than gas conserved after processing.
- Impact of emission reductions on specific energy consumption, equipment life, workplace safety, operability, reliability and deliverability.
- Supply and Demand Constraints (Conserved gas may become reserve production that is not sold until the reservoir and market conditions change to the point where demand exceeds supplied; this time lag reduces the present value of such gas.)
- Market prices and current contract requirements.
- Government taxes and royalties.

6.2.1.1 DETERMINATION OF THE HIGHER ECONOMIC VALUE OF AN ENERGY STREAM

The higher economic value of an energy stream is assessed using the following relation:

$$V_{Higher} = (Q_{V_{CH_4}} \cdot p_{CH_4} + Q_{L_{LPG}} \cdot p_{LPG} + Q_{L_{C_5+}} \cdot p_{C_5+} + Q_{H_2} \cdot p_{H_2} + e \cdot p_e) \cdot g_c$$

Equation 1

Where,

V	=	value of a stream (USD/y)
p	=	commodity price (USD/unit of flow measure)
e	=	electric power consumption (kW·h)
g _c	=	constant of proportionality
	=	365 d/y

The subscripts CH₄, LPG, C₅₊, H₂ and e denote methane, liquefied petroleum gas, Pentanes Plus, hydrogen and electricity, respectively, and the subscripts V and L denote vapour and liquid, respectively.

Equation 1 is applicable where the energy either has or will be fractionated into its different commodity constituents so that the full market value of these constituents can be realized.

6.2.1.2 DETERMINATION OF THE LOWER ECONOMIC VALUE OF AN ENERGY STREAM

The lower value of an energy stream occurs when the stream is simply used for fuel in a combustion source without first extracting any of the more valuable commodities present

in the stream. In such cases, the value of the stream is assessed based on its calorific value and the pricing of natural gas expressed on a calorific basis.

$$V_{Lower} = Q_V \cdot p_{CH4}$$

Equation 2

6.2.2 DETERMINATION OF THE NET OPERATING COST

The net operating cost is determined by the following relation:

$$NOC = OC + OCS$$

Equation 3

Where,

- NOC = Net operating costs (USD/y)
- OC = Operating cost of the considered control technology (USD). For the purposes of these calculations, the operating cost is assumed to remain constant; however, these costs would tend to increase with time due to increasing maintenance needs as infrastructure ages and the accumulated effects of wear and tear need to be addressed.
- OCS = Operating and maintenance savings from discontinued use of the replaced system (USD/y)

Typically, the incremental annual operating costs for a gas conservation project, including gas gathering and processing fees, may be assumed to be up to 10 per cent of the initial capital cost of installing the conservation facilities. If the gas contains 10 moles per kilomole (mol/kmol) hydrogen sulphide (H₂S) or more, the incremental annual operating costs for the project may be assumed to be up to 20 per cent of the capital cost to initially install the conservation facilities.

6.2.3 EMISSION TAXES AND TRADABLE PERMITS

Some jurisdictions impose taxes on emissions of certain pollutants; this is usually expressed in terms of USD per tonne of pollutant emitted. Examples of pollutant emissions that may be taxed include SO₂, NO_x, VOC and CO₂. Where CO₂ emissions are taxed this is referred to as a carbon tax. If a Cap and Trade program exists, then emission

reductions achieved below an operators allowance may be registered and marketed as emission reduction credits.

Reductions in the amount of emission tax paid, or the generation of marketable emission reduction credits (ERCs), as a result of applying emission control measures is treated as a source of revenues. If the control technology actually increases the emissions of a taxable pollutant then this is treated as negative revenue (or an operating cost).

These revenues are assessed based on the rules or laws of the applicable jurisdiction.

6.3 PROJECT LIFE

The life of a given control option is application dependent and tied directly to the remaining economic life of the associated wells or upstream facilities. Traditionally, new oil and gas developments have been assessed based on a 20-year life expectancy. As the industry ages; however, the quality of finds in a given sedimentary basin gradually declines leading to reduced life expectancies for new projects. As well, average remaining life of existing facilities is declining. In some parts of the industry, such as heavy oil and shallow gas production, the average economic life of wells has always been relatively low. A typical heavy oil well may only have 2 to 4 years of economic life through application of primary production techniques and an additional 4 to 6 years with subsequent application of enhanced recovery techniques.

6.4 FINANCIAL RATES

6.4.1 DISCOUNT RATE

The discount rate and opportunity cost of equity in the upstream petroleum industry is usually taken to be a value in the range of 6 to 12 percent, depending on the segment of the industry. Typically, the discount rate increases in moving upstream through the industry in accordance with increasing financial risks. The actual value applied herein is declared in the sections where it is used and is shown in the results of the completed economic evaluations.

Most oil and gas ventures are expected to yield better than bank interest to compensate for the added risk involved. Typically, a non-redeemable guaranteed interest certificate (GIC) yields a 3.900 to 4.450 percent rate of return for a 1-year term, and a 5.150 percent return for a 10-year GIC. In comparison, the prime interest rate might be 6.250 percent.

6.4.2 OTHER DISCOUNT RATES

In addition to the overall financial discount rate, further discount factors may be applied to the relevant cost and revenue accounts for each control option to account for the applicable taxes, tax shields and royalties.

6.4.3 INFLATION RATES

An average inflation rate may be assumed for the time series.

6.5 ECONOMIC ANALYSIS

6.5.1 NET PRESENT VALUE (NPV)

The net present value of an investment is assessed using the following relation:

$$NPV = -CC + SV_{RE} + \frac{SV_{CE}}{(1+i)^N} + \sum_{n=1}^{n=N} \frac{((V_{Losses} \cdot \eta - OC + OCS))}{(1+i)^n}$$

Equation 4

Where,

- n = a variable indicating the number of years since the start of the project (y),
- N = life expectancy of the project or life expectancy of the control technology, whichever is less (y).
- i = discount rate (expressed as a fractional value).
- V_{Losses} = value of avoidable product losses or energy consumption (USD/y). For the purposes of these calculations, the value of the product losses is assumed to remain constant with time, but would actually tend to increase due to inflation and supply and demand considerations. Also, the costs of any required processing have not been considered in assessing the value of the product losses (these costs are assumed to be small).
- η = Control efficiency of the considered control technology (dimensionless fractional value).
- OC = Operating cost of the considered control technology (USD). For the purposes of these calculations, the operating cost is assumed to remain constant; however, these would tend to increase with time due to inflation.
- OCS = Operating and maintenance savings from discontinued use of the replaced System (USD/y)
- CC = Capital cost of the considered control technology (USD).
- SV_{RE} = Net salvage value of any equipment removed when the control technology

SV_{CE} = is installed (USD).
 Net salvage value of the control equipment at the end of the project life or at the end of the life of the control technology, whichever occurs first (USD).

6.5.2 RETURN ON INVESTMENT (ROI)

The return on investment (ROI) is determined using the following relation:

(1)

$$ROI = \frac{(V_{Losses} \cdot \eta - OC + OCS)}{CC - SV_{RE}} \cdot 100\%$$

Equation 5

Where,

V_{Losses} = Value of avoidable product losses or energy consumption (USD/y).
 η = Efficiency of the selected control measure in reducing product losses and avoidable fuel consumption (fractional dimensionless value).
 OC = Operating cost of the considered control technology (USD).
 CC = Capital cost of the considered control technology (USD).

6.5.3 PAYBACK PERIOD

The payback period is determined using the following relation:

$$PP = \frac{CC - SV_{RE}}{V_{Losses} \cdot \eta - OC + OCS}$$

Equation 6

6.6 PRODUCTION DECLINE RATES

A production decline curve analysis is derived from empirical observations of the production performance of oil and gas wells. Three types of decline have been observed historically: exponential, hyperbolic, and harmonic.

Decline curves represent production from the reservoir under "boundary dominated flow" conditions. This means that during the early life of a well, while it is still in "transient flow" and the reservoir boundaries have not been reached, decline curves should NOT be expected to be applicable. Typically, during transient flow, the decline rate is high, but it stabilizes once boundary dominated flow is reached. For most wells this happens within a few months of production. However, for low permeability wells (tight gas wells, in particular) transient flow conditions can last several years, and strictly speaking, should not be analyzed by decline curve methods until after they have reached stabilization.

The generalized relation used to predict production decline rates for oil and natural gas wells is:

$$\frac{dQ}{dt} = -DQ^{(b+1)}$$

Equation 7

Where,

- D = Decline as a fraction of production rate;
- Q = Production rate at time t .
- b = Constant (dimensionless) that varies from 0 to 1.

Decline analysis is valid when the recovery mechanism and the operating conditions do not vary with time. Single-phase liquid production, high-pressure gas, tubing-restricted gas production, and poor waterflood performance lead to $b = 0$ (Fetkovich). Under solution gas drive, the lower the gas relative permeability, the smaller is the quantity of gas produced; hence the decline in reservoir pressure is slower, and accordingly the decline rate is lower (higher value of b). Simulation studies for a range of gas and oil relative permeability values have indicated $0.1 < b < 0.4$, with the average resulting in $b = 0.3$. Above the bubble point pressure, $b = 0$ (exponential decline), while below the bubble point b increases for solution gas drive. Typical gas wells have b in the range of 0.4 to 0.5. Conventional (light oil) reservoirs under edge water drive (effective water drive) seem to exhibit $b = 0.5$.

If there is a mechanism present that maintains reservoir pressure, the production rate would essentially remain constant (under constant producing pressure) and the decline would tend towards zero. Examples of such mechanisms could be gas or water injection, an active water drive, or gas-cap drive. Since the decline in reservoir pressure is small, the production driving force remains large, and the decline in the producing rate is correspondingly smaller. For such cases, there is no theoretical reason why the decline coefficient could not be greater than one. Much later in the life of these reservoirs, when the oil column thins, the production rate would decline exponentially and hydrocarbon production is replaced by water.

Situations where values of $b > 1$ occur are as follows:

- The interpretation of the available production data is wrong.
- The data is still in transient flow and has not reached “boundary-dominated flow”.
- Reservoir layering is occurring.
- Some fractured gas wells have values of $b > 1$ (and sometimes as high as 3.5).

The exponential solution occurs when $b = 0$ and is given by the following relation:

$$Q(t) = Q_i e^{-D_i t}$$

Equation 8

Where

- D_i = Initial decline.
 Q_i = Initial production rate.
 $Q(t)$ = Production rate at time t .
 t = Time.

For exponential decline the decline rate, D , is constant. If D varies, the decline is considered to be either hyperbolic or harmonic, in which case, an exponent “ b ” is incorporated into the equation of the decline curve, to account for the changing decline rate.

The hyperbolic solutions are given by the following relation:

$$Q(t) = Q_i (1 + b D_i t)^{-\frac{1}{b}}, \text{ for } 0 < b \leq 1$$

Equation 9

Harmonic decline is a special case of hyperbolic decline, with $b = 1$, i.e., the decline rate, D , is proportional to q and the above equation simplifies to:

$$Q(t) = \frac{Q_i}{(1 + Dt)}$$

Equation 10

This means that the decline rate, D , goes to zero when Q approaches zero. This type of performance is expected when very effective recovery mechanisms such as gravity drainage are active. Another example of harmonic decline is the production of high viscosity oil driven by encroaching edge-water. Due to unfavourable mobility ratio, early water breakthrough occurs and the bulk of the oil production will be obtained at high water cuts. If the total fluid rate is kept constant then the increasing amount of water in the total fluid will cause the oil production to decline. This decline in oil rate may follow a harmonic decline.

6.7 REFERENCES CITED

American Associate of Cost Engineers (AACE) International. 2011. 18R-97: Cost Estimate Classification System: As Applied in Engineering, Procurement, and Construction for the Process Industries.

6.8 RESULTS

The results of each economic analysis performed, including all input information used in the analysis, are provided in the results section of the Appendix dealing with the given waste gas recovery, energy management or fugitive emissions management opportunity.

7 APPENDIX - TECHNICAL & ENVIRONMENTAL ANALYSIS METHODOLOGY

The technical, economic (see *APPENDIX – Economic Evaluations*), and environmental evaluations that have been performed as part of this study were all done using *CSimOnline*; a proprietary multi-lingual web-based tool for evaluating cost-effective opportunities to reduce atmospheric emissions and improve energy efficiencies at oil, natural gas, petroleum, and petrochemical facilities. The program allows users to:

- Baseline an opportunity against performance benchmarks reflecting good industry practice and regulatory compliance (i.e., quantify avoidable inefficiencies and wastage or losses).
- Predict time-series changes in production using appropriate decline models fitted to historical production accounting data for the facility, and assess the impact of these changes on the economic life of a project and the net impacts and benefits achieved.
- Efficiently conduct a rigorous time-series evaluation of the different control options applicable to a given opportunity, while giving consideration to any site-specific constraints and circumstances specified by the user.
- Perform a preliminary design of each control option, including sizing of equipment and determining the optimum operating conditions, energy input requirements, and benefits achieved,
- Assess the net impact on GHG and criteria air contaminant (i.e., SO₂, NO_x, CO, VOC, and PM) emissions over the project life based on both direct and indirect contributions.
- Determine the necessary capital and operating expenditures, overall economics, and best solution for the given opportunity.

The program can be used to perform screening-level evaluations through to developing sufficiently detailed business cases for consideration by senior management and potential financiers in seeking authorization for expenditures (AFEs) and approvals to proceed. The results may be reported on either a named or anonymous basis (i.e., for internal and public release, respectively).

7.1 TECHNICAL EVALUATION

7.1.1 INPUT DATA MANAGEMENT AND TRANSPARENCY

The source, time, date and basis of all input data and the reference and date of all critical library information (e.g., emissions factors, vendor data, etc.) is tracked for auditability, transparency and easy updating.

Where the project team has performed measurements, the unique asset identification number (AIN) of each measurement device used is recorded along with the measurement results. Through the AIN, information is available from Clearstone's asset management system regarding the type, make, model and serial number of the device. Additionally, the AIN allows retrieval of the instrument's service records and the calibration results for the time period during which it was used. Clearstone's asset management system programmatically tracks the servicing schedule for each devices and issues early notification of approaching due dates.

7.1.1.1 QUALITY CONTROL AND QUALITY ASSURANCE MEASURES

Clearstone's quality management system establishes guidelines for performing functional checks, calibration checks, calibrations and servicing of equipment, and programmatically tracks and issues alerts when servicing and calibrations due dates are approaching. All servicing and calibration records are maintained electronically in a data management system.

Most types of calibrations are performed at Clearstone's laboratory using properly maintained and certified commercial calibration systems; these include: pressure calibrators, temperature calibrators, gas calibration standards and dilution systems for calibration of gas sensors and analyzers, a commercial wind tunnel equipped with a laser Doppler anemometer for calibration of gas flow meters and velocity probes, and multifunction calibrators for calibration of industrial process instrumentation and control systems.

Additionally, all chargeable instrument batteries are tested on a regular schedule to confirm that they are able to hold a proper charge and can be relied upon during field assignments; faulty batteries are replaced as needed.

7.1.2 PROCESS SIMULATIONS

CSimOnline features an integrated flowsheet simulator and pipe flow model. Both applications comprise a shared thermodynamic engine (“*ThermoEngine*”) and fluid properties package. The flowsheet simulator is used to model process systems and support rigorous engineering calculations to design and size equipment and system components. The pipe flow model determines pressure and heat losses in piping for single and two-phase flow, and is used to determine compression, pumping, insulation and heating requirements, as well as optimal pipe sizes.

7.1.2.1 FLOWSHEET SIMULATOR

The flowsheet simulator invokes predefined flowsheet models (comprised of stream and unit operations) of process equipment packages and systems, and then simulates their behavior for a variety of potential purposes including: performance benchmarking, equipment sizing, determination of optimum operating conditions and prediction of critical parameters (e.g., energy and cooling loads, product flows and quality, bi-product flows, etc.). Where optimizations are performed, the flowsheet model is run in an iterative loop featuring a convergence algorithm and objective function applicable to the given application.

All calculations have been implemented in a manner that minimizes user expertise and setup requirements.

7.1.2.2 THERMODYNAMIC ENGINE

ThermoEngine is a utility program, which uses equations of state (EOS) to predict thermodynamic properties (e.g., density, enthalpy, entropy, Gibbs free energy, heat capacity, compressibility factors, heating value, dew point, bubble point, sound speed, etc.) and phase behavior of both pure (or single-component) and multi-component chemicals systems. *ThermoEngine* features routines for determining sing-phase, two-phase and multi-phase equilibria, including vapour-liquid (VL), liquid-liquid (LL), TEG-hydrocarbon, EG-hydrocarbon, water-hydrocarbon and EG-water-hydrocarbon equilibria, and hydrate formation.

The types of chemical systems *ThermoEngine* accommodates, and the applied equations of state are summarized in Table 10. The types of practical applications *ThermoEngine* is applied to include natural gas production and processing, oil production, steam systems, refrigeration systems, and, to a limited extent, petrochemical and petroleum refining.

Table 10: Equations of state implemented in *ThermoEngine* and the target chemical systems to which they are applied.

Chemical System	Sub Category	Equation of State	Reference
Hydrocarbon	All	Peng-Robinson (PR)	Peng and Robinson (1976)
Aqueous Glycol	All	Twu, Sim and Tassone (TST)	(Twu et. al., 2002)
Water and Steam	All	LAPWS	IAPWS (2002)
Hydrocarbon Refrigerants	Methane	Setzmann and Wagner	Setzmann and Wagner. (1991)
	Ethane	Booker and Wagner	Booker and Wagner (2006)
	Propane	Miyamoto and Watanabe	Miyamoto and Watanabe (2000)
	n-Butane	Miyamoto and Watanabe	Miyamoto and Watanabe (2001)
	Iso-Butane	Miyamoto and Watanabe	Miyamoto and Watanabe (2002)
Fluorocarbon Refrigerants	R32	Tillner-Roth and Baehr	Tillner-Roth and Baehr (1994)
	R134A	Tillner-Roth and Yokozeki	Tillner-Roth and Yokozeki (1997)
Ammonia	All	Haar-Gallagher (HG)	Haar and Gallagher (1978)
Carbon Dioxide	All	Span-Wagner (SW)	Span and Wagner (1996)

7.1.2.3 FLUID PROPERTY PREDICTION

The fluid properties package is used to determine the following rheological properties of fluids:

- Vapour pressure.
- Dynamic viscosity.
- Kinematic viscosity.
- Thermal conductivity.
- Surface tension.

7.1.2.4 PIPELINE SIMULATIONS

The pipe flow model simulates fluid flow, pressure losses and heat losses in pipe networks. Specific features and capabilities of the program include the following:

- Compressible and incompressible fluids.
- Single-phase and two-phase fluid flow (Beggs and Brill, 1973).
- Built-in expressions for Darcy friction factors covering the entire flow regime including laminar, transition and turbulent flow.

- A wide range of relative surface roughness values and library of standard pipe diameters and wall thicknesses.
- Consideration of bends, contractions, expansions, T-junctions, and valves using a library of standard loss coefficients.
- Consideration of pumps, compressors, fans, blowers and line heaters.

7.1.3 EQUIPMENT SIZING

Sizing algorithms, based largely on applicable GPSA and API guidelines, have been implemented for most common equipment types including the following:

- Aerial Coolers.
- Compressors (i.e., reciprocating, centrifugal, screw and rotary vane).
- Engines (i.e., reciprocating, micro-turbine and turbine).
- Emulsion treaters.
- Flame arrestors.
- Flares (i.e., unassisted, air-assist, and steam assist).
- Gas sweetening plant.
- Heat exchangers.
- Hydrate control systems (i.e., line heaters, methanol injection, ethylene glycol injection, TEG dehydrators).
- Pressure and vacuum relief devices.
- Piping (i.e., process piping and pipeline segments).
- Process heaters and boilers.
- Pumps (i.e., positive displacement and velocity).
- Refrigeration and condenser systems (i.e., Joule-Thompson, conventional shallow-cut, conventional deep-cut, micro-condensers, mini-LNG plants, mid to large-sized LNG plants).
- Separators and scrubbers.

The calculations draw on libraries of standard size selections (e.g., for pipe diameter and wall thickness, compressors frames and cylinders, engines, finned tubing, etc.) and consider parasitic or secondary loads and energy demands such as cooler fans. Stress calculations and corrosion considerations are performed in determining pipe and vessel thickness requirements. Typical piping and instrumentation diagrams are used to develop preliminary material take-offs, where warranted, for items such as instrumentation, block valves, control valves, pressure relief devices, strainers, secondary pumps, etc.

7.1.4 EQUIPMENT PERFORMANCE BENCHMARKING

For most types of performance benchmarking, calculations are performed to assess avoidable or correctable departures from typical manufacturer's recommended operating conditions, regulatory standards, industry best practices and, in the absence of such criteria, average emission factors. The impacts of these departures on emissions, operating costs and product sales are assessed.

Also potentially evaluated are the impacts of fuel switching, load management (i.e., to operate at high-efficiency portions of equipment performance curves), minimizing purge gas requirements, upgrading to high-efficiency (or low-emitting) and high-reliability components.

A work flow diagram depicting the analysis and benchmarking of a process unit or system is presented in Figure 5.

7.1.5 EVALUATION OF CONTROL TECHNOLOGIES

A work flow diagram depicting the evaluation of control technologies is presented in Figure 6.

7.2 ENVIRONMENTAL EVALUATIONS

The environmental evaluations are limited to assessing the net changes in atmospheric emissions over the life of a project due to the implementation of a target control technology or measure. Both direct and indirect emission contributions are assessed. Indirect emissions are attributed to the use of fossil-fuel generated electric power where the power is purchased from the electric utility grid or a third party. If the electric power is generated on site then this is deemed to be a direct source of emissions and any and incremental increases in fuel consumption, and corresponding atmospheric emissions, by the power generator needed to meet the electric power demands of a control technology are assessed.

The emissions from a given source are assessed based on activity levels and one of the following methods, presented in the order of decreasing preference:

- Unit or site-specific measurement results.
- Stoichiometric mass balances.
- Manufacturer's emission factors.

- Country-specific emission factors.
- Average emission factors published by U.S. EPA in AP-42 (<http://www3.epa.gov/ttnchie1/ap42/>).
- Other published sources of emission factors.

Activity levels are assessed based on available production accounting data, measurement results and process simulations, and are correct each year over the project life to reflect the predicted production decline rates.

Emissions due to fugitive equipment leaks, where considered, are assessed using one of the following approaches as determined based on the type of information available:

- Published leak frequencies and emission factors are applied to an inventory of equipment components (e.g., valves, connectors, pressure relief valves, pump seals and compressors seals) in the target service category (e.g., hydrocarbon or steam).
- The results of a leak detection and measurement program are applied.

In the case of steam leaks, measured losses are generally determined by evaluating make-up water requirements for the steam system and then correcting for boiler blowdown and accounting for non-recycled steam uses (e.g., steam assist on flare systems). Screening and individual leak measurements could also be applied, but measurements at the individual component level are much more challenging to perform for components in steam service.

7.3 BASIC CSIMONLINE ARCHITECTURE

The user may define one or more facilities for an individual client or company. A single facility has a parent company and is defined in terms of process streams, process units, process systems, fugitive equipment leaks and control technologies.

7.3.1 PROCESS STREAMS

A process stream has the following primary properties: chemical composition, molar flow rate, temperature, and pressure. From this information, a range of secondary properties are determined such as phase behavior, viscosity, enthalpy, entropy, density, etc.

Streams may be associated with a process unit, process system, or subcategory of equipment components to quantify energy inputs and losses, products, byproducts and emissions.

7.3.2 PROCESS UNIT OR MAJOR EQUIPMENT UNIT

A process unit is a major equipment package or a collection of equipment components (e.g., valves, pipe, vessels, pumps, heat exchanges, reboilers, etc.) that function together to perform a particular treating or processing function such as storage of produced liquids (e.g., tanks), transportation of process fluids (e.g., major pumps or compressors), gas dehydration (glycol dehydrators), gas sweetening (amine unit), waste gas disposal (e.g., flares, vents and incinerators), and so on..

7.3.3 PROCESS SYSTEM

A process system is an integrated collection of streams, process packages and major equipment units.

7.3.4 CONTROL TECHNOLOGIES

Control technologies are a proposed add-on piece of equipment or best practice (e.g., more frequent inspection and maintenance) that may be applied to a process unit, process system or fugitive equipment leaks to enhance its environmental performance or energy efficiency. Existing control equipment that is already installed is deemed to be an integral part of a process unit or process system and is considered in evaluating and benchmarking the given process unit or system performance.

7.3.5 FACILITIES

A facility may have multiple streams, process units, process systems and fugitive equipment service categories.

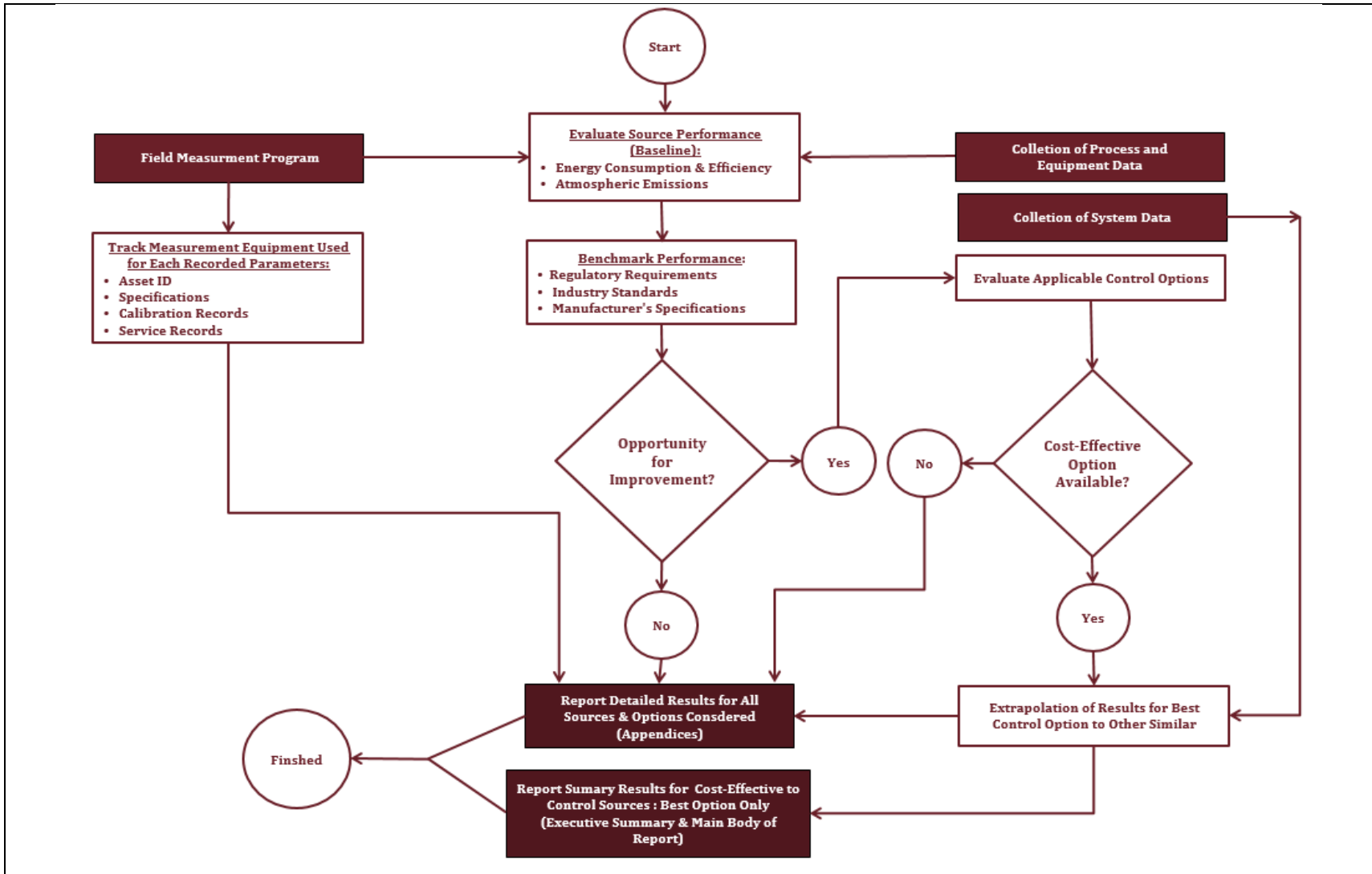

Figure 5: Work flow diagram depicting the basic functionality of CSimOnline.

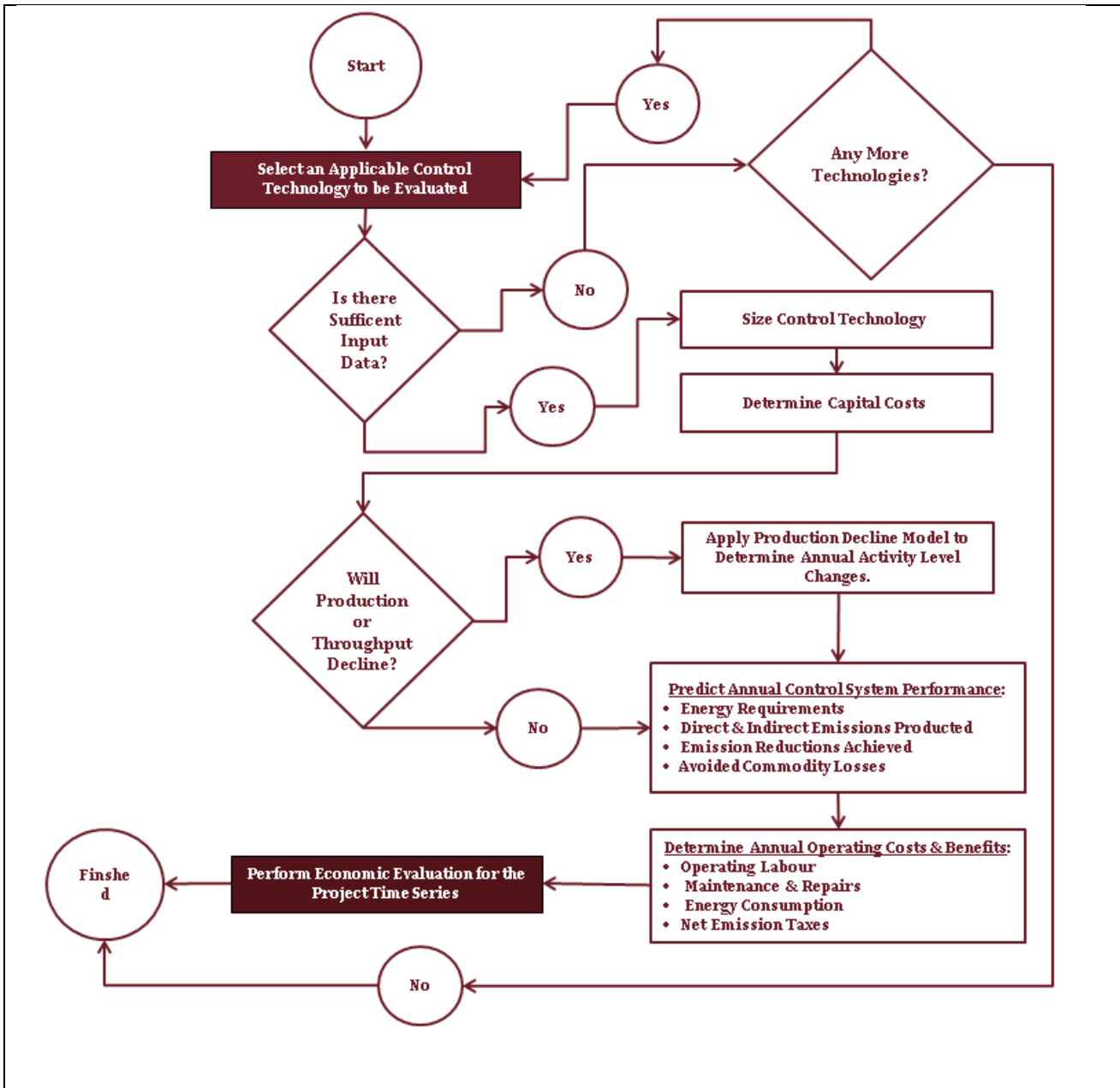

Figure 6: Work flow diagram depicting the control technology selection, sizing and evaluation process.

7.4 REFERENCES CITED

Beggs H.D. and Brill J.P. 1973. A study of the two-phase flow in inclined pipes. *Journal of Petroleum Technology*. May 1973. Pp. 607.

Booker D. and Wagner W. 2006. A Reference Equation of state for the thermodynamic properties of Ethane for temperatures from melting point to 675 °K and pressure up to 900 MPa. *Journal of Physical and Chemical Reference Data*. vol. 35(1). Pp. 205 -266.

Haar L. and Gallagher J.S. 1978. Thermodynamic properties of ammonia. *Journal of Physical and Chemical Reference Data*. vol. 7(3). Pp. 635-792.

Miyamoto H. and Watanabe K. 2000. A thermodynamic property model for Fluid Phase Propane. *International Journal of Thermophysics*. Vol. 21(5), pp. 1045-1072.

Miyamoto H. and Watanabe W., 2001. Thermodynamic property model for fluid phase n-butane. *International journal of Thermophysics*. Vol. 22(2). Pp. 459-475.

Miyamoto H. and Watanabe W., 2002. Thermodynamic property model for fluid phase isobutane. *International journal of Thermophysics*. Vol. 23(2). Pp. 477-499.

Peng, D.Y. and Robinson, D.B., 1976. A new two-constant equation of state: *Industrial and engineering chemistry*, vol. 15, pp. 59–64.

Span R. and Wagner W., 1996. A New Equation of State for Carbon Dioxide Covering the Fluid Region from the Triple-Point Temperature to 1100 K at Pressures up to 800 MPa. *Journal of the Physical and Chemical Reference Data*, vol. 25(6), pp. 1509-1596.

Setzmann U. and Wagner W. 1991. A new Equation of state and Tables of Thermodynamic Properties for Methane Covering the Ranges from the Melting Line to 625K at a pressure up to 1000 MPa. *Journal of Physical and Chemical Reference Data*. vol. 20(6). Pp. 1061 -1155.

Tillner-Roth R. and Baehr H.D. 1994. *Journal of Physical and Chemical Reference Data*. vol. 23(5). Pp. 657 -729.

Tillner-Roth R., Yokozeki A. 1997. An International Standard Equation of State for Difluoromethane (R-32) for Temperatures From the Triple Point at 136.34 °K to 435 °K and Pressures Up To 70 MPa. *Journal of Physical and Chemical Reference Data*. vol. 26(6). Pp. 1273 -1328.

Twu C.H., Sim W.D., and Tassone V., 2002. A versatile liquid activity model for SRK, PR and a new cubic equation-of- state TST. *Fluid Phase Equilibria*, vol. 194-197, pp. 385-399.

U.S. Environmental Protection Agency. 2009. AP-42, Fifth Edition – Compilation of Air Pollutant Emission Factors, Volume 1: Stationary Point and Area Sources. Available at: <http://www3.epa.gov/ttnchie1/ap42/> .

Wagner W. and Pruss A. 2002. The IAPWS Formulation 1995 for the Thermodynamic Properties of Ordinary Water Substance for General and Scientific Use. *Journal of Physical and Chemical Reference Data*. vol. 31(2). Pp. 395-535. Available at www.iapws.org.

8 APPENDIX - FLARE AND VENT SYSTEMS

8.1 INTRODUCTION

Flare and vent systems exist in essentially all segments of the oil and natural gas industry and are used for two basic types of waste gas disposal: intermittent and continuous. Intermittent applications may include the disposal of waste volumes from emergency pressure relief episodes, operator initiated or instrumented depressurization events (e.g., depressurization of process equipment for inspection or maintenance purposes, or depressurization of piping for tie-ins), plant or system upsets, well servicing and testing, pigging events, and routine blowdown of instruments, drip pots and scrubbers. Continuous applications may include disposal of waste associated gas and/or tank vapours at oil production facilities, casing gas at stripper wells and heavy oil wells, process waste or byproduct streams that either have little or no value or are uneconomical to recover (e.g., vent gas from glycol dehydrators, acid gas from gas sweetening units, and sometimes stabilizer overheads), and vent gas from gas-operated devices where natural gas is used as the supply medium (e.g., instrument control loops, chemical injection pumps, samplers, etc.). Typically, waste gas volumes are flared if they pose an odour, health or safety concern, and, otherwise, are vented.

Where waste gas is vented or flared, it is generally either because the gas is deemed to be uneconomical to conserve or insufficient information is available to evaluate the practicability of conserving the gas. As hydrocarbon prices change and conservation technologies improve, practicable opportunities may arise that were previously uneconomical. As well, it may simply be that, when the facility was first commissioned, there was insufficient capital available to even consider conservation of waste gas streams.

The main objective of a typical vent and flare survey is to identify opportunities to achieve significant cost-effective reductions in venting and flaring. Large-scale applications and small to medium-scale applications that are highly replicable across an oil and natural gas system are both important to consider. Where waste gas streams are determined to be uneconomical to conserve, it is preferable that the gas is flared rather than vented to reduce net GHG and air toxic emissions (e.g., benzene, toluene, ethyl benzene and xylene [BTEX], and potentially hydrogen sulphide and other toxic compounds).

Where the gas is flared it is important to ensure that the flaring is reliable and provides good destruction efficiencies as well as smokeless operation. Black smoke or soot poses a potentially significant health risk in the local airshed and is a powerful climate forcer.

Black carbon is a major contributor to the fine particle (PM_{2.5}) burden in the air. It is small enough to be easily inhaled into the lungs and has been associated with adverse health effects. Whether black carbon is itself toxic or functions as an indicator of other co-pollutants is currently under debate (<http://www.epa.gov/research/airscience/air-blackcarbon.htm>). But, clearly, black carbon is associated with asthma, and other respiratory problems, low birth weights, heart attacks and lung cancer.

8.2 FLARE AND VENT GAS FLOW RATE DETERMINATION

When evaluating opportunities for reducing vented and flared volumes, actual site measurements are preferred for completing the economic evaluations and for properly sizing the potential control options. Ideally, time series measurements should be performed to determine the variability in the waste gas flow rate.

If existing vent or flare gas flow meters are in place, then the available flow readings from these devices are used if they are of adequate quality. Otherwise, independent measurements or assessments are performed during the site survey.

The range of measurement techniques that may be considered is delineated in Table 11 below. The actual method applied for each surveyed vent or flare is identified in the detailed analysis results presented at the end of this appendix. The following subsections provide a more detailed discussion of the primary approaches.

Table 11: Summary listing of potential methodologies for determining vent and flare rates.			
Methodology		Applicability	Description
Primary Category	Subcategory		
Installed Flow Meters	---	Vents and Flares	Often no flow meters are installed on vent or flare lines, or there are concerns regarding their reliability. Still, where available, it is always useful to reference the flows indicated by these devices.
End-of-pipe	Flow-through Flow Meter	Vents	Total flow from the end of the pipe is captured and routing through a flow meters suited to the application (e.g., turbine meter, diaphragm meter, transit-time ultrasonic flow meter cell, etc.).
	Velocity Traverse	Vents	A suitable velocity probe is used to measure the flow velocity at selected points across the diameter of the vent outlet, and the results are integrated over the cross-sectional flow area.
	Calibrated Bag	Vents	The flow rate is determined by measuring the time required to fill a durable anti-static plastic bag of known volume.
In-line	Insertion Probe	Vents & Flares	A velocity probe (e.g., micro-tip vane anemometer or optical probe, pitot tube, etc.) is inserted through an available port on the

Table 11: Summary listing of potential methodologies for determining vent and flare rates.

Methodology		Applicability	Description
Primary Category	Subcategory		
			vent or flare line where the total flow can be measured. The probe is used to measure the velocity profile at that location and/or to continuously monitor the flow velocity at a fixed radial position. In the latter case, corrections are made to account for the velocity profile at the selected location. The monitoring port should be at least 5 pipe diameters upstream of any flow disturbance and 15 pipe diameters downstream of any flow disturbance.
	In-line Tracer Test	Vents & Flares	A suitable tracer gas (e.g., acetylene or nitrous oxide) is injected into the flare line at a known rate and the concentration a second location at least 20 pipe diameters downstream is measured. The flare or vent gas flow rate can then be determined based on a simple mass balance that accounts for the amount of tracer dilution that has occurred.
Clamp-on	Transit-time Ultrasonic Flow Meters	Vents & Flares	This technique can only be applied at points where the gas pressure in the flare or vent line is sufficient to allow an ultrasonic signal to be sent through the pipe wall and across the pipe diameter. For most practical applications involving natural gas and steel pipes the pressure needs to be at least 10 bar.
Estimation	Process Simulation	Vents & Flares	If the process operating conditions are known then, for some sources (e.g., storage tanks experiencing flashing losses, glycol dehydrators, etc.), it may be possible to accurately predict the amount of emissions using rigorous process simulators.
	Empirical Correlation	Vents & Flares	This may be possible where vented or flared rates correlate with equipment or process unit activity levels, and the correlations and activity data are available.
	VPAC	Vents & Flares	This technique may only be used to determine the amount of leakage past the seat of vent or flare valves into the vent or flare line. This involves measure the amount of acoustical noise at the valve body and applying a correlation that relates the leak rate to the measurement
	Mass and Energy Balance	Vents & Flares	This approach may often involve determining vent or flare rates by difference between two or more known streams. As well, it may consist of utilizing gas-to-oil ratio (GOR) data and current oil production rates.
	System Design Value	Vents & Flares	In the absence of better data, it may sometimes be necessary to assess vent or flare rates based on a facility's or process unit's

Table 11: Summary listing of potential methodologies for determining vent and flare rates.

Methodology		Applicability	Description
Primary Category	Subcategory		
			initial design basis.
	Engineering Judgment	Vents	This may involve observing the source using a leak-imaging camera and estimating the amount of venting based on known vent rates for other sources with similar characteristics.
	Flame-length Technique	Flares	An empirical correlation is used to estimate the flaring rate based on the flame length, flare gas heating value and the flare tip diameter. The flame length is determined optically. The method only applies there is no flame lift-off from the flare tip occurring. If lift-off is occurring the method may significantly understate the amount of flaring.

8.2.1 INSTALLED FLOW METERS

Flare meters are excellent diagnostic tools which can be used to identify excessive purge rates and/or leakage into the flare system that might otherwise go unnoticed, as well as quantify total intermittent and continuous flared volumes Pilot, purge, enriching and assist gas should be metered independently wherever possible.

Alberta Energy Regulator (AER) recommends the use of flare meters at larger oil and natural gas batteries, pipeline facilities and gas processing plants where there are multiple connections to the flare system, even when the aforementioned average flaring rate is not exceeded (AER, 2013; <http://www.aer.ca/documents/directives/Directive017.pdf>). Similar requirements exist in many other jurisdictions. At a minimum, sufficient fittings should be installed to facilitate periodic checking of the residual flare rate if continuous flare metering is not required or deemed necessary. Flare streams are particularly challenging to meter because of the potentially large variability in flow and composition.

Generally, flare meters should be gas-composition independent and exhibit accuracy over a high turndown range (i.e. 1:100 or better). Ultrasonic flow meters are the preferred choice in most permanent vent or flare applications involving wet and dirty gas, provided the liquid content does not exceed about 0.5 percent by volume. Ultrasonic flow meters offer excellent rangeability (2000:1), low uncertainties (± 2 to 5 percent of value), do not require frequent calibration, are composition independent (i.e., corrections for the composition of the gas are not required) and they do not pose any significant flow restriction (i.e., the transducers are only wetted to the flow and are not extended into the

flow as depicted in Figure 7). If greater amounts of liquids are anticipated then a liquids knockout system should be installed immediately upstream of the flow meter. Orifice and venturi meters may be considered instead of ultrasonic flow meters in applications involving stable wet or dirty flows; they can tolerate the presence of more liquids but have the disadvantages of greatly reduced rangeability (5:1) and the need for frequent calibrations, especially if the gas composition is variable. If properly maintained and calibrated, they provide uncertainties of ± 2 to 4 percent of full scale readings.

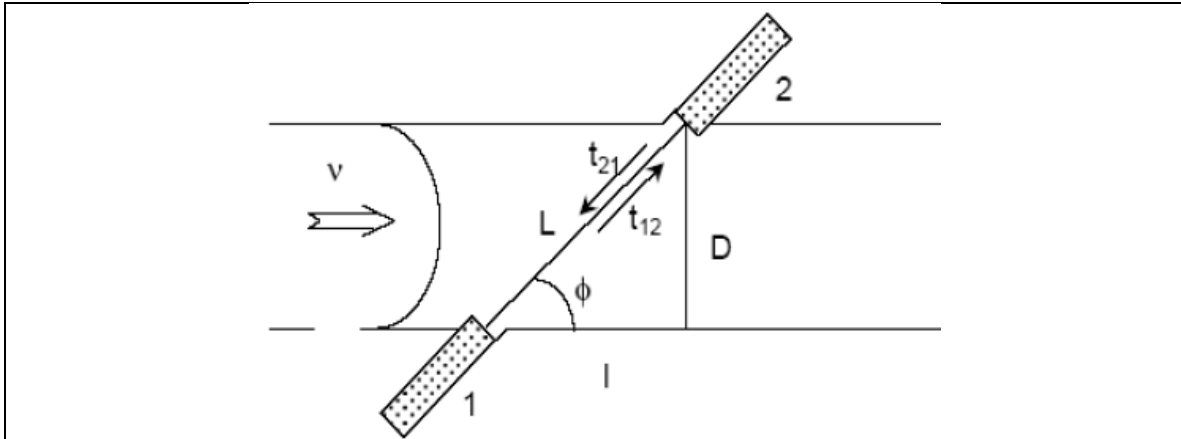

Figure 7: Schematic diagram depicting a pair of ultrasonic flow transducers wetted to the flow in a pipe.

Optical flow meters may also be considered. They are a more recent flare gas measurement technology and there is little published experience on the use of these flow meters. The optical flow meter measures flow velocity based on the transit time of naturally occurring particles in the flow stream over a short known path length. The rangeability of optical flow meters is 2000:1 and the uncertainty of the measurements is ± 2.5 to 7 percent of value. The optical flow meter is reportedly suitable for moderately wet or dirty fluids. Still, limited experience with this technology indicates it can be temperamental. A particular advantage of the technology is that it comprises a single measurement probe that is easy to install (see Figure 8).



Figure 8: Photograph of an optical flow meter probe.

The use of thermal anemometers in flare gas flow measurement applications is generally not practical as they are highly composition dependent, are susceptible to fouling and cannot tolerate the presence of any liquids of condensation.

8.2.2 INDEPENDENT FLOW MEASUREMENTS

If no flare metering is in place or the results available from those meters are of questionable accuracy, then the flare rate is measured using one of two basic techniques: a portable velocity probe or by conducting an inline tracer test. If suitable ports for these measurements are unavailable, then the flaring rate is estimated using an empirical flame-length technique (see the next section).

8.2.2.1 VELOCITY PROBE

Most portable velocity probes can be inserted into the flare piping through a NPS $\frac{3}{4}$ full port valve. The port needs to be located downstream of all tie-ins on a straight section of pipe, and, where possible, should be at least 15 pipe-diameters downstream and 5 pipe-diameters upstream of any flow disturbances.

Where this approach is applied, typically, an optical flow meter manufactured by Photon Control is used. The instrument readings are continuously data logged at 1 Hz for a sufficient period of time to characterize the flow variations.

This meter uses the “laser-two-focus” or L2F method, which measures the light scattering signal from two laser beams created by small particles in the gas stream. Using the time difference between the two signals and the known physical distance separating them, an accurate physical measurement of the velocity is made. The result is then correct to standard conditions based on the temperature and pressure of the flare gas at the measurement point.

The meter can measure flow rates from 0.1 to 150 m/s, over a temperature range of -30 to +150 °C and pressures up to 690 kPa, with an uncertainty of 2.5% within the range of 1 to 100 m/s. The calibration of the meter is verified in-house both prior to and upon return from the measurement campaign. The velocity measurements are performed at a fixed radial position in the pipe.

The velocity readings at the fixed radial measurement position are adjusted to the average area-weighted flow velocity across the entire cross-sectional flow area using empirical correlations provided by the manufacturer. This correction is somewhat composition dependent as it is expressed as a function of the Reynolds number, though the physical velocity measurement is not.

A preferred approach to using the correlation is to conduct a velocity traverse to determine the actual velocity profile. The velocity traverse consists of measuring the velocity profile across the pipe diameter using a micro-tip vane anemometer. Ideally, this is done immediately before and after the monitoring period. The two profiles are then used to determine an average factor to convert flow velocities at the fixed radial position of the optical flow meter to the average area-weighted flow velocity across the pipe diameter.

For a given radial measurement position (or node), the discrete flow area to which the reading is applied is determined using the following equation:

$$A_i = \frac{\pi}{2} \cdot \left[\left(\frac{r_{i+1} + r_i}{2} \right)^2 - \left(\frac{r_i + r_{i-1}}{2} \right)^2 \right]$$

Equation 11

Where,

A_i = discrete cross-sectional flow area to which the velocity at position i is

applied (m²). Since the velocity measurements were performed on both sides of the pipe centre, each discrete area is applied to only a 180° arc (i.e., $\pi/2$ radians). The discrete areas are not symmetrical because the radial measurement positions are not symmetrical about the pipe centre.

- r_i = radial position of measurement point (or node) i (m).
 r_{i+1} = radial position of the next outer measurement point (or node), i + 1, (m).
 r_{i-1} = radial position of the next inner measurement point, i - 1, (m).

If the monitoring point i is the last node before the pipe wall then the value of $\frac{r_{i+1}+r_i}{2}$ in Equation 11 is set to, R, the inside radius of the pipe in Equation 11.

If the monitoring point i is the first node out from either side of the pipe centre then the value of $\frac{r_i+r_{i-1}}{2}$ in Equation 11 is set to zero.

The area-weighted average flow velocity is determined using the following equation:

$$\bar{V}(t) = \frac{\sum_{i=1}^{i=N_R} V_{i,t} \cdot A_i}{\pi R^2}$$

Equation 12

Where,

- $\sum A_i$ = total cross-sectional flow area (m²)
 = πR^2
 $\bar{V}(t)$ = area-weighted average flow velocity at time t (m/s).
 $V_{i,t}$ = instantaneous flow velocity measured at radial position i at time t (m/s).
 R = Inside radius of the pipe (m).
 N_R = number of radial positions across the pipe diameter at which velocity measurements were performed.

The flow velocity at a given radial position is related to the average area-weighted flow velocity using the k-factor which is determined using the following relation:

$$k_{r,j} = \frac{\bar{V}_j}{V_{r,j}}$$

Equation 13

Where,

- $k_{r,j}$ = k-factor, determined based on velocity profile j, for application in converting a flow velocity reading at a given radial position r to the average area-weighted flow velocity (dimensionless).

- \bar{V}_j = average area-weighted flow velocity determined based on measured velocity profile j (m/s).
- $V_{r,j}$ = measured flow velocity at radial position r based on the measured velocity profile j (m/s).

8.2.2.2 INLINE TRACER TEST

In the absence of reliable installed flow meters, the flow rate of waste gas to a flare may be readily measured using an inline tracer technique. This method involves injecting small amounts of a tracer gas into the flare line at a constant and accurately measured rate, and then continuously sampling and analyzing the flare gas at a suitable downstream port where the tracer gas and flare gas have become well mixed. The flare gas flow rate is back-calculated based on a mass balance involving the known tracer gas injection rate and the observed amount of tracer gas dilution at the downstream sampling and analysis point. This is done using the following relation:

$$Q_F = \left(\frac{1 - (y_T - y_{T_o}) \cdot g_{c1}}{(y_T - y_{T_o}) \cdot g_{c1}} \right) \cdot Q_T \cdot g_{c2}$$

Equation 14

Where,

- Q_F = flare gas flow rate (Sm³/h).
- Q_T = tracer gas injection rate (SL/min).
- y_T = tracer gas concentration in the sampled flare gas during the tracer test (ppm).
- y_{T_o} = background concentration of tracer gas in the flare gas prior to starting the tracer gas inject (ppm).
- g_{c1} = constant of proportionality
= 10⁻⁶ ppm⁻¹ · mole fraction
- g_{c2} = constant of proportionality
= 60 x 10⁻³ m³ · L⁻¹ · min · h⁻¹

The key advantages of this method are:

- It is generally much easier and safer to apply than other measurement techniques. The necessary ports for tracer gas injection and downstream flare gas sampling are often either already available or easily installed (e.g., at pressure gauges and

other suitable fittings on flare knock-out drums, drain ports on flame arrestors, purge gas injection points, etc). In the absence of any suitable injection and sampling ports these would have to be installed in advance using hot tap techniques or other appropriate methods. In comparison, there are much greater constraints on the positioning, orientation and size requirements for a port suitable for flow rate determinations using an insertion-style velocity probe. The application of other potential flow measurement technologies such as orifice meters and ultrasonic flow meters would be even more costly and challenging to install.

- Flare rates of a few m³/h to hundreds of thousands of m³/h can be measured with accuracies of ±5% and better.
- The results are not affected by the composition of the flare gas. As well, the method is tolerant of the presence of some condensation and there is no need for any temperature or pressure corrections (i.e., the injection data and analysis are already corrected to standard conditions).
- Acetylene has proved to be a convenient tracer gas. It is inexpensive, readily available, only needs to be injected in small amounts (e.g., 0.010 to 5.0 L/min) and is not naturally occurring in waste gas streams at upstream oil and natural gas facilities.
- The flare gas flow rates can be measured at monitoring rates of up to 1 Hz thereby offering high-resolution, nearly-continuous, real-time flow rate monitoring. The results may be displayed graphically in real time.

The following sections delineate the measurement requirements.

Injection and Sampling Ports

The tracer gas is injected through ¼” tubing using a high-accuracy mass flow controller. The flare gas at the downstream port is sampled using ¼” tubing and an intrinsically safe sampling pump or line pressure (if it is high enough). Accordingly, the fittings available at each point are reduced to ¼” tubing connections.

For turbulent flow, the minimum required axial mixing distance between the tracer gas injection and sampling points is 10 pipe diameters; although a separation distance of at least 20 pipe diameters is preferred. The tracer injection point may be located on a branch flare line or purge gas line; however, the sampling is done from the main flare trunk line downstream of the last branch flare line contributing to the total flare gas flow rate if that is the rate which is to be determined.

Tracer Gas Injection System

The acetylene pressure regulator produces an output acetylene pressure of 5 to 15 psi (35 to 105 kPa) greater than the process pressure at the injection point. A typical acetylene cylinder will have a pressure of 250 psig (1725 kPag) when it is full and a standard acetylene pressure regulator will reduce the pressure to a maximum of 15 psig (105 kPag). Thus, if the process pressure is greater than 15 psig (105 kPag), then a non-standard pressure regulator is used.

The mass flow controller cannot be subjected to a pressure differential of more than 15 psi (105 kPa) or a maximum supply pressure of greater than 150 psig (1050 kPag).

Tracer Gas Sampling and Analysis System

The concentration of acetylene in the sampled flare is continuously measured at a rate of 1 Hz using a high-precision ultraportable cavity ringdown spectrometer with an operating range of 0.002 to 100 ppm of acetylene. The tracer gas injection rate and downstream concentration is continuously logged and a graphical trend analysis of the readings is provided in real time using a custom data-capture and display system.

Electrical Power

A local source of 115 VAC power will be needed to power all analyzers and a field laptop. If a source of this power is conveniently available then this is used; otherwise, a portable 1500 Watt power inverter is temporarily installed on an automobile to provide the required electrical power. In the latter case, it is necessary to get the vehicle close to the injection point (i.e., ideally within 15 to 20 m of the injection point).

8.2.2.3 FLOW ESTIMATION BASED ON FLARE FLAME LENGTH

If direct flow measurements cannot be performed then the flare rate is estimated using an empirical flame-length correlation derived by Gas Processors Suppliers Association (GPSA) from data provided in the flame-length versus heat-release-rate graphs presented in the American Petroleum Institute's (API's) Recommended Practice (RP) 521. The correlation applies to flare with simple tip designs and can be expected, where the gas composition is well known, to provide accuracies in the range of ± 10 to 60% (i.e., based in the scatter in the available data). The better accuracies tend to occur at the higher flow rates. The correlation is applicable to turbulent diffusion flames for simple flare tip designs up to the point where flame lift-off from the flare tip starts to occur, and for greater flows, underestimates the actual flare rate.

The primary advantage of the method is that it is easy and safe to apply, and it provides a reasonable initial estimate of the flaring rate which makes it useful as a screening technique.

GPSA correlates the flame length L_f and the energy (equivalent) flare flow rate Q (W) of the flare gas stream using the following relation:

$$L_f = 2.14(Q \times 10^{-6})^{0.474}$$

Equation 15

The flame length is determined by photographing the flare tip (see Figure 9), and then scaling up the stack diameter D_p and flame length, L_p , dimensions measured from the photograph to match the actual stack diameter, D_f . This is done using the following relation:

$$L_f = \frac{L_p}{D_p} D_f$$

Equation 16

The flame from each flare is photographed using a Canon EOS 60D SLR digital camera equipped with a 200 mm zoom lens. Multiple images are taken of each flare to fully characterize the range of natural fluctuations in the flame size. The fluctuations in the flame length can be appreciable, even when the flow rate is constant. The flare rate correlates best with the average determined flame length.

The stack outside diameter is determined by back-calculation from the measured stack circumference and confirmed against standard pipe sizes.

The calorific value of the flare gas is determined based on typical gas analyses provided by the facility operators or based on flare gas samples collected and analyzed during the site survey.

With the flame length L_f known, the GPSA correlation is applied to back-calculate the flow rate of the flare gas.

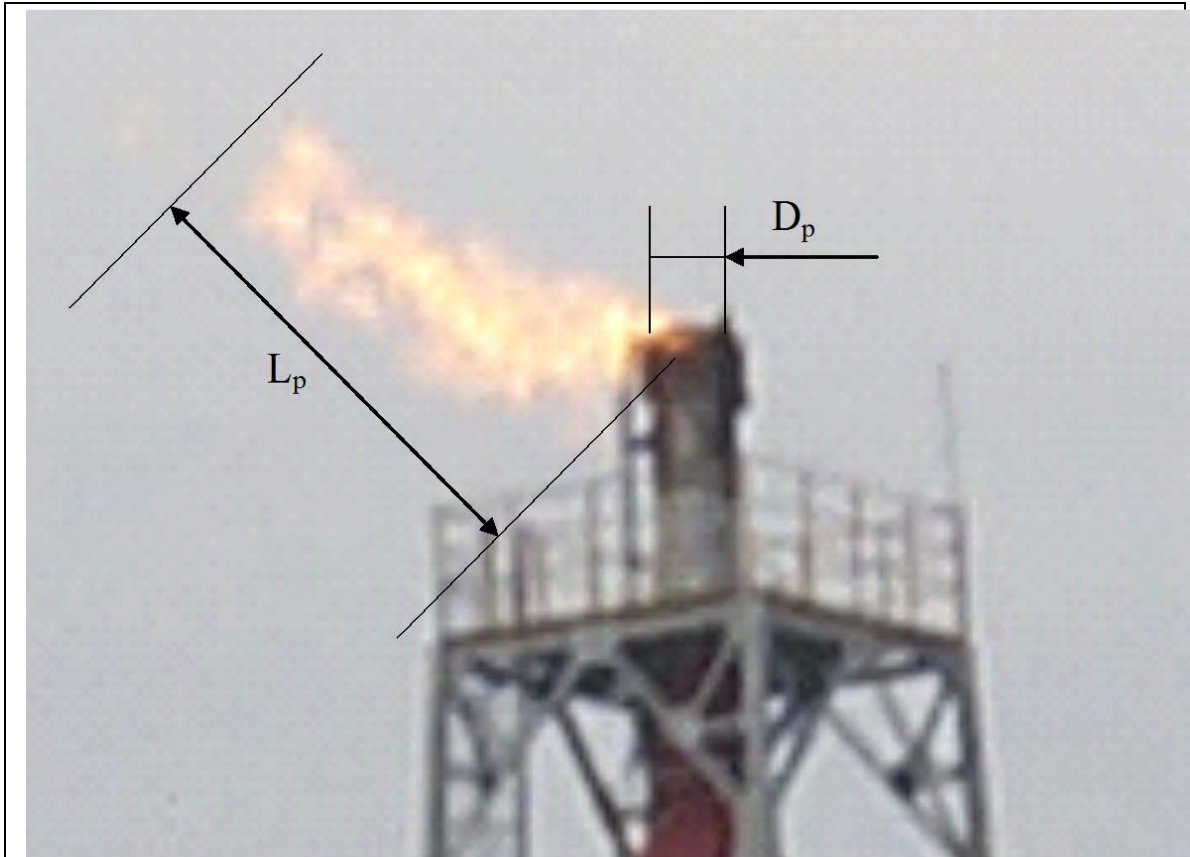

Figure 9: A photograph of one flare flame showing the related dimensions for the flame length approach.

8.3 FLARE AND VENT GAS ANALYSIS

Analyzing the waste gas to determine its composition is an important component of the survey. Typically, a portable natural gas analyzer is taken to the field to perform the analyses on site. Where this is not practical to do, gas composition data available from the facility or typical compositions for the type of operation are used.

Where the analyses are performed in the field a portable optical gas chromatograph is used. The selected instrument provides a C₁ to C₅₊ hydrocarbon analysis as well as quantify CO₂ and H₂S concentrations.

8.4 FLARE OPTIMIZATION

The design of a flare must consider the following:

- range of waste gas flows to be handled,
- waste gas composition, temperature and pressure,

- heat release rates,
- minimum required destruction efficiency,
- impact of the emissions at ground level and at downwind receptors, and
- potential for liquids to be contained or formed in the waste gas being sent to the flare.

Specific design features that affect flare performance include the discharge nozzle (or burner tip) design, the ignition system, the purge gas system and, if applicable, the enriching gas and assist gas systems. A review of each flare design and features is conducted to determine if there is a potential to reduce energy consumption, recover the flare gas and improve the flare performance.

The following sections delineate the methodology used to quantify and evaluate opportunities to minimize, where applicable, the amount of pilot, purge and make-up gas consumption, as well as to improve the destruction efficiency and reliability of flares where flare gas reduction is not practicable.

8.4.1 MANAGEMENT OF FUEL CONSUMPTION BY FLARES

8.4.1.1 PURGE GAS CONSUMPTION

Metered or estimated purge gas flow rates are compared to best management practice (BMP) values. The purge rate can be estimated where residual flows include purge gas and leakage into the flare header, and do not include any contributions due to emergency or planned depressurization events.

The minimum required pure rate depends on the type of seal used, stack diameter, properties of the purge gas and ambient and system conditions.

An opportunity may exist to reduce fuel consumed by continuously purged flare systems by installing purge reduction seals, using instrumentation to control purge rates, switching to an inert gas purge and/or reducing purge rates in response to leakage into the flare system. When evaluating purge gas reductions the purge rate required to maintain a safe stack condition (i.e. prevent air ingress) should be considered in conjunction with purge requirements to prevent burn back and provide adequate header sweep.

Purge reduction seals reduce the purge velocity required to avoid air infiltration into the flare stack and can lead to a significant reductions in the amount of purge gas

consumption, especially on larger diameter stacks. These devices should be considered in most situations where flare systems are continuously purged.

The minimum purge rate required to avoid unsafe air ingress into the stack is not only a function of the stack diameter and purge gas composition, but is dependent on changes in ambient temperature, pressure, wind speed and temperature of products in the flare header. To compensate for the dynamic nature of these dependencies, continuous purge rates are often set above the minimum value required for the conditions under which the flare usually operates. An alternative to specifying an excessive purge rate is to use instrumentation to monitor critical parameters in the flare system (e.g. oxygen concentration, temperature, etc.) and automatically adjust the purge rate to maintain a safe stack condition. The reliability, regular calibration and preventive maintenance of instrumented purge gas control systems are critical to their success.

Leakage into the flare system can be difficult to identify and sometimes necessitates a plant shutdown to correct. During the time it takes to find and repair a leaking component, all or part of the losses can be mitigated by using the leak as a purge source and reducing the supply of purge gas up to the volume of the leak rate.

Some sources of leakage into a flare system are easy to detect because they are audible or cause condensation or ice formation on the outside of the leaking valve. However, many leakage sources are difficult to detect, even with thermal imaging cameras. A technology that has proven to be very effective in detecting leak flare gas valves is the [VPAC](#), an acoustical leak detector manufactured by Mistras Group, which provides both leak detect and quantification capabilities. The amount of leakage is quantified by inputting the numeric acoustical reading from the [VPAC](#) into an empirical correlation along with information concerning the fluid, valve type and size and the pressure difference across the valve. This technology was originally developed in cooperation with BP and is most widely used at petroleum refineries, but it is also suitable for detecting leaking flare valves at upstream oil and natural gas facilities as well.

8.4.1.2 DETERMINATION OF MINIMUM PURGE GAS REQUIREMENTS

For plain-end flares, the purge gas required to avoid unsafe air infiltration can be estimated using the Husa purge model. (CAPP 2008) Equation 17 is an adaptation of the Husa purge model that can be used to estimate minimum purge gas requirements for flare systems:

$$Q = -\ln\left(\frac{O_2 \%}{21}\right) \frac{KD^{3.46}}{L_s} \left[1 - 0.75\left(\frac{MW}{28.96}\right)^{1.5}\right]$$

Equation 17

Where:

- Q is the purge gas consumption in m³/h;
- K is 5.26×10^{-8} ;
- D is the internal diameter of the stack in mm;
- $O_2\%$ is the acceptable oxygen concentration at L_s in % (note: 6% is usually acceptable);
- L_s is the distance into the stack where the safe condition is met in m (note: the lesser of 7.62 m or 10 stack diameters is usually acceptable);
- MW is the molecular weight of the purge gas (19.5 is typical for raw natural gas).

Larger flares are often equipped with seals, which reduce the continuous purge rate required to avoid unsafe air infiltration into the stack. Purge reduction seals do not physically isolate the stack from the surrounding atmosphere. Instead, they utilize proprietary internals, either baffle-type or labyrinth-type, to reduce the ability for buoyant movement of air into the stack. Equation 18 can be used to estimate typical purge requirements for flare systems outfitted with baffle-type seals and Equation 19 can be used to estimate the typical purge gas consumption associated with labyrinth-type seals. Actual purge rates will depend on the seal design and should be obtained from the manufacturer. For baffle-type purge reduction tips (assuming an average purge velocity of 0.0122 m/s), the following relation may be applied to estimate purge gas requirements:

$$Q = 3.447 \times 10^{-5} D^2$$

Equation 18

Where:

- Q is the purge gas consumption in m³/h;
- D is the internal diameter of the stack in mm;

For labyrinth-type purge reduction tips (assuming an average purge velocity of 0.0030 m/s), the following relations may be applied:

$$Q = 8.618 \times 10^{-6} D^2$$

Equation 19

Where:

- Q is the purge gas consumption in m³/h;
- D is the internal diameter of the stack in mm;

Assuming: the average required purge velocity for flares equipped with labyrinth-type purge reduction tips is 0.0030 m/s.

Table 12 presents typical minimum required purge gas rates for different sizes of flares equipped with different types of seals (CAPP 2008).

Table 12: Typical minimum purge rates to avoid unsafe air infiltration.			
Flare Diameter (NPS)¹	Purge Gas Consumption Rate (m³/h)		
	Plain End²	Baffle Type Seal	Labyrinth Type Seal
2	0.07	0.09	0.02
3	0.17	0.21	0.05
4	0.34	0.36	0.09
6	0.93	0.82	0.20
8	1.83	1.42	0.35
10	3.19	2.23	0.56
12	4.98	3.20	0.80
14	6.35	3.90	0.98
16	8.98	5.17	1.29
18	12.16	6.62	1.65
20	15.92	8.24	2.06
24	25.34	12.02	3.01
26	31.04	14.18	3.54
30	44.57	19.03	4.76
36	82.87	27.63	6.91
42	142.76	37.84	9.46
48	228.39	49.65	12.41
54	345.39	63.06	15.77
60	499.74	78.07	19.52

¹ Standard wall pipe

8.4.2 PILOT GAS CONSUMPTION

Many flares are outfitted with continuously burning gas pilots to ensure ignition of the flared gases or liquids. The number and type of pilots required depends on the flare size, stream composition and wind conditions. Typical pilot requirements and fuel consumption rates are summarized in Table 13. These rates assume an average pilot fuel consumption rate of 1.98 m³/h/pilot which is reasonable for energy-efficient pilots fueled by sales-quality natural gas (U.S. EPA 2000); however, the actual consumption rate will depend on the burner design and fuel properties. The average fuel requirement of the pilot in Table 2 is multiplied by a safety factor of 2 to estimate the reasonable pilot fuel consumption rate for the flare.

Flare Tip Diameter		Number of Pilot Burners	Average Pilot Gas Consumption	
Inches	Mm		m ³ /h	m ³ /d
1-10	25.4-254	1	1.98	47.52
12-24	304.8-609.6	2	3.96 ¹	95.04 ¹
30-60	762-1524	3	5.95	142.80
>60	>1524	4	7.93	190.32

¹ Adapted from CAPP (2008). The value of average pilot gas consumption for 12 to 24 NPS flares is reported as 3.63 m³/h in the original CAPP document. The correct value is 3.96 m³/h based on the fuel consumption rate of 70 scf/h/pilot in the original source reference of USEPA (2000).

8.4.3 MAKE-UP GAS CONSUMPTION

Make-up fuel is sometimes required to raise the calorific value of flared waste gas to levels that will support stable and efficient combustion.

Equation 20 can be used to estimate minimum make-up gas requirements (CAPP 2008).

$$Q_m = Q_w \frac{LHV_r - LHV_w}{LHV_m - LHV_r}$$

Equation 20

Where:

- Q_m is the make-up fuel gas flow rate (m³/h),
- Q_w is the waste gas flow rate (m³/h),
- LHV_r is the required combined net heating value (i.e. 20 MJ/m³),
- LHV_m is the lower heating value of the make-up gas (MJ/m³),
- LHV_w is the net heating value of the waste gas (MJ/m³).

The quantity of fuel gas used to raise the calorific value of waste gas streams can be reduced by using incinerators in place of flares or by installing instrumentation to automatically adjust the delivery of make-up gas.

8.4.4 MANAGEMENT OF FLARE RELIABILITY AND DESTRUCTION EFFICIENCY

8.4.4.1 MINIMUM ENERGY CONTENT OF COMBINED FLARE VOLUME

The minimum energy content of flared gas is an important performance consideration; the minimum requirements are typically specified by regulatory agencies.

AER (2013; <http://www.aer.ca/documents/directives/DraftDirective060.pdf>) Directive 060 requires the combined net heating value (i.e. lower heating value) of flared gases and make-up fuel to meet or exceed 20 MJ/m³ except for existing flares with a history of stable operation and emergency flare systems in sour gas plants where the heating value may be as low as 12 MJ/m³.

8.4.4.2 FLARE EFFICIENCY

For a typical flare, the efficiency improves as the exit velocity and heating value of the gas increase, and then decrease when soot formation (black smoke) and/or lift-off of the flame from the flare tip start to occur. A quantitative estimate of the flaring efficiency, where no flame lift-off is occurring, may be evaluated based on the following approach:

- Any aerosols that form in the flare gas between the flare knock-out drum and the flare tip is assumed to either pass through the flame zone unburned or to form soot. The amount of aerosol formation is estimated by determining the temperature of the flare knockout drum and assuming the gas at the flare tip is at ambient temperature. The formation of aerosols tends to reduce the heating value and exit velocity of the remaining gas phase since the aerosols are comprised mainly of the higher-molecular weight hydrocarbons.
- The combustion efficiency of the gas phase is assumed to be characterized by the flaring efficiency model published by Johnson *et al.* (1999). That model presents the flaring efficiency as a function of the stack diameter, exit velocity, flare gas heating value and the local wind speed, and was developed based on extensive wind tunnel tests on bench scale and full-scale flares.

The approach taken in Johnson's research project was to experimentally study scaled-down, generic pipe flares under well-controlled conditions to understand the performance of flares in general. To provide control over the wind, research was conducted in a closed-loop wind tunnel where the wind speed from a known direction could be set and the level of turbulence could be prescribed.

A methodology was developed to accurately determine the efficiencies of flares where the combustion products are predominantly gaseous. For a flare burning a mixture of hydrocarbon fuels, the efficiency is described by the "carbon conversion efficiency," which is the effectiveness of the flare in converting the carbon in the fuel to carbon in CO₂.

8.4.4.2.1 CALORIFIC CORRECTION

For a stream with a lower heating value ($LHV < 30 \text{ MJ/m}^3$), the following relation applies:

$$(1 - \eta)(LHV_{mass})^3 = 146.5 \exp\{0.1745 \cdot U_\infty / [(gV_j)^{1/3} (d_0^{1/2})]\}$$

Equation 21

Where:

- η = flare efficiency (dimensionless);
- LHV = lower heating value of the flare gas (MJ/kg);
- U_∞ = wind speed (m/s);
- g = gravitational constant (m/s^2);
- V_j = flare gas exit velocity (m/s);
- d_0 = stack outside diameter (m).

Equation 21 presents the influence of crosswind speed, flare gas exit velocity, flare diameter, and fuel type to flare efficiency. Results show the crosswind has a strong effect on the destruction efficiency. At relatively low values of U_∞ the efficiencies are extremely high, but as U_∞ is increased the efficiency decreases dramatically. The destruction efficiency also depends on the mean fuel jet exit velocity (V_j). Higher velocity fuel jets are less sensitive to the effects of crosswind. The larger diameter flare stacks are more resistant to the effects of increased crosswind speed.

For a stream with greater a heating value ($LHV > 30 \text{ MJ/m}^3$), Equation 21 overestimates the importance of energy density and gives unreasonably high efficiencies. The following correlation should be use in this case:

$$\left\{ \begin{array}{l} \frac{U_\infty}{(gV_j)^{1/3} d_0^{1/2}} < 25 \quad 100 \cdot (1 - \eta) = 0.12375 \cdot \exp\{0.16357 \cdot U_\infty / [(gV_j)^{1/3} (d_0^{1/2})]\} \\ \frac{U_\infty}{(gV_j)^{1/3} d_0^{1/2}} \geq 25 \quad 100 \cdot (1 - \eta) = 14.75 \cdot \ln\{U_\infty / [(gV_j)^{1/3} (d_0^{1/2})]\} - 40.3695 \end{array} \right.$$

Equation 22

8.4.4.2.2 WIND SPEED CORRECTION

The flare destruction efficiency is calculated as a function of the wind speed at the stack top. To relate the wind speed back to wind speed at the standard monitoring height at meteorological monitoring stations, Equation 23 is used:

$$U_{\infty,Z} = U_{\infty,0} \left(\frac{H_Z}{H_0} \right)^n$$

Equation 23

Where:

- U_{∞} = wind speed (m/s);
- H = height (m);
- Z = subscript representing stack top;
- 0 = subscript representing meteorological monitoring station (the height is usually 10 m);
- n = exponential constant ($n = 0.3$ is used for worst case scenario).

8.4.4.3 STEAM-ASSISTED FLARE

The steam assisted flares are often used to promote smoke free operation. High pressure steam is injected into the combustion zone to promote better mixing and to promote complete combustion of the waste gas. The steam amount injected should be optimal to get the desired results. The steam requirement for an industrial flare ranges from 0.01 to 0.6 kg of steam per kg of flare gas (U.S. EPA 2000, 2012). The amount of steam used in the flare should be within this range to achieve high combustion efficiencies. Using excess steam leads to rapid reduction in combustion efficiency of the flare and also results in avoidable loss of steam and its energy. When the steam injection rate for the flare is known the losses associated with the excess steam requirement can be determined as follows:

$$S_{ex} = S_m - 0.6 F_m \quad \text{When } S_m \text{ is greater than } 0.6 F_m$$

Equation 24

Where

- S_{ex} = Excess steam being used (kg/h)
- S_m = Measured steam injection rate (kg/h)
- F_m = Mass Flow Rate of the Flare Gas (kg/h)

When the steam flow rate to the flare is not known or the measured steam mass flow rate is less than 1% of flare gas mass flow rate, the steam requirement for steam assisted flares is determined based on the following U.S. EPA (2000) recommendation:

$$S_{rq} = 0.4 F_m \quad \text{When } S_m \text{ is less than } 0.01 F_m \text{ or } 0$$

Equation 25

Where

$$S_{rq} = \text{Steam Requirement (kg/h)}$$

The energy loss in excess steam is determined using the following equation:

$$E_{ex} = S_{ex} (H_{sb} - H_{wb}) g_c$$

Equation 26

Where

- E_{ex} = Energy loss in excess steam (kW)
- H_{sb} = Enthalpy of steam used at the boiler pressure of the steam source (kJ/kg)
- H_{wb} = Enthalpy of inlet water at the boiler inlet temperature and pressure Conditions (kJ/kg)
- g_c = A constant of proportionality
= 2.778×10^{-4} (h/s)

The enthalpy of steam at appropriate boiler pressure and water at boiler inlet temperature and pressure is determined using steam tables.

Similarly the steam energy requirement to provide the necessary steam flow for a steam assisted flare is determined using the following equation:

$$E_{rq} = (S_{rq} - S_m) (H_{sb} - H_{wb}) g_c \quad \text{When } S_m \text{ is less than } 0.01 F_m \text{ or } 0$$

Equation 27

Where

$$E_{rq} = \text{Energy requirement for extra steam to be provided to the flare (kW).}$$

The fuel energy required for the generation of steam lost or extra steam requirement in a flare is computed as follows:

$$E_{engy\ loss} = \frac{E_{ex}}{\varphi_b} \cdot 100$$

Equation 28

And

$$E_{engy\ req} = \frac{E_{rq}}{\varphi_b} \cdot 100$$

Equation 29

Where

- $E_{engy\ loss}$ = Fuel energy required for steam lost in the flare, (kW)
 $E_{engy\ req}$ = Fuel energy required for extra steam requirement for the flare, (kW)
 φ_b = Boiler efficiency (%)
 = 80 % by default or the actual measured or estimated value when available.

The fuel energy value from Equation 28 or Equation 29 is used to estimate the value of the fuel saved or extra fuel required as follows:

$$V_{fuel} = E_{fuel} \cdot C_{fuel} \cdot g_c$$

Equation 30

Where

- V_{fuel} = Value of fuel saved or cost of extra fuel required (\$/y)above
 E_{fuel} = Energy of fuel saved ($E_{engy\ loss}$) or extra fuel required ($E_{engy\ req}$) (kW)
 C_{fuel} = Price of the fuel (\$/GJ)
 g_c = A constant of proportionality
 = 31.536 (GJ/kJ.s/y)

The emission rates for various combustion products and GHG are computed using the following equation:

$$ER_i = E_{fuel} \cdot EF_{i,b} \cdot g_c$$

Equation 31

Where

$$\begin{aligned} ER_i &= \text{Emission rate of substance 'i', (t/y)} \\ EF_{i,b} &= \text{Emission factor for substance 'i' for the boiler, (ng/J)} \\ g_c &= \text{A constant of proportionality} \\ &= 3.1536 \times 10^{-5} \text{ (t/ng.J/kJ.s/y)} \end{aligned}$$

The emission factors can be estimated either based on combustion analysis of the boiler or the default values of emission factors for industrial boilers provided in US EPA's AP-42 compilation of air pollutant emission factors.

8.4.4.4 AIR-ASSISTED FLARE

Air assisted flares are being used in industry for smokeless operation of flares. Recently US EPA (2012) has published extensive measurement data on the combustion efficiency of air assisted flare operations. The results showed that the mass flow rate for air in air assisted flares should be less than 7 times the stoichiometric air mass flow rate required for the flare gas. The maximum air requirement for an air assisted flare is estimated using the following equation:

$$m_{a,max} = 7 m_{a,stoich}$$

Equation 32

Where

$$\begin{aligned} m_{a,max} &= \text{maximum mass flow rate of air (kg/h).} \\ m_{a,stoich} &= \text{Stoichiometric air requirement for flare gas combustion (kg/h).} \end{aligned}$$

The stoichiometric air requirement for flare gas is determined based on the composition of flare gas. Stoichiometric (or theoretical) combustion is a process which burns all the carbon (C) to CO₂, all hydrogen (H) to H₂O and all sulphur (S) to SO₂.

The excess air used in an air-assisted flare is determined using the following equation:

$$A_{ex} = A_m - m_{a,max}$$

Equation 33

Where

- A_{ex} = Excess air being used (kg/h).
 A_m = Measured air injection rate (kg/h).

The savings in energy consumption of blower or the energy requirement for the air blower for air assisted flare is determined as follows:

$$E_{sav} = \frac{A_{ex} \cdot g_c}{\beta_b \beta_m} \cdot \Delta H_{ad}$$

Equation 34

Where

- E_{sav} = Energy saving potential in air blower (kW)
 β_b = Blower Efficiency (0.70 for typical blower).
 β_m = Blower motor efficiency (0.9 for typical motor).
 A_{ex} = Excess air flow rate (kg/h)
 g_c = A proportionality constant
= 2.778×10^{-4} (h/s).

And

$$\Delta H_{ad} = \frac{RT_a}{8.41} \left[\left(\frac{P_d}{P_a} \right)^{0.283} - 1 \right]$$

Equation 35

Where

- ΔH_{ad} = Adiabatic head generated by blower (kJ/kg).
 R = Universal Gas Constant
= 8.31451 (J/mol/K).
 T_a = Ambient Temperature in absolute (°K).
 P_d = Discharge Pressure in absolute for the blower (kPa).
 P_a = Ambient Pressure in absolute (kPa).

Similarly the maximum power requirement for the blower is determined as follows:

$$E_{b,max} = \frac{m_{a,max} \cdot g_c}{\beta_b \beta_m} \cdot \Delta H_{ad}$$

Equation 36

Where
 $E_{b,max}$ = Maximum energy requirement for air blower (kW).

8.5 FLARE AND VENT GAS CONTROL OPTIONS

Where waste gas can support combustion, it is preferable to flare it than to vent it since this reduces greenhouse gas emissions as well as emissions of volatile organic compounds, air toxics and malodours. Where flares are used they need to be designed and operated to provide good destruction efficiencies, smokeless operation and to be fuel efficient.

There are various measures that may be considered for managing the fuel requirements of flares and for improving their destruction efficiencies. These options include switching to the use of incinerators, installing auto-ignition systems, optimizing purge gas consumption and providing assist gas to ensure smokeless combustion.

For intermittent flares, leakage, into the flare header, of process gas past the seats of pressure relieve valves and blowdown or drain valves can be a significant source of emissions and economic loss. Monitoring flare systems to detect excessive amounts of leakage and implementing a formal program to detect and repair individual leaks can offer attractive economic benefits. Flare gas recovery systems are an option for achieving nearly zero flaring except during process upsets.

For continuous flares, consideration should be given to conserving the gas by compressing it back into the process or a gas gathering system, utilizing the gas for onsite fuel needs or generate electric power (especially where it is possible to wheel the power across the electrical grid for use at other locations). Another option, for streams rich in condensable hydrocarbons, is to install a condenser system to recover the condensable fraction and use the residue gas to power the process and for onsite fuel or to produce electric power.

Further details on each of these opportunities is provided in the subsections below.

8.5.1 INCINERATORS

Incinerators are an alternative to flares that can be considered for disposing of steady continuous waste gas streams with low heating values. These devices maintain waste

gases in the presence of oxygen at higher temperatures for longer residence times than flares. Destruction efficiencies are greater and gases with low calorific values can be more efficiently combusted. In many cases waste gas streams that do not meet the calorific requirements to maintain reliable and stable combustion in a flare can be disposed of using an incinerator without adding any fuel gas. Even in situations where incinerators do require fuel gas to treat a waste stream, the amount of fuel consumed is minimal compared to the make-up gas that would be required to sufficiently enrich the stream for disposal using a flare.

Although incinerators offer a number of benefits, they are not viable alternative to flares in all situations. Incinerators have lower turndown ratios (i.e., typically only 10:1) and higher capital cost than flares.

Instrumentation, including online calorimeters and flow meters, may be used to regulate the delivery of make-up gas to ensure calorific requirements of the combined stream are satisfied while minimizing the amount of fuel gas consumed. This may be particularly beneficial in situations where the composition and flow of the waste gas are variable.

8.5.2 AUTO-IGNITION SYSTEM

The use of electronic ignition devices and/or energy efficient flare pilots can minimize the amount of fuel gas used to sustain flare pilots, while minimizing the potential for flame failure. Often operators will increase purge gas flows to reduce the likelihood of a flame failure which is much less energy efficient or cost effective than investing in a reliable auto-ignition system.

Electronic Ignition Devices- Electronic ignition devices that ensure continuous flare ignition by systematically producing high voltage electric sparks can often be used in place of gas operated pilots. Electric energy consumption is low and is typically supplied by solar recharged batteries.

Energy Efficient Pilots- In situations where pilots cannot be replaced by electronic ignition devices, the fuel efficiency of the gas pilot should be evaluated and consideration given to installing a better design. Efficiency of pilots can be maintained by ensuring that wind shielding and pilot nozzles are in good condition. Some vendors offer designs that consume as little as 0.57m³/h/burner of fuel gas.

8.5.3 SMOKELESS FLARES

Air and steam assisted systems are available that can be used to eliminate flare smoke formation and help improve flare efficiencies. These systems can be retrofit to existing flares but may require some modifications to the flare tip.

A rough order-of-magnitude cost for retrofitting a medium sized flare (e.g., 30 NPS) for smoke free operation is \$150,000 to \$300,000. This does not include installation.

The information needed to evaluate and design a system includes: stack diameter, stack height, flare rate, and flare gas composition. Air assist is preferable for smaller to medium sized applications and steam assist is normally used on larger flares; although, many facilities have converted from steam-assist to air-assist due to the lower operating costs and reduced emissions (i.e., direct and indirect).

An air-assist retrofit installation would include a blower, an air line to the top of the stack and a new flare tip and pilot assembly. The size of the air line would depend on the amount of air required to ensure smokeless operation. There are some basic rules of thumb regarding the mass of assist-air to waste-gas ratios. The existing structure would need to be checked to verify that it could support the additional weight. The size of the air line could be reduced by using higher-pressure air. This may require the use of air from the instrument air system or separate compressor, depending on pressure requirements. One vendor said they have used the derrick legs to transport assist air to the flare tip, assuming the legs are of tubular construction.

The air flow to the stack tip would be controlled by measuring the waste gas flow to the stack (e.g., by linking the blower controls into a flare gas flow meter output signal).

A two-stage flare may also be a good solution, assuming the smoking problems occur at lower relief rates. For example, a second line could be run up the existing stack, with a separate tip and pilot assembly. This option would only be applicable if the waste gas stream has sufficient pressure.

Typical vendors of smokeless flare systems include John Zinc, NAO Inc., Tornado Tech and Flare Industries.

8.5.4 MANAGEMENT OF LEAKING FLARE VALVES

It is reported that 5 to 10 percent of flare valves leak and 1 to 2 percent of those account for 70 percent of the leakage into flare headers. For flare systems that are sized for large relief events, significant amounts of leakage can easily go undetected (i.e., because the incremental flow is not visibly discernible and because the flow meters that are present are generally sized to only record much larger flows during relief or blowdown events).

The use of permanent monitoring systems or facilities should be considered to facilitate easy screening for excessive leakage into flare systems and, where leakage occurs, it should be used to allow a corresponding reduction in the flare purge gas requirements until the leaks can be isolated and repaired. Additionally, consideration should be given to implementing formal programs to detect and quantify individual flare valve leaks (for example, using a [VPAC](#) or similar technology).

Monitoring ports should be provided on all emergency vent and flare lines and blowdown systems to allow convenient periodic detection and quantification of residual flows in these systems where continuous flow meters are not provided or where such meters are only sized to quantify large flow rates (e.g., during relief or blowdown episodes).

Predictive maintenance techniques are preferable to reactive measures and should be considered for applications involving chronic or frequent leakers (e.g., compressor seal vents and leakage into vent and flare systems). This requires the implementation of continuous, frequent or early warning monitoring systems to provide advance notice of developing leaks and to facilitate pre-planning of repair or replacement activities. Devices such as flow switches, flow meters, vapour sensors or transducers for other parameters that provide a good indication of leakage may be installed to allow continuous or frequent detection of leaks from component vent ports and in vent or flare systems.

An effective method of reducing fugitive emissions from pressure relief devices is to install a relief valve with a rupture disk immediately upstream of it, at each relief point. A pressure gauge or suitable tell-tale indicator is needed between the disk and the relief valve to indicate when the disk has failed (ASME, 1989). The rupture disk will shield the relief valve from corrosive process fluids during normal operation. If an overpressure condition occurs, replacement of the disk may be delayed until the next scheduled shutdown period. In the interim, protection against over-pressuring is provided by the relief valve. Sometimes a block valve is installed upstream of the relief system to facilitate early replacement or repair of the components. This use of an upstream block valve is allowed under most Boiler and Pressure Vessel Acts, provided the valve is normally car-sealed open.

The rupture disk should have a set pressure that is slightly higher than that of the relief valve to help avoid simmering problems.

An additional control method is to use resilient valve seats (elastomeric o-rings), as they have superior re-sealing characteristics.

These same strategies may be used to prevent leakage from pressure relief valves that release into closed-vent systems (for example, a flare system). In this case, leakage is difficult to detect and, as a result, may lead to a significant level of waste and cause unnecessary emissions from the combustion device.

The basic rupture disk assembly needed for use upstream of a pressure relief valve comprises a prebulged disk, disk holder, tell-tale indicator, and vent valve. Additionally, a spool piece may be required between the disk and the valve to provide adequate room for the disk to open during a rupture event. There are two basic types of rupture disks that may be used: forward acting and reverse acting. The forward acting disks are the least expensive and most commonly used type. The latter type is used in applications where significant vacuums or pressures may occur on the downstream side of the rupture disk. A forward acting disk would tend to break prematurely in these situations. A standard reason for using a reverse acting rupture disk is to allow the space between the disk and the pressure relief valve to be pressurized to test the set point of the valve in situ and to check for leaks.

For manual blowdown valves, one option to reduce leakage potential is to install a second valve to provide double shutoff protection.

8.5.5 FLARE GAS RECOVERY SYSTEM

Flare gas recovery systems may be used to recovery either continuous waste gas flows or residual flows to a flare or vent system. The recovered gas may be conducted back into the facility inlet pipeline or, if the gas is sweet, put it into the fuel gas system. During a flaring event, the portion of the gas flow that is in excess of the capacity of the flare/vent gas recovery unit simply continues on to the flare/vent outlet.

While it is preferable to control leakage into flare systems at the source, this may not always be practicable. Installing a flare gas recovery system can result in nearly 100 percent reduction of normal residual flaring by intermittent flare systems, limiting flare operation to emergency releases and scheduled maintenance. Given the challenge in trying to manage leakage into flare and vent headers and avoid facility shutdowns to

repair such leaks, the practicability of flare gas recovery systems can often be very attractive, especially at larger facilities where such leakage can be substantial.

Flare gas recovery systems perform the following basic functions:

- Isolation of the flare header with a proprietary-design liquid seal or staging valve.
- Recovery of the normally flared gases.
- Liquids removal.
- Compressing the recovered gases up to a defined pressure level (i.e., so that it can get into an intended pipeline or process for conservation).
- Cooling of recovered gases (if required).
- Delivering the recovered gas into the facility or gathering system, so it can be sent to market or used as fuel gas.
- Typical flare gas recovery systems are sized for the following conditions:
- Flowrate Ranges: 0 to 11,100 m³/h (0 to 10 MMSCFD).
- Pressure Ranges: 240 to 2070 kPa (35 to 300 psig)

8.5.6 PRODUCTION INTO A NEARBY GAS GATHERING SYSTEM

Gas gathering systems collect field gas and transport it to gas processing plants through a network of typically several relatively small diameter (usually 3” NPS to 8 NPS) pipelines. Gathering systems can be very simple, short-distance flow control piping systems for collecting field gas from just a few sources, or complex systems comprising thousands of miles of piping and valves to control the pressure and flow of many sources. The field gas may be water saturated and may be sweet or contain acid gases (H₂S and CO₂) making it sour. The field gas can vary from single phase (gas only) to multi-phase (gas, hydrocarbon condensate and water). Some treating of the gas may be required in the field to meet the operating specification of the gathering system. This treating may include corrosion inhibition, hydrate inhibition, line heating, dehydration and compression.

There are basically three types of natural gas gathering systems used: low-pressure, heated and dehydrated. Low pressure gathering systems may be operated at pressures as low as 525 kPa or less. As the natural gas is produced, some lines have a problem with water condensing and accumulating in low spots. Periodically, it becomes necessary to remove the water from these lines. On long sections of pipeline this is done by pigging (i.e., a specially-designed obstruction is placed in the line, and upstream natural gas pressure is used to push it and any liquid in front of it through to an appropriate discharge point).

Hydrate control is an important consideration in the design of high-pressure natural gas gathering systems. Hydrates are solid crystalline ice-like structures composed of water and hydrocarbon molecules that can form in pipelines and stop the flow. There are two main designs that are used: heated and dehydrated systems.

Heated natural gas gathering systems guard against the formation of hydrates by maintaining the natural gas temperature above some critical value. This critical value is dependent on the composition and pressure of the natural gas; consequently, it varies from one system to the next.

Dehydrated gathering systems prevent the formation of hydrates by removing water vapour from the process natural gas. There are several different dehydration technologies that are used: absorption using diethylene or triethylene glycol; adsorption using solid desiccants such as activated alumina, gels, or molecular sieve; and the chem-sorption process using calcium chloride. The glycol-based absorption process is the most widely used.

Typical costs that need to be considered in evaluating the feasibility of tying in stranded or waste gas into an existing gathering system or in construction of a completely new system are indicated in Table 14.

Table 14: Summary of typical cost categories to be considered in evaluating gas conservation schemes.		
Category	Subcategory	Description
Pipeline	Materials	Pipe / Pipe Coating
		Pipes, Valves & Fittings at each end
		Freight
	Construction	Right-of-Way
		Land Agent Fees
		Surveying
		Mechanical
		River Crossings
		Road Crossings
		Pipeline Crossings
		Supervision and Safety
	Engineering & Regulatory	Approvals & Public Notification
		Engineering
Planning & Drafting		
Procurement & Expediting		
Battery Site Compressor	Equipment	Compressor
		Gas Sweetening
		Gas Drying
		Buildings

Table 14: Summary of typical cost categories to be considered in evaluating gas conservation schemes.

Category	Subcategory	Description
		Pipe, Valves & Fittings
		Freight
	Construction	Civil
		Mechanical
		Electrical & Instrumentation
		Mobilization / Demobilization
		Supervision & Safety
	Engineering & Regulatory	Civil, Mechanical & Process Engineering
		Electrical Engineering
		Controls & Instrumentation
		Planning & Drafting
		Procurement & Expediting

8.5.7 PRODUCTION OF ELECTRIC POWER

There are a broad selection of natural gas-fuelled electric power generator options that have proven to be reliable for use at oilfield facilities. For typical small and medium sized application reciprocating engine and micro turbine driven solutions are available and are discussed in the following subsections. Large scale applications may involve the use of full-size gas turbines or large reciprocating engines.

If the electricity is produced strictly for onsite use then this simplifies the required solution by avoiding the metering and other equipment needed to connect to, and produce into, the electric utility grid. The benefits and efficiency of the solution can be enhanced by implementing a combined heat and power system if there is a need for process or utility heat onsite. Overall thermal efficiencies of up to 90% can be achieved in the case of combined heat and power, and in the range of 30 to 44% in the case of power generation only. For larger application, consideration can be given to extracting the CO₂ from the flue gas for use in enhanced oil recovery.

The composition of associated petroleum gas is often well suited for use as fuel by gas engines. However treatment in the form of dehumidification and removal of condensable hydrocarbons from the gas may be required; especially where the driver for the generator is a reciprocating engine. Due to the often relatively high content of higher hydrocarbons, a derating of the nominal natural gas output may be required. In the case of a high concentration of H₂S, desulphurisation of the gas may also be needed.

For medium to larger sized systems, the engines are normally installed in containerized units with all peripheral systems (ventilation, silencers, cooling, control room) installed inside or on the roof. Turn-key container solutions allow for fast installation and comfortable operation.

8.5.7.1 RECIPROCATING ENGINES

Natural gas fuelled, reciprocating-engine driven power generators that are proven reliable in oilfield applications are available in sizes ranging from 5 to 117 kW in small scale applications and up to 2000 kW in large scale applications. The small scale units would utilize 35 to 828 m³/d of waste natural gas, respectively.

The amount of fuel energy converted to electricity generally increases with engine size, ranging from 30% for small units to 36% for large engines. The amount of fuel converted to thermal energy is from 40 to 50% resulting in overall efficiencies of 80 to 85%. Of the small cogeneration systems available, reciprocating engines offer the highest conversion of fuel energy to electricity.

Reciprocating engines have fairly short start-up times, ranging from 0.5 to 15 minutes, and can tolerate repetitive starts and stops. However, they have a lower available heat recovery than gas turbines, but similar overall energy efficiency.

Reciprocating engines generally have a lower capital cost than other competing technologies, but there is also a slightly higher operating cost associated with oil changes and both top-end and major overhauls. The engines require oil and filter changes at approximately 700 – 1,000 hours of operation and engine head and block rebuild occurs after about 8,000 hours operation. Maintenance costs will tend to increase as the gas quality decreases. Hydrogen sulphide (H₂S) content will increase the frequency of oil changes and potential corrosion problems.

Engine manufacturers consider gaseous fuels containing less than 0.43 mg H₂S/MJ (0.45 µg H₂S/Btu) to be sweet gas, and those that exceed this limit to be sour. Sour fuel gas can reduce the service life of an engine and of the engine oil. When the sulphur compounds are combined with water, acids are produced in the engine oil. These acids attack the metals in the engine crankcase and in other components.

An example of fuel specifications of one engine manufacturer is presented in Table 15 below.

Table 15: Summary of Waukesha gaseous fuel specifications (S7884-7, 3/03).		
Parameter	Limit	Notes
Saturated Lower Heating Value (SLHV)	15.73 MJ/m ³	Biogas applications
Total Organic Halide	150 µg/l	Expressed as chloride (TOH/Cl).
Total Sulfur Compounds	1000 ppmv	Generally based on concentration per fuel heating value.
Total Siloxanes	25 µg/l	Recommend refrigerating gas to 4°C, followed by a 0.3 µm filter and reheat to 29 to 35°C
Liquid Water	None permitted	Dew point should be at least 11°C below temperature of gas entering engine. Saturated is acceptable on engines without prechamber fuel systems.
Solid Particulate	5 micron	

8.5.7.2 MICRO-TURBINES

Micro-turbines are available in various sizes; the options available from one manufacturer are 30kW, 65kW, and 200kW. Products based on the 200kW turbine are also available in 600kW, 800kW, and 1MW configurations. The 30 kW and 65 kW models are UL Certified to meet Class 1, Division 2 NFPA 496. For non-hazardous-area placement, a more affordable stainless steel package is available for each model. Non-hazardous units are UL-certified to meet the new UL220 and UL1741 category for engine generators fueled with “raw natural gas.”

Efficiencies of conversion to electricity range from 15 to 30% depending on size, fuel supply pressure, and whether the design includes a recuperator. Micro-turbine exhaust temperatures are relatively low (about 200 to 300°C) and the waste heat can only be used to generate low pressure steam and/or hot water.

Two types of microturbines are available, recuperated and non-recuperated. Most manufacturers are focusing on recuperated microturbines since they have higher electrical efficiency (but higher capital cost). Recuperators are heat exchangers that pre-heat the

incoming air before it enters the combustor. Excess exhaust heat can be recovered in a cogeneration scheme which several manufacturers have taken advantage of by creating a pre-packaged combined heat and power (CHP) unit (microturbine with integrated heat recovery system). Using cogeneration (i.e. the inclusion of heat recovery) substantially increases the overall efficiency. The heat recovery equipment can be by-passed if it is required to generate power without recovering heat. Some designs allow “banking” where a number of micro turbines supply one heat recovery unit; this can reduce capital costs. Microturbines operating on low pressure waste gas will require an external fuel gas compressor which decreases the net electrical generation scheme efficiency. The required gas pressure is 450 kPag (65 psig).

An example of fuel specifications for a typical micro-turbine is presented in Table 16 below.

Table 16: Summary of typical gaseous fuel specifications for a micro-turbine.		
Parameter	Limit	Notes
Saturated Lower Heating Value (SLHV)	14 MJ/m ³	Biogas applications.
Total Sulfur Compounds	Various up to 10,000 ppmv	Generally recommend H ₂ S removal
Total Siloxanes	Non-detectable	Recommend refrigerating gas to 4°C, followed by a 0.3 μm filter and reheat to 29 to 35°C and carbon filtration.
Liquid Water	None permitted	Gas temperature should be maintained at least 10°C above water dew point.
Solid Particulate	10 micron	Use of coalescing filter recommended.

Micro-turbines use no oil, lubricants, coolants, other hazardous materials, or even water. This eliminates transporting, storage, and costly hazmat spill/leakage issues associated with engine gensets. This reduces scheduled maintenance to mere filter changes twice a year. The first minor scheduled maintenance is at 20,000 hours, an overhaul is suggested by 40,000 hours.

Ingersol Rand, Capstone, Bowman Power, Elliot Ebara, and Turbec manufacture microturbines that are available commercially.

8.5.7.3 GAS TURBINES

Gas turbines range in size from 500 kW to 250 MW. Single cycle turbines have efficiencies from 20 to 45% at full load, with efficiency increasing with size. Combining a gas turbine with a steam turbine cycle can improve efficiencies further to over 50% for large units. Gas turbines generally have a higher capital cost than reciprocating engines but this is balanced by lower operating costs. For plants above 10 MW, gas turbines are generally less expensive than reciprocating engines.

For gas turbines, electrical output decreases with increasing ambient air temperature and increasing elevation due to lower air density. Start-up times are about 2 to 5 minutes.

Gas turbines have three main components: compressor, combustor, and turbine. The compressor compresses the incoming air to high pressure (1100 kPa to 4200 kPa [160 to 610 psig] depending on the manufacturer), fuel is added and combusted to produce high-temperature high-pressure gas, and the turbine extracts energy from this exhaust gas. Some of the energy from the turbine is used to power the compressor and gas pressurization reduces overall output by 2 to 4%.

The additional equipment results in higher parasitic load and capital cost than a reciprocating engine. Although the capital costs associated with turbines are higher than they are with reciprocating engines, maintenance costs are typically lower over the life of the system (providing the fuel gas meets the manufacturer's specification). While reciprocating engines will run on fuel with a low heating value, some turbines will not. This may necessitate natural gas blending.

Turbines are more tolerant of high H₂S content than reciprocating engines (e.g., they accept H₂S concentrations as high as 1% or more with some manufacturers). An example of fuel specifications of one engine manufacturer is resented in Table 17 below.

Parameter	Limit	Notes
Saturated Lower Heating Value (SLHV)	16 MJ/m ³	Biogas applications
Total Sulfur Compounds	Various up to 10,000 ppmv	Manufacturer dependent.
Total Siloxanes	0.1 µg/l (0.087 ppmv) of methane (CH ₄)	Recommend to use carbon filtration or refrigerating gas to 4°C, followed by a 0.3 µm filter and reheat 20°C above dewpoint.

Parameter	Limit	Notes
Liquid Water	None permitted	Dew point typically required to be at least 20°C below temperature of gas entering engine
Solid Particulate	10 micron	Use of 0.3 micron coalescing filter recommended.

Gas turbines require a supply of high pressure feed gas and would require a gas compressor to operate on waste gas streams collected at near atmospheric pressure. This increases the capital cost and reduce the efficiency of conversion to electricity. Construction of cogeneration plants using gas turbines is well developed commercial technology. Typical turbine exhaust temperature is about 500C. A Heat Recovery Steam Generator (HRSG) is installed to recover energy from the turbine exhaust and this energy could be used to supply heat demands for onsite use.

8.5.8 EXTRACTION OF CONDENSABLE HYDROCARBONS

Waste gas streams that are rich in non-methane hydrocarbons may be much more valuable as a source of condensable hydrocarbons than if valued based on the calorific pricing of natural gas. Moreover, where there is no economic access to a natural gas gathering system or need for use of the gas as fuel, recovering the condensable hydrocarbons offers a practical means of obtaining value from the waste gas stream and producing a product that can be more readily transported to market.

Stabilizer overheads, vapours from hydrocarbon storage tanks and waste associated gas from oil production are all potential candidates for recovery of condensable hydrocarbons. The basic objective is to, using a suitable refrigeration process, produce a hydrocarbon liquid product that can be readily:

- Dissolved in, and transported as a stable component of, the crude oil (i.e., whether by tanker or pipeline), or
- Transport the produced liquid as a separated commodity (e.g., by truck or rail).

When effectively processed, the higher-molecular-weight components of the waste gas can be separated from the lighter components to produce two valuable commodities: a hydrocarbon liquid product composed of condensate (or Pentanes Plus) and liquefied

petroleum gas (LPG). The residue gas is available for conservation or use as fuel. Another options is to convert the residue gas to liquefied natural gas that can be transported to market by tanker truck.

At production facilities, the producer can truck the recovered hydrocarbon liquids (i.e., LPG and condensate) as a high vapour pressure product, dissolve it in weathered crude oil and ship it by regular tank truck, or inject it into the crude oil pipeline (if one exists). The last approach reduces evaporation losses, decreases the oil viscosity and, thereby, the specific pipeline energy requirements. It also avoids the need for any onsite pressurized storage facilities for the produced hydrocarbon liquids. When processed downstream, the crude oil enriched with the condensate yields higher fractions of saleable liquid products such as ethane, propane, butane, isobutene and natural gasoline. These liquid fractions have a variety of different uses in the marketplace including enhancing oil recovery in oil wells, feedstock for oil refineries and petrochemical plants, and as sources of energy.

The types of refrigeration cycles used for commercial refrigeration plants are as follows:

- Reversed Carnot cycle (e.g., vapour compression systems like propane, ethane and fluorocarbon refrigeration plants). This is the most efficient refrigeration cycle for operating between two specified temperature levels. Common applications include hydrocarbon dew point control to -40°C , refrigeration systems and air conditioners.
- Reversed Stirling cycle using either an H_2 or He refrigerant.
- Reversed Brayton cycle (i.e., a turbo expander).

There are three different design technologies that may be considered: refrigeration, refrigerated lean oil absorption and Joule-Thomson expansion cooling.

Table 18, Table 19 and Table 20 provide a comparison, for different gas compositions (i.e., 97%, 85% and 77% methane, respectively), of common refrigeration technologies and system sizes that may be considered. Table 21 shows how much of the produced residue gas could potentially be utilized to power the process.

A process flow diagram for a Joule Thompson (JT) plant used to recover hydrocarbon liquids from natural gas streams is presented in Figure 10. The natural gas is compressed to at least 3500 kPa to allow reasonable levels of condensate and LPG recovery. The produced liquids are routed to the inlet separator and the residue gas is used for fuel if there are no practicable conservation or utilization opportunities. A JT plant may be used to recover up to about 45% of the non-methane hydrocarbons and offers minimal CH_4 recovery.

A shallow-cut refrigeration process uses a propane refrigeration system to recover condensate and LPG from natural gas streams. A typical system is sized to process at least $140 \times 10^3 \text{ m}^3/\text{d}$ (or $5900 \text{ m}^3/\text{h}$) of natural gas, operates at pressures of at least 1100 kPa, and costs 0.9 million USD or more (uninstalled). In comparison, a micro condenser unit (see Figure 11) is sized to process 282 to $2832 \text{ m}^3/\text{d}$ (12 to $118 \text{ m}^3/\text{h}$) of natural gas, operates at pressures of about 1100 kPa, and has a capital costs in the order of 0.15 million USD (uninstalled). In either case, the gas may need to be compressed to achieve the specified operating conditions. The recovery efficiency and product characteristics can be controlled by adjusting the chiller operating temperature (e.g., from -25 to -40°C). Typical hydrocarbon liquid recovery efficiencies are in the range of about 45% to 100%. Minimal to 100% liquefaction of methane can be achieved. The greater the methane content of the produced liquids, the greater the potential for a gas phase to develop in the crude oil pipeline if the product is blended with the produced crude oil. Table 22 presents the minimum crude oil flow requirements to prevent two phase formation when blending recovered hydrocarbon liquids (from natural gas streams) with crude oil. The results are presented as a function of the amount of field gas being processed to recover the condensable hydrocarbons and the type of refrigeration process applied.

A micro-LNG plant uses a Stirling cycle super cooler with H_2 as the refrigerant. The resulting system is very modular and is available as a container-sized skid-mounted unit. The components wetted to the process gas are fabricated of stainless steel and the system is highly resistant to H_2S , CO_2 and other contaminants. The system is designed to process up to $8.8 \times 10^3 \text{ m}^3/\text{d}$ ($367 \text{ m}^3/\text{h}$) of natural gas and yields up to $20 \text{ m}^3/\text{d}$ of LNG.

Small-scale LNG plants have capacities in the order of $73.7 \times 10^3 \text{ m}^3/\text{d}$ ($3071 \text{ m}^3/\text{h}$). One option features a single or dual turbo-expander refrigeration process driven using gas engines or electric motors. The process is less efficient when compared to a mixed refrigerant cycle; it uses 15% more power to create the final LNG product. Another option is to have the liquefaction portion of the plant use a combination of propane and ethylene pre-cooling to reduce the power requirements while increasing overall facility capacity.

Medium to large-sized LNG plants feature a single cycle mixed-refrigerant liquefaction process, which is a well-tested, proven and extensively implemented method for creating LNG. The process is well suited to large base-load LNG facilities, but can also be effectively utilized in the design of small and medium scale plants.

Table 18: Comparison of the recovery and energy efficiency of common refrigeration processes for a typical natural gas mixture containing 97% methane.							
Parameter	JT-Plant	Conventional Shallow-Cut	Conventional Deep-Cut	Micro Condenser	Micro LNG	Mini LNG¹	Mid to Large-Sized LNG²
Inlet Pressure	Atm	Atm	Atm	Atm	Atm	Atm	Atm
Cold Separator Operating Pressure (kPag)	799	834	1100	864	834	834	834
% LPG Recovery	4.8	5.0	98.8	5.2	100	100	100
% Pentanes Plus Recovery	76.5	76.8	100.0	77.1	100	100	100
% LNG Recovery	0.04	0.04	9.0	0.04	100	100	100
Energy Intensity (kJ/kg of HC Liq)	57,372	29,130	8,867	36,089	10,347	1,983	675
Energy Efficiency (%)	-19	40	83	25	81	96.4	98.8

1 Comprise C₃ and N₂ refrigeration stages.

2 Comprise C₃ and mixed gas (e.g., C₁, C₂, C₃, C₄ and N₂) refrigeration stages.

Table 19: Comparison of the recovery and energy efficiency of common refrigeration processes for a typical natural gas mixture containing 85% methane.

Parameter	JT-Plant	Conventional Shallow-Cut	Conventional Deep-Cut	Micro Condenser	Micro LNG	Mini LNG¹	Mid to Large-Sized LNG²
Inlet Pressure	Atm	Atm	Atm	Atm	Atm	Atm	Atm
Cold Separator Operating Pressure (kPag)	799	834	1,100	864	834	834	834
% LPG Recovery	16.0	17.3	81.6	18.0	100	100	100
% Pentanes Plus Recovery	79.3	85.1	95.1	85.6	100	100	100
% LNG Recovery	0.4	0.4	5.6	0.4	100	100	100
Energy Intensity (kJ/kg of HC Liq)	16,552	10,498	5,015	9,613	9,630	1,839	591
Energy Efficiency (%)	66	78	90	80	82	96.5	98.9

1 Comprise C₃ and N₂ refrigeration stages.

2 Comprise C₃ and mixed gas (e.g., C₁, C₂, C₃, C₄ and N₂) refrigeration stages.

Table 20: Comparison of the recovery and energy efficiency of common refrigeration processes for a typical natural gas mixture containing 73% methane.

Parameter	JT-Plant	Conventional Shallow-Cut	Conventional Deep-Cut	Micro Condenser	Micro LNG	Mini LNG¹	Mid to Large-Sized LNG²
Inlet Pressure	Atm	Atm	Atm	Atm	Atm	Atm	Atm
Cold Separator Operating Pressure (kPag)	799	834	1,100	864	834	834	834
% LPG Recovery	24.3	24.9	84.2	25.6	100	100	100
% Pentanes Plus Recovery	91.4	91.7	99.4	92.0	100	100	100
% LNG Recovery	0.5	0.5	4.6	0.5	100	100	100
Energy Intensity (kJ/kg of HC Liq)	10,879	6,832	5,172	6,487	8,404	1,758	542
Energy Efficiency (%)	77	86	89	87	79	95.7	98.7

1 Comprise C₃ and N₂ refrigeration stages.

2 Comprise C₃ and mixed gas (e.g., C₁, C₂, C₃, C₄ and N₂) refrigeration stages.

Table 21: Percentage of the residue gas produced by selected liquids recovery technologies, and for different field gas compositions, that may potentially be utilized to power the process.			
Technologies	Percentage Residue Gas Utilization in Refrigeration Plant¹ (%)		
	97% Methane	85% Methane	73% Methane & 13% Nitrogen
JT Plant	7	2	2
Conventional Shallow Cut	4	1	1
Conventional Deep Cut	8	5	6
Microcondenser	4	1	1
Micro LNG	71	69	79
Mini LNG	14	13	17
Small or Large Size LNG	5	4	5

- 1 The percentage of the produced residue gas that could potentially be utilized to power the hydrocarbon liquids recovery process is estimated based on the electric power demands of the process and the efficiencies involved in generating the electric power using the residue gas. An engine efficiency of 30 percent and a generator efficiency of 90 percent are assumed.

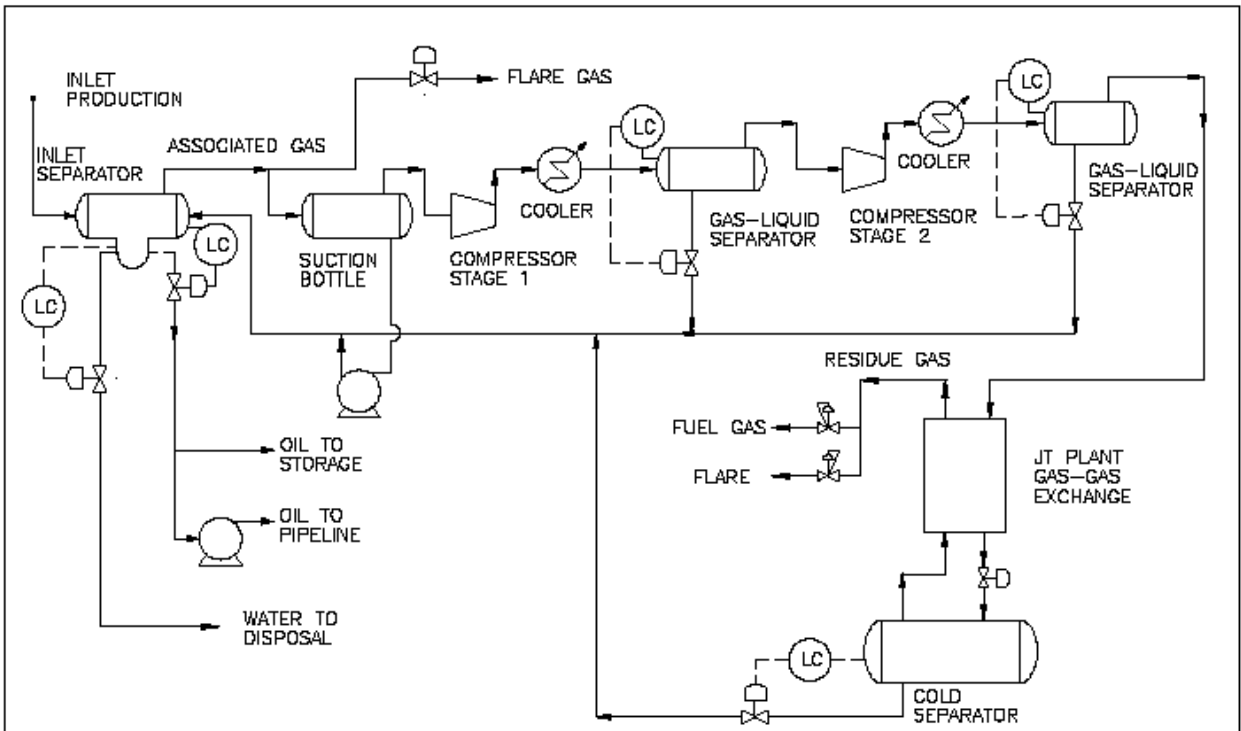

REFERENCE DRAWINGS	DATE	BY	DESCRIPTION	BY	DATE	APPROVAL	DATE

DESIGNER'S SIGNATURE	DATE	PROJECT NO.	SCALE	NTS	APPROVED	DATE

	Process Flow Diagram - Hydrocarbon Liquids Recovery System	General
<small>OLANASTROM ENGINEERING LTD.</small>	<small>CL-001</small>	<small>0</small>

THE DRAWING AND DESIGN IT CONTAINS ARE CONFIDENTIAL AND THE PROPERTY OF OLANASTROM ENGINEERING LTD. IT SHALL NOT BE DISCLOSED TO OTHERS OR REPRODUCED IN ANY MANNER OR USED FOR ANY PURPOSE WHATSOEVER EXCEPT BY WRITTEN CONSENT OF OLANASTROM.

Figure 10: Process flow diagram of a Joule-Thompson (JT) plant for recovery of non-methane hydrocarbons from natural gas streams.

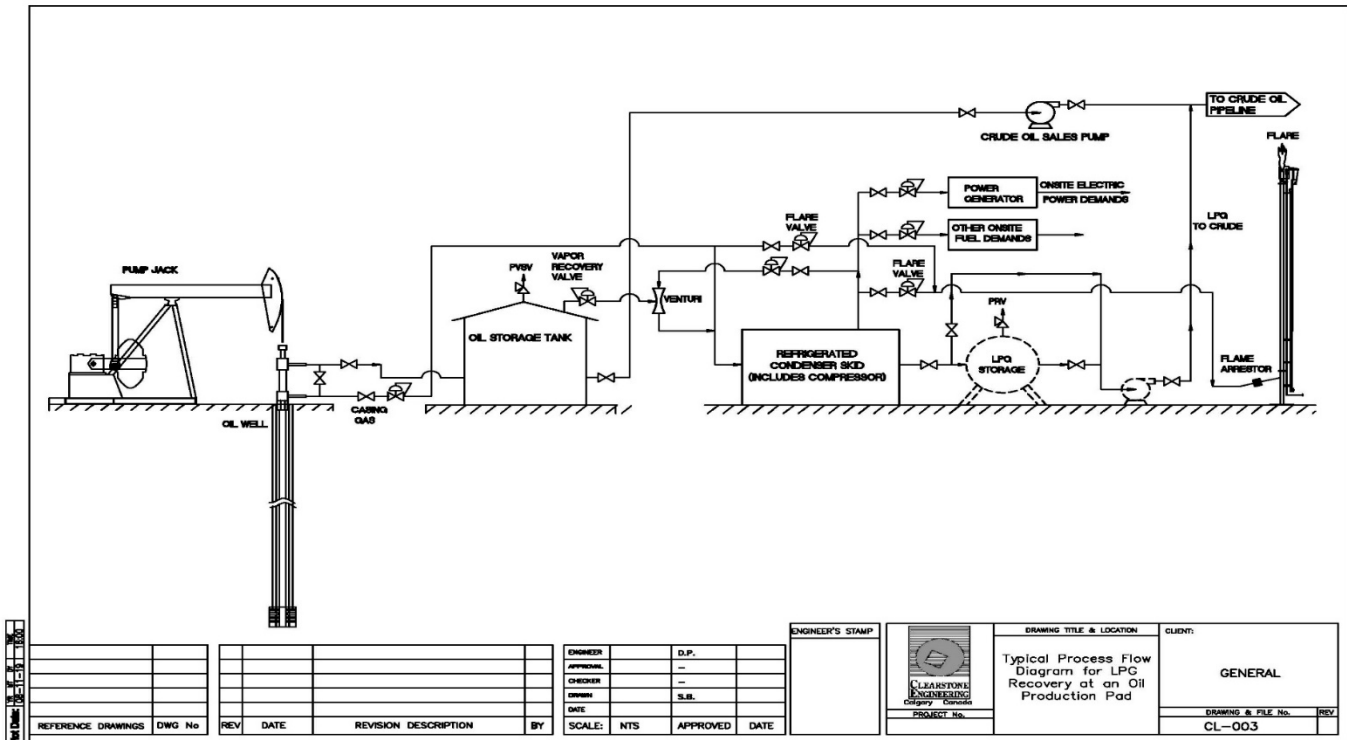

REFERENCE DRAWINGS		DWG No		REV		DATE		REVISION DESCRIPTION		BY	

ENGINEER	D.P.	
APPROVAL		
CHECKER		
OWNER	S.U.	
DATE		
SCALE: NTS	APPROVED	DATE

ENGINEER'S STAMP	
------------------	--

 CLEARSTONE ENGINEERING <small>Category: Electrical</small> PRODUCT No.	DRAWING TITLE & LOCATION Typical Process Flow Diagram for LPC Recovery at an Oil Production Pad	CLIENT: GENERAL
		DRAWING & FILE No. CL-003

THE DRAWING AND DESIGN IT COVERS ARE CONFIDENTIAL AND THE PROPERTY OF CLEARSTONE ENGINEERING LTD. IT SHALL NOT BE DISCLOSED TO OTHERS OR REPRODUCED IN ANY MANNER OR USED FOR ANY PURPOSE WHATSOEVER EXCEPT BY WRITTEN CONSENT OF CLEARSTONE.

Figure 11: Process flow diagram of a micro-condenser system used to extract condensable hydrocarbons from associated gas and vapours from the production tank at a typical oil production facility.

Table 22: Minimum crude oil flow requirement to prevent two-phase formation in the crude oil pipeline expressed as a function of the amount of waste gas processed to recover condensable hydrocarbons (m³ crude oil per day / 10³ m³ of waste gas processed per day).				
Pressure in Crude Oil Pipeline (psig)	JT Plant		Shallow-cut Refrigeration Plant	
	75% Methane Field Gas	63% Methane Field Gas	75% Methane Field Gas	63% Methane Field Gas
50	0.027	0.959	2.136	7.128
75	0.016	0.536	1.920	4.464
100	<0.016	0.299	0.888	3.048
125	<0.016	0.144	0.624	2.160
150	<0.016	0.035	0.432	1.536

8.6 REFERENCES CITED

ERCB. 2006. Directive 060, Upstream Petroleum Industry Flaring, Incinerating, and Venting, Energy Resources Conservation Board, Alberta, Canada

CAPP. 2008. Fuel Gas Best management Practices, Efficient use of fuel gas in flaring operations, Canadian Association of Petroleum Producer

U.S. Environmental Protection Agency. 1998. *Compilation of Pollution Emission Factors, Vol.1, Station and Point Area Sources, AP-42(5th Edition)*. North Carolina. (<http://www.epa.gov/ttn/chief/ap42/ch1/final/c01s04.pdf>)

U.S. EPA. 2000. *EPA Air Pollution Control Cost Manual – Sixth Edition, Section 3.2 VOC Destruction Controls, Chapter 1 Flares* (EPA/542/B-02-001). United States Environmental Protection Agency. <http://www.epa.gov/ttn/catc/dir1/cs3-2ch1.pdf>

U.S. EPA. 2012. *EPA Parameters for properly designed and operated flares, Section 3.4.2* (EPA/542/B-02-001). United States Environmental Protection Agency. <http://www.epa.gov/airtoxics/flare/2012flaretechreport.pdf>

Johnson, M.R., Zastavniuk, O., Dale J.D., and Kostiuk, L.W. 1999. The Combustion Efficiency of Jet Diffusion Flames in Cross-flow. Paper presented at the Joint Meeting of the United States Sections – The Combustion Institute, Washington, D.C.

8.7 RESULTS

The detailed vent and flare analysis results are presented below:



CLEARSTONE
ENGINEERING

Flares Index

Device	Facility	Device Category	Device Type
CCAC.1.1	CCAC.1	Flares	Flare Stack (Unassisted)
CCAC.2.2	CCAC.2	Flares	Flare Stack (Unassisted)
CCAC.2.3	CCAC.2	Flares	Flare Stack (Air Assist)
CCAC.2.4	CCAC.2	Flares	Flare Stack (Unassisted)
CCAC.3.5	CCAC.3	Flares	Flare Stack (Unassisted)
CCAC.4.6	CCAC.4	Flares	Flare Stack (Unassisted)
CCAC.5.7	CCAC.5	Flares	Flare Stack (Unassisted)
CCAC.6.8	CCAC.6	Flares	Flare Stack (Unassisted)
CCAC.7.18	CCAC.7	Flares	Flare Stack (Unassisted)
CCAC.7.19	CCAC.7	Flares	Flare Stack (Unassisted)
CCAC.7.9	CCAC.7	Flares	Flare Pit



Flare Analysis Information

Facility	
Clearstone Client	CCAC.1
Data Client	CCAC.1
Operator	CCAC.1
Name	CCAC.1
Location	CCAC.1
ID	CCAC.1
Category	Battery
Type	Oil Multi-Well
Government ID	CCAC.1
Operator BA Code	CCAC.1
Licensee BA Code	CCAC.1
Licensee Name	CCAC.1

General Analysis Data	
System Life (y)	10.0
Decline Rate ¹ (%/y)	15.0
Ambient Temperature (°C)	30.0
Ambient Pressure (kPa)	100.4
Average Wind Speed (m/s)	5.0
Met Station Height (m)	10.0
Stack Top Temperature (°C)	25.0
Knockout Drum Temp (°C)	25.0
Knockout Drum Pressure (kPag)	0.0

¹ The applied annaly production decline rate used to reduce primary gas flows in economics assumptions, to model decline production. 0 indicates an assumption of steady flow for the systems life.

Data Comments and Assumptions
CCAC.1.1

Data Administration Details	
Period Start	2014-09-29
Period End	2014-10-08
Data Contact	Chris Lusena
Prepared By	Chris Lusena
Report Generated	7-Dec-2015

Device	
Name	CCAC.1.1
ID	CCAC.1.1
On Site Location	CCAC.1.1
Type	Flare Stack (Unassisted)
Service	Associated Gas Disposal
Manufacturer	N/A
Model	N/A
Model Year	N/A
Installation Date	N/A

Device Comments and Assumptions
CCAC.1.1

Applied Emission Factors (ng/J)		
Substance	Value	Source
CH ₄ Emission Factor	33.10	US EPA AP-42
N ₂ O Emission Factor	0.10	US EPA AP-42
VOC Emission Factor	5.16	Calculated
CO Emission Factor	159.10	US EPA AP-42
PM Emission Factor	57.00	US EPA AP-42
NO _x Emission Factor	29.20	US EPA AP-42
HC Destruction Efficiency (%)	99.82	Calculated

Flare Stream and Stack Measurements

Property	Stream(s)
	Waste
Temperature (°C)	37.3
Pressure (kPa gage)	102.3
Line Name	CCAC.1.1
Cross Sectional Shape	Circular
Pipe Outside Diameter (mm)	113.0
Pipe Wall Thickness (mm)	1.0
Pipe Rectangular Length (mm)	N/A
Pipe Rectangular Width (mm)	N/A
Measurement Type	Inline Tracer Test
Reading Type	Flow Rate Standard Conditions
Measurement Date	Oct 7 2014 11:30AM
Velocity (m/s)	---
Flow Rate (m ³ /h)	---
Standard Flow Rate (std m ³ /h)	1,080.9
Composition Name	CCAC.Comp.2
Composition ID	CCAC.Comp.2

Stack Details	
Flare End Seal Type	Plain
Stack Outside Diameter (m)	0.11
Flare Wall Thickness (mm)	5.9
Flare Stack Height (m)	12.19
Auto-ignition	No
Pilot present	No
Knockout Drum Diameter (m)	N/A
Knockout Drum Length(m)	N/A

Waste Stream Composition Source Data

Analysis Administration Data	
Name	CCAC.Comp.2
Description and Comments	CCAC.Comp.2
Creation Date	2014-12-10
Sample Date	N/A
Sample Type	Computed (Gas/Molar)
Substance Type	Waste Gas
Clearstone ID	CCAC.Comp.2

Analysis Results			
Component Name	Mole Fraction		
	Entered	Normalized	Air Free
Carbon dioxide	0.061814	0.061814	0.061814
Ethane	0.052676	0.052676	0.052676
Hydrogen sulfide	0.001070	0.001070	0.001070
Isobutane	0.008419	0.008419	0.008419
Isopentane	0.002883	0.002883	0.002883
Methane	0.826408	0.826408	0.826408
n-Butane	0.011786	0.011786	0.011786
n-Hexane	0.000095	0.000095	0.000095
Nitrogen	0.002340	0.002340	0.002340
n-Pentane	0.000211	0.000211	0.000211
Propane	0.032296	0.032296	0.032296
Total	1.000000	1.000000	1.000000

Flare FuelComposition Source Data

Analysis Administration Data	
Name	CCAC.Comp.2
Description and Comments	CCAC.Comp.2
Creation Date	2014-12-10
Sample Date	N/A
Sample Type	Computed (Gas/Molar)
Substance Type	Waste Gas
Clearstone ID	CCAC.Comp.2

Analysis Results			
Component Name	Mole Fraction		
	Entered	Normalized	Air Free
Carbon dioxide	0.061814	0.061814	0.061814
Ethane	0.052676	0.052676	0.052676
Hydrogen sulfide	0.001070	0.001070	0.001070
Isobutane	0.008419	0.008419	0.008419
Isopentane	0.002883	0.002883	0.002883
Methane	0.826408	0.826408	0.826408
n-Butane	0.011786	0.011786	0.011786
n-Hexane	0.000095	0.000095	0.000095
Nitrogen	0.002340	0.002340	0.002340
n-Pentane	0.000211	0.000211	0.000211
Propane	0.032296	0.032296	0.032296
Total	1.000000	1.000000	1.000000

Flare Stack Analysis Results

Purge Gas	
Minimum Flow (m ³ /h)	0.0
Current Flow (m ³ /h)	
Excess Flow (m ³ /h)	0.0

Pilot Gas	
Minimum Flow (m ³ /h)	4.0
Current Flow (m ³ /h)	
Excess Flow (m ³ /h)	0.0

Calculated Flare Stack Gas Composition	
Component Name	Mole Fraction
Methane	0.826408
Carbon dioxide	0.061814
Ethane	0.052676
Propane	0.032296
n-Butane	0.011786
Isobutane	0.008419
Isopentane	0.002883
Nitrogen	0.002340
Hydrogen sulfide	0.001070
n-Pentane	0.000211
n-Hexane	0.000095
Total	1.000000

Flare Stack Gas	
Dew Temperature (°C)	-61.3
Optimal Conditions Dew Temperature (°C)	-61.3
Stack Liquid Formation Potential	No
Knockout Drum Liquid Formation	No
Calculated HC Destruction (%)	99.82%
Calculated VOC Emission Factor (ng/J)	5.16
Calculated Flare Gas Flow (m ³ /h)	1,080.9

Stack Hydrocarbon Destruction Efficiency Vs. Wind Speed

Wind Speed (m/s)	HC DE (%)
0.0	99.88
1.0	99.87
2.0	99.86
3.0	99.85
4.0	99.84
5.0	99.82
6.0	99.81
7.0	99.80
8.0	99.78
9.0	99.77
10.0	99.75
11.0	99.73
12.0	99.71
13.0	99.69
14.0	99.67
15.0	99.64
16.0	99.62
17.0	99.59
18.0	99.56
19.0	99.53
20.0	99.49

Analysis Results

Source Name	Source Tag No.	Service Type
CCAC.1.1	CCAC.1.1	Associated Gas Disposal

Year Calculation Type	Value of Fuel/Loss Stream (USD/y)	Total Product Loss Flow (m ³ /h)	Total Product Losses				
			Residue Gas (10 ³ m ³ /d)	Ethane (m ³ /d liq)	LPG (m ³ /d liq)	C ₅ + (m ³ /d)	Hydrogen (m ³ /d)
Average	728,755	524.8	10.41	2.36	2.57	0.20	0.00
Year-0	1,500,928	1,080.9	21.44	4.85	5.28	0.41	0.00

Year Calculation Type	Total (Direct and Indirect) Emissions (t/y)								
	CH ₄	CO ₂	N ₂ O	CO ₂ E	VOC	CO	NO _x	SO ₂	PM
Average	51.6	10,160	0.02	11,248	4.2	29.9	5.5	13.3	10.7
Total	515.6	101,601	0.18	112,484	41.9	299.0	54.9	133.3	107.1
Year-0	106.2	20,926	0.04	23,167	8.6	61.6	11.3	27.4	22.1

Potential Control Options

Control Technology Type	Energy Recovery Efficiency (%)	Capital Cost (USD)	Net Present Salvage Value (USD)	Net Operating Cost (USD/y)	Value of Conserved Energy (USD/y)	NPV (10 ³ USD)	ROI (%)	Payback Period (y)
Recover Condensable Hydrocarbons &	0.00	5,188,800	0	0	247,261	-4,331	2.44	N/A

Control Technology Type	Year Calculation Type	Estimated Emission Reduction Potential (t/y)								
		CH ₄	CO ₂	N ₂ O	CO ₂ E	VOC	CO	NO _x	SO ₂	PM
Recover Condensable Hydrocarbons & Flare Excess Residue Gas	Average	0.07	684	0.00	685	0.25	1.81	0.33	0.00	0.65
	Total	0.68	6,836	0.01	6,854	2.53	18.08	3.32	0.00	6.48
	Year-0	0.14	1,408	0.00	1,412	0.52	3.72	0.68	0.00	1.33

Control Technology Input

Device and Facility	
Clearstone Client	CCAC.1.1
Data Client	CCAC.1.1
Device Facility	CCAC.1
Device Name	CCAC.1.1
Device ID	CCAC.1.1

Economic Assumptions	
System Life (y)	10.0
Application Life (y)	10.0
Electrical Usage Rating (kWh/y)	0
Replacement Salvage Value (USD)	0
Technology EOL Salvage Value (USD)	0
Operating Cost (USD/y)	0
Operating Cost Factor	1.000
Operating Costs Avoided (USD/y)	N/A

Control Technology Comments
CCAC.1.1

Control Technology	
Type	Recover Condensable Hydrocarbons & Flare Excess
Combustion Type	Flare Stack (Unassisted)
Stream Reduction Factor (%)	0.00
Hydrocarbon Reduction Factor (%)	0.00
Sulphur Reduction Factor (%)	0.00
Application Description	Pesimistic cost

Applied Emission Factors ¹		
Substance	Value	Source
CH ₄ Emission Factor (ng/J)	33.10	US EPA AP-42
N ₂ O Emission Factor (ng/J)	0.10	US EPA AP-42
VOC Emission Factor (ng/J)	5.16	User Entered
CO Emission Factor (ng/J)	159.10	US EPA AP-42
PM Emission Factor (ng/J)	57.00	US EPA AP-42
NO _x Emission Factor (ng/J)	29.20	US EPA AP-42
HC Destruction Efficiency (%)	99.83	User Entered

¹ Emission Factors used in simulation if the Control Technology consumes fuel as part of its operation.

Property	Stream(s)
	Recovery
Temperature (°C)	15
Pressure (kPa gage)	0
Line Name	CCAC.1.1
Cross Sectional Shape	Circular
Pipe Outside Diameter (mm)	N/A
Pipe Wall Thickness (mm)	N/A
Pipe Rectangular Length (mm)	N/A
Pipe Rectangular Width (mm)	N/A
Measurement Type	Process Simulation
Reading Type	Molar Flow Rate
Measurement Date	N/A
Velocity (m/s)	---
Flow Rate (m ³ /h)	---
Standard Flow Rate (std m ³ /h)	57.1876
Composition Name	CCAC.Comp.1
Composition ID	CCAC.Comp.1

Composition Source Data

Analysis Administration Data	
Name	CCAC.Comp.1
Description and Comments	CCAC.Comp.1
Creation Date	2015-11-30
Sample Date	N/A
Sample Type	Computed (Gas/Molar)
Substance Type	Unknown
Clearstone ID	CCAC.Comp.1

Analysis Results			
Component Name	Mole Fraction		
	Entered	Normalized	Air Free
Ethane	0.073284	0.073284	0.073284
Isobutane	0.178816	0.178816	0.178816
Isopentane	0.105032	0.105032	0.105032
Methane	0.048565	0.048565	0.048565
n-Butane	0.305799	0.305799	0.305799
n-Hexane	0.004113	0.004113	0.004113
Nitrogen	0.000019	0.000019	0.000019
n-Pentane	0.007990	0.007990	0.007990
Propane	0.276382	0.276382	0.276382
Total	1.000000	1.000000	1.000000

Production Decline Economics

Application Life (years)	Monetary Discount Rate (%/year)	Applied Production Decline Rate (%/year)	Assumed Inflation Rate (%/year)
10.0	10.0	15.0	0.0

Year	Revenues ¹ (USD)	Costs ¹ (USD)	Net Revenues (USD)	Net Present Value ² (USD)	ROI ³ (%)
0	0	5,188,800	-5,188,800	-5,188,800	—
1	215,923	0	215,923	196,294	4.2
1	215,923	0	215,923	196,294	4.2
1	215,923	0	215,923	196,294	4.2
1	215,923	0	215,923	196,294	4.2
2	188,557	0	188,557	155,832	3.6
2	188,557	0	188,557	155,832	3.6
2	188,557	0	188,557	155,832	3.6
2	188,557	0	188,557	155,832	3.6
3	164,659	0	164,659	123,711	3.2
3	164,659	0	164,659	123,711	3.2
3	164,659	0	164,659	123,711	3.2
3	164,659	0	164,659	123,711	3.2
4	143,790	0	143,790	98,211	2.8
4	143,790	0	143,790	98,211	2.8
4	143,790	0	143,790	98,211	2.8
4	143,790	0	143,790	98,211	2.8
5	125,566	0	125,566	77,967	2.4
5	125,566	0	125,566	77,967	2.4
5	125,566	0	125,566	77,967	2.4
5	125,566	0	125,566	77,967	2.4
6	109,652	0	109,652	61,896	2.1
6	109,652	0	109,652	61,896	2.1
6	109,652	0	109,652	61,896	2.1
6	109,652	0	109,652	61,896	2.1
7	95,755	0	95,755	49,137	1.8
7	95,755	0	95,755	49,137	1.8
7	95,755	0	95,755	49,137	1.8
7	95,755	0	95,755	49,137	1.8
8	83,619	0	83,619	39,009	1.6
8	83,619	0	83,619	39,009	1.6
8	83,619	0	83,619	39,009	1.6
8	83,619	0	83,619	39,009	1.6

9	73,021	0	73,021	30,968	1.4
9	73,021	0	73,021	30,968	1.4
9	73,021	0	73,021	30,968	1.4
9	73,021	0	73,021	30,968	1.4
10	63,766	0	63,766	24,585	1.2
10	63,766	0	63,766	24,585	1.2
10	63,766	0	63,766	24,585	1.2
10	63,766	0	63,766	24,585	1.2
Total	5,057,237	5,188,800	-131,563	-1,758,363	2.4

¹ For year 0 Costs and Revenues represent capital cost and salvage values. For other years they represent operating cost and revenues in current year dollars.

² Net Present Value is expressed in Year-0 dollars.

³ ROI is current year net revenues over capital cost in Year-0 dollars. The Total row for this column is the median ROI value over the operating years.

Capital Cost Details

Control Technology Type	Application description
Recover Condensable Hydrocarbons & Flare Excess Residue Gas	Pesimistic cost

Cost Category	Cost Item Type	Item Description	Rate (USD/Unit)	Quantity (Unit)	Line Total (USD)
Lump sum	Lump sum	prorated cost (\$/m3/h)	4,800.00	1,081.0	5,188,800

Total 5,188,800



Flare Analysis Information

Facility	
Clearstone Client	CCAC.2
Data Client	CCAC.2
Operator	CCAC.2
Name	CCAC.2
Location	CCAC.2
ID	CCAC.2
Category	Tank Farm (Terminal)
Type	Pipeline
Government ID	CCAC.2
Operator BA Code	CCAC.2
Licensee BA Code	CCAC.2
Licensee Name	CCAC.2

Data Administration Details	
Period Start	2014-09-29
Period End	2014-10-08
Data Contact	Chris Lusena
Prepared By	Chris Lusena
Report Generated	7-Dec-2015

Device	
Name	CCAC.2.2
ID	CCAC.2.2
On Site Location	CCAC.2.2
Type	Flare Stack (Unassisted)
Service	Continuous Waste Gas Disposal
Manufacturer	N/A
Model	N/A
Model Year	N/A
Installation Date	N/A

General Analysis Data	
System Life (y)	20.0
Decline Rate ¹ (%/y)	0.0
Ambient Temperature (°C)	26.0
Ambient Pressure (kPa)	100.9
Average Wind Speed (m/s)	5.0
Met Station Height (m)	10.0
Stack Top Temperature (°C)	25.0
Knockout Drum Temp (°C)	25.0
Knockout Drum Pressure (kPag)	0.0

Device Comments and Assumptions
CCAC.2.2

¹ The applied annaly production decline rate used to reduce primary gas flows in economics assumptions, to model decline production. 0 indicates an assumption of steady flow for the systems life.

Data Comments and Assumptions
CCAC.2.2

Applied Emission Factors (ng/J)		
Substance	Value	Source
CH ₄ Emission Factor	33.10	US EPA AP-42
N ₂ O Emission Factor	0.10	US EPA AP-42
VOC Emission Factor	38.88	Calculated
CO Emission Factor	159.10	US EPA AP-42
PM Emission Factor	57.00	US EPA AP-42
NO _x Emission Factor	29.20	US EPA AP-42
HC Destruction Efficiency (%)	99.46	Calculated

Flare Stream and Stack Measurements

Property	Stream(s)
	Waste
Temperature (°C)	33.8
Pressure (kPa gage)	102.3
Line Name	CCAC.2.2
Cross Sectional Shape	Circular
Pipe Outside Diameter (mm)	401.6
Pipe Wall Thickness (mm)	9.4
Pipe Rectangular Length (mm)	N/A
Pipe Rectangular Width (mm)	N/A
Measurement Type	Inline Tracer Test
Reading Type	Flow Rate Standard Conditions
Measurement Date	Sep 30 2014 11:13AM
Velocity (m/s)	---
Flow Rate (m ³ /h)	---
Standard Flow Rate (std m ³ /h)	51.1
Composition Name	CCAC.Comp.4
Composition ID	CCAC.Comp.4

Stack Details	
Flare End Seal Type	Unknown
Stack Outside Diameter (m)	0.90
Flare Wall Thickness (mm)	9.4
Flare Stack Height (m)	12.19
Auto-ignition	No
Pilot present	No
Knockout Drum Diameter (m)	N/A
Knockout Drum Length(m)	N/A

Waste Stream Composition Source Data

Analysis Administration Data	
Name	CCAC.Comp.4
Description and Comments	CCAC.Comp.4
Creation Date	2014-12-04
Sample Date	2014-01-01
Sample Type	As Sampled (Gas/Molar)
Substance Type	Fuel Gas
Clearstone ID	CCAC.Comp.4

Analysis Results			
Component Name	Mole Fraction		
	Entered	Normalized	Air Free
Benzene	0.000080	0.000080	0.000080
Carbon dioxide	0.004630	0.004630	0.004630
Ethane	0.183620	0.183620	0.183620
Ethylbenzene	0.000010	0.000010	0.000010
Isobutane	0.011710	0.011710	0.011710
Isopentane	0.007340	0.007340	0.007340
Methane	0.592920	0.592920	0.592920
m-Xylene	0.000005	0.000005	0.000005
n-Butane	0.032550	0.032550	0.032550
n-Heptane	0.002650	0.002650	0.002650
n-Hexane	0.004430	0.004430	0.004430
Nitrogen	0.044090	0.044090	0.044090
n-Nonane	0.000020	0.000020	0.000020
n-Octane	0.000320	0.000320	0.000320
n-Pentane	0.009190	0.009190	0.009190
Propane	0.106370	0.106370	0.106370
p-Xylene	0.000005	0.000005	0.000005
Toluene	0.000060	0.000060	0.000060
Total	1.000000	1.000000	1.000000

Flare FuelComposition Source Data

Analysis Administration Data	
Name	CCAC.Comp.4
Description and Comments	CCAC.Comp.4
Creation Date	2014-12-04
Sample Date	2014-01-01
Sample Type	As Sampled (Gas/Molar)
Substance Type	Fuel Gas
Clearstone ID	CCAC.Comp.4

Analysis Results			
Component Name	Mole Fraction		
	Entered	Normalized	Air Free
Benzene	0.000080	0.000080	0.000080
Carbon dioxide	0.004630	0.004630	0.004630
Ethane	0.183620	0.183620	0.183620
Ethylbenzene	0.000010	0.000010	0.000010
Isobutane	0.011710	0.011710	0.011710
Isopentane	0.007340	0.007340	0.007340
Methane	0.592920	0.592920	0.592920
m-Xylene	0.000005	0.000005	0.000005
n-Butane	0.032550	0.032550	0.032550
n-Heptane	0.002650	0.002650	0.002650
n-Hexane	0.004430	0.004430	0.004430
Nitrogen	0.044090	0.044090	0.044090
n-Nonane	0.000020	0.000020	0.000020
n-Octane	0.000320	0.000320	0.000320
n-Pentane	0.009190	0.009190	0.009190
Propane	0.106370	0.106370	0.106370
p-Xylene	0.000005	0.000005	0.000005
Toluene	0.000060	0.000060	0.000060
Total	1.000000	1.000000	1.000000

Flare Stack Analysis Results

Purge Gas	
Minimum Flow (m ³ /h)	51.1
Current Flow (m ³ /h)	
Excess Flow (m ³ /h)	0.0

Pilot Gas	
Minimum Flow (m ³ /h)	11.9
Current Flow (m ³ /h)	
Excess Flow (m ³ /h)	0.0

Calculated Flare Stack Gas Composition	
Component Name	Mole Fraction
Methane	0.592920
Ethane	0.183620
Propane	0.106370
Nitrogen	0.044090
n-Butane	0.032550
Isobutane	0.011710
n-Pentane	0.009190
Isopentane	0.007340
Carbon dioxide	0.004630
n-Hexane	0.004430
n-Heptane	0.002650
n-Octane	0.000320
Benzene	0.000080
Toluene	0.000060
n-Nonane	0.000020
Ethylbenzene	0.000010
m-Xylene	0.000005
p-Xylene	0.000005
Total	1.000000

Flare Stack Gas	
Dew Temperature (°C)	-10.9
Optimal Conditions Dew Temperature (°C)	-10.9
Stack Liquid Formation Potential	No
Knockout Drum Liquid Formation	No
Calculated HC Destruction (%)	99.46%
Calculated VOC Emission Factor (ng/J)	38.88
Calculated Flare Gas Flow (m ³ /h)	51.1

Stack Hydrocarbon Destruction Efficiency Vs. Wind Speed

Wind Speed (m/s)	HC DE (%)
0.0	99.88
1.0	99.83
2.0	99.78
3.0	99.70
4.0	99.60
5.0	99.46
6.0	99.27
7.0	99.02
8.0	98.68
9.0	98.23
10.0	97.62
11.0	96.80
12.0	95.69
13.0	94.21
14.0	92.70
15.0	91.69
16.0	90.73
17.0	89.84
18.0	89.00
19.0	88.20
20.0	87.44

Analysis Results

Source Name	Source Tag No.	Service Type	Value of Fuel/Loss Stream (USD/y)	Total Product Loss Flow (m ³ /h)	Total Product Losses				
					Residue Gas (10 ³ m ³ /d)	Ethane (m ³ /d liq)	LPG (m ³ /d liq)	C ₅ + (m ³ /d)	Hydrogen (m ³ /d)
CCAC.2.2	CCAC.2.2	Continuous Waste Gas Disposal	139,824	51.1	0.73	0.80	0.71	0.15	0.00

Total (Direct and Indirect) Emissions (t/y)								
CH ₄	CO ₂	N ₂ O	CO ₂ E	VOC	CO	NO _x	SO ₂	PM
3.6	1,327	0.00	1,403	0.5	3.9	0.7	0.0	1.4

No Control Technology Results



Flare Analysis Information

Facility	
Clearstone Client	CCAC.2
Data Client	CCAC.2
Operator	CCAC.2
Name	CCAC.2
Location	CCAC.2
ID	CCAC.2
Category	Tank Farm (Terminal)
Type	Pipeline
Government ID	CCAC.2
Operator BA Code	CCAC.2
Licensee BA Code	CCAC.2
Licensee Name	CCAC.2

Data Administration Details	
Period Start	2014-09-29
Period End	2014-10-08
Data Contact	Chris Lusena
Prepared By	Chris Lusena
Report Generated	7-Dec-2015

Device	
Name	CCAC.2.3
ID	CCAC.2.3
On Site Location	CCAC.2.3
Type	Flare Stack (Air Assist)
Service	Stabilizer Overheads Disposal
Manufacturer	N/A
Model	N/A
Model Year	N/A
Installation Date	N/A

General Analysis Data	
System Life (y)	20.0
Decline Rate ¹ (%/y)	0.0
Ambient Temperature (°C)	0.0
Ambient Pressure (kPa)	101.3
Average Wind Speed (m/s)	5.0
Met Station Height (m)	10.0
Stack Top Temperature (°C)	25.0
Knockout Drum Temp (°C)	25.0
Knockout Drum Pressure (kPag)	25.0

Device Comments and Assumptions
CCAC.2.3

¹ The applied annaly production decline rate used to reduce primary gas flows in economics assumptions, to model decline production. 0 indicates an assumption of steady flow for the systems life.

Data Comments and Assumptions
CCAC.2.3

Applied Emission Factors (ng/J)		
Substance	Value	Source
CH ₄ Emission Factor	33.10	US EPA AP-42
N ₂ O Emission Factor	0.10	US EPA AP-42
VOC Emission Factor	52.46	Calculated
CO Emission Factor	159.10	US EPA AP-42
PM Emission Factor	57.00	US EPA AP-42
NO _x Emission Factor	29.20	US EPA AP-42
HC Destruction Efficiency (%)	99.58	Calculated

Flare Stream and Stack Measurements

Property	Stream(s)
	Waste
Temperature (°C)	36.8
Pressure (kPa gage)	102.2
Line Name	CCAC.2.3
Cross Sectional Shape	Circular
Pipe Outside Diameter (mm)	9.4
Pipe Wall Thickness (mm)	903.6
Pipe Rectangular Length (mm)	N/A
Pipe Rectangular Width (mm)	N/A
Measurement Type	Inline Tracer Test
Reading Type	Flow Rate Standard Conditions
Measurement Date	Sep 30 2014 12:00AM
Velocity (m/s)	---
Flow Rate (m ³ /h)	---
Standard Flow Rate (std m ³ /h)	432.3
Composition Name	CCAC.Comp.6
Composition ID	CCAC.Comp.6

Stack Details	
Flare End Seal Type	Unknown
Stack Outside Diameter (m)	1.81
Flare Wall Thickness (mm)	9.4
Flare Stack Height (m)	45.72
Auto-ignition	No
Pilot present	Yes
Knockout Drum Diameter (m)	N/A
Knockout Drum Length(m)	N/A

Waste Stream Composition Source Data

Analysis Administration Data	
Name	CCAC.Comp.6
Description and Comments	CCAC.Comp.6
Creation Date	2015-09-27
Sample Date	2015-09-01
Sample Type	As Sampled (Gas/Molar)
Substance Type	Unknown
Clearstone ID	CCAC.Comp.6

Analysis Results			
Component Name	Mole Fraction		
	Entered	Normalized	Air Free
Ethane	0.225206	0.225185	0.225185
Hydrogen sulfide	0.047756	0.047751	0.047751
Isobutane	0.057846	0.057840	0.057840
Methane	0.310996	0.310968	0.310968
n-Butane	0.156145	0.156130	0.156130
n-Pentane	0.003595	0.003595	0.003595
Propane	0.198548	0.198530	0.198530
Total	1.000090	1.000000	1.000000

Flare FuelComposition Source Data

Analysis Administration Data	
Name	CCAC.Comp.4
Description and Comments	CCAC.Comp.4
Creation Date	2014-12-04
Sample Date	2014-01-01
Sample Type	As Sampled (Gas/Molar)
Substance Type	Fuel Gas
Clearstone ID	CCAC.Comp.4

Analysis Results			
Component Name	Mole Fraction		
	Entered	Normalized	Air Free
Benzene	0.000080	0.000080	0.000080
Carbon dioxide	0.004630	0.004630	0.004630
Ethane	0.183620	0.183620	0.183620
Ethylbenzene	0.000010	0.000010	0.000010
Isobutane	0.011710	0.011710	0.011710
Isopentane	0.007340	0.007340	0.007340
Methane	0.592920	0.592920	0.592920
m-Xylene	0.000005	0.000005	0.000005
n-Butane	0.032550	0.032550	0.032550
n-Heptane	0.002650	0.002650	0.002650
n-Hexane	0.004430	0.004430	0.004430
Nitrogen	0.044090	0.044090	0.044090
n-Nonane	0.000020	0.000020	0.000020
n-Octane	0.000320	0.000320	0.000320
n-Pentane	0.009190	0.009190	0.009190
Propane	0.106370	0.106370	0.106370
p-Xylene	0.000005	0.000005	0.000005
Toluene	0.000060	0.000060	0.000060
Total	1.000000	1.000000	1.000000

Flare Stack Analysis Results

Purge Gas	
Minimum Flow (m ³ /h)	0.0
Current Flow (m ³ /h)	
Excess Flow (m ³ /h)	0.0

Pilot Gas	
Minimum Flow (m ³ /h)	15.9
Current Flow (m ³ /h)	
Excess Flow (m ³ /h)	0.0

Calculated Flare Stack Gas Composition	
Component Name	Mole Fraction
Methane	0.310968
Ethane	0.225185
Propane	0.198530
n-Butane	0.156130
Isobutane	0.057840
Hydrogen sulfide	0.047751
n-Pentane	0.003595
Total	1.000000

Flare Stack Gas	
Dew Temperature (°C)	-29.7
Optimal Conditions Dew Temperature (°C)	-29.7
Stack Liquid Formation Potential	No
Knockout Drum Liquid Formation	No
Calculated HC Destruction (%)	99.58%
Calculated VOC Emission Factor (ng/J)	52.46
Calculated Flare Gas Flow (m ³ /h)	432.3

Stack Hydrocarbon Destruction Efficiency Vs. Wind Speed

Wind Speed (m/s)	HC DE (%)
0.0	99.88
1.0	99.84
2.0	99.80
3.0	99.74
4.0	99.67
5.0	99.58
6.0	99.46
7.0	99.30
8.0	99.11
9.0	98.86
10.0	98.54
11.0	98.14
12.0	97.62
13.0	96.95
14.0	96.10
15.0	95.00
16.0	93.61
17.0	92.53
18.0	91.68
19.0	90.89
20.0	90.13

Analysis Results

Source Name	Source Tag No.	Service Type	Value of Fuel/Loss Stream (USD/y)	Total Product Loss Flow (m ³ /h)	Total Product Losses				
					Residue Gas (10 ³ m ³ /d)	Ethane (m ³ /d liq)	LPG (m ³ /d liq)	C ₅ + (m ³ /d)	Hydrogen (m ³ /d)
CCAC.2.3	CCAC.2.3	Stabilizer Overheads Disposal	2,193,946	432.3	3.23	8.30	16.91	0.18	0.00

Total (Direct and Indirect) Emissions (t/y)								
CH ₄	CO ₂	N ₂ O	CO ₂ E	VOC	CO	NO _x	SO ₂	PM
4.0	15,722	0.03	15,815	6.2	44.2	8.1	489.9	15.8

Potential Control Options

Control Technology Type	Energy Recovery Efficiency (%)	Capital Cost (USD)	Net Present Salvage Value (USD)	Net Operating Cost (USD/y)	Value of Conserved Energy (USD/y)	NPV (10 ³ USD)	ROI (%)	Payback Period (y)
Return To Plant Inlet	95.00	534,000	0	21,978	2,084,249	17,023	386.19	0.26

Control Technology Type	Estimated Emission Reduction Potential (t/y)								
	CH ₄	CO ₂	N ₂ O	CO ₂ E	VOC	CO	NO _x	SO ₂	PM
Return To Plant Inlet	-0.79	14,518	-0.02	14,494	5.46	39.98	4.61	465.42	15.05

Control Technology Input

Device and Facility	
Clearstone Client	CCAC.2.3
Data Client	CCAC.2.3
Device Facility	CCAC.2
Device Name	CCAC.2.3
Device ID	CCAC.2.3

Economic Assumptions	
System Life (y)	20.0
Application Life (y)	20.0
Electrical Usage Rating (kWh/y)	0
Replacement Salvage Value (USD)	N/A
Technology EOL Salvage Value (USD)	0
Operating Cost (USD/y)	0
Operating Cost Factor	1.000
Operating Costs Avoided (USD/y)	N/A

Control Technology Comments
CCAC.2.3

Control Technology	
Type	Return To Plant Inlet
Combustion Type	4-Stroke Lean-Burn (90-105% load)
Stream Reduction Factor (%)	95.00
Hydrocarbon Reduction Factor (%)	0.00
Sulphur Reduction Factor (%)	0.00
Application Description	Recompress stream to Inlet pressures.

Applied Emission Factors ¹		
Substance	Value	Source
CH ₄ Emission Factor (ng/J)	538.00	US EPA AP-42
N ₂ O Emission Factor (ng/J)	5.72	US EPA AP-42
VOC Emission Factor (ng/J)	51.00	US EPA AP-42
CO Emission Factor (ng/J)	136.00	US EPA AP-42
PM Emission Factor (ng/J)	0.03	US EPA AP-42
NO _x Emission Factor (ng/J)	1754.00	US EPA AP-42
HC Destruction Efficiency (%)	N/A	

¹ Emission Factors used in simulation if the Control Technology consumes fuel as part of its operation.

Control Technology Stream Measurements

Property	Stream(s)
	Fuel
Temperature (°C)	15
Pressure (kPa gage)	0
Line Name	CCAC.2.3
Cross Sectional Shape	Circular
Pipe Outside Diameter (mm)	10
Pipe Wall Thickness (mm)	1
Pipe Rectangular Length (mm)	N/A
Pipe Rectangular Width (mm)	N/A
Measurement Type	Back Calculated Based on Measured Unit Output
Reading Type	Flow Rate Standard Conditions
Measurement Date	N/A
Velocity (m/s)	---
Flow Rate (m ³ /h)	---
Standard Flow Rate (std m ³ /h)	25.6431
Composition Name	CCAC.Comp.3
Composition ID	CCAC.Comp.3

Composition Source Data

Analysis Administration Data	
Name	CCAC.Comp.3
Description and Comments	CCAC.Comp.3
Creation Date	2015-11-03
Sample Date	N/A
Sample Type	As Sampled (Gas/Molar)
Substance Type	Unknown
Clearstone ID	CCAC.Comp.3

Analysis Results			
Component Name	Mole Fraction		
	Entered	Normalized	Air Free
Methane	1.000000	1.000000	1.000000
Total	1.000000	1.000000	1.000000

Capital Cost Details

Control Technology Type	Application description
Return To Plant Inlet	Recompress stream to Inlet pressures.

Cost Category	Cost Item Type	Item Description	Rate (USD/Unit)	Quantity (Unit)	Line Total (USD)
Lump sum	Lump sum	Cost (\$/m3/h)	1,200.00	445.0	534,000

Total 534,000



Flare Analysis Information

Facility	
Clearstone Client	CCAC.2
Data Client	CCAC.2
Operator	CCAC.2
Name	CCAC.2
Location	CCAC.2
ID	CCAC.2
Category	Tank Farm (Terminal)
Type	Pipeline
Government ID	CCAC.2
Operator BA Code	CCAC.2
Licensee BA Code	CCAC.2
Licensee Name	CCAC.2

Data Administration Details	
Period Start	2014-09-29
Period End	2014-10-08
Data Contact	Chris Lusena
Prepared By	Chris Lusena
Report Generated	7-Dec-2015

Device	
Name	CCAC.2.4
ID	CCAC.2.4
On Site Location	CCAC.2.4
Type	Flare Stack (Unassisted)
Service	Continuous Waste Gas Disposal
Manufacturer	N/A
Model	N/A
Model Year	N/A
Installation Date	N/A

General Analysis Data	
System Life (y)	20.0
Decline Rate ¹ (%/y)	0.0
Ambient Temperature (°C)	0.0
Ambient Pressure (kPa)	101.0
Average Wind Speed (m/s)	5.0
Met Station Height (m)	10.0
Stack Top Temperature (°C)	25.0
Knockout Drum Temp (°C)	25.0
Knockout Drum Pressure (kPag)	0.0

Device Comments and Assumptions
CCAC.2.4

¹ The applied annaly production decline rate used to reduce primary gas flows in ecnomics assumptions, to model decline production. 0 indicates an assumption of steady flow for the systems life.

Data Comments and Assumptions
CCAC.2.4

Applied Emission Factors (ng/J)		
Substance	Value	Source
CH ₄ Emission Factor	33.10	US EPA AP-42
N ₂ O Emission Factor	0.10	US EPA AP-42
VOC Emission Factor	16.59	Calculated
CO Emission Factor	159.10	US EPA AP-42
PM Emission Factor	57.00	US EPA AP-42
NO _x Emission Factor	29.20	US EPA AP-42
HC Destruction Efficiency (%)	99.80	Calculated

Flare Stream and Stack Measurements

Property	Stream(s)
	Waste
Temperature (°C)	37.2
Pressure (kPa gage)	102.3
Line Name	CCAC.2.4
Cross Sectional Shape	Circular
Pipe Outside Diameter (mm)	401.6
Pipe Wall Thickness (mm)	9.4
Pipe Rectangular Length (mm)	N/A
Pipe Rectangular Width (mm)	N/A
Measurement Type	Inline Tracer Test
Reading Type	Flow Rate Standard Conditions
Measurement Date	Sep 29 2014 1:30PM
Velocity (m/s)	---
Flow Rate (m ³ /h)	---
Standard Flow Rate (std m ³ /h)	2,269.8
Composition Name	CCAC.Comp.7
Composition ID	CCAC.Comp.7

Stack Details	
Flare End Seal Type	Unknown
Stack Outside Diameter (m)	0.60
Flare Wall Thickness (mm)	9.4
Flare Stack Height (m)	22.86
Auto-ignition	No
Pilot present	Yes
Knockout Drum Diameter (m)	N/A
Knockout Drum Length(m)	N/A

Waste Stream Composition Source Data

Analysis Administration Data	
Name	CCAC.Comp.7
Description and Comments	CCAC.Comp.7
Creation Date	2015-09-27
Sample Date	2015-08-31
Sample Type	As Sampled (Gas/Molar)
Substance Type	Unknown
Clearstone ID	CCAC.Comp.7

Analysis Results			
Component Name	Mole Fraction		
	Entered	Normalized	Air Free
Carbon dioxide	0.000870	0.000870	0.000870
Ethane	0.277725	0.277735	0.277735
Hydrogen sulfide	0.021278	0.021279	0.021279
Isobutane	0.021139	0.021140	0.021140
Methane	0.436533	0.436548	0.436548
n-Butane	0.061224	0.061226	0.061226
Nitrogen	0.017000	0.017001	0.017001
n-Pentane	0.005364	0.005364	0.005364
Propane	0.158831	0.158837	0.158837
Total	0.999965	1.000000	1.000000

Flare FuelComposition Source Data

Analysis Administration Data	
Name	CCAC.Comp.4
Description and Comments	CCAC.Comp.4
Creation Date	2014-12-04
Sample Date	2014-01-01
Sample Type	As Sampled (Gas/Molar)
Substance Type	Fuel Gas
Clearstone ID	CCAC.Comp.4

Analysis Results			
Component Name	Mole Fraction		
	Entered	Normalized	Air Free
Benzene	0.000080	0.000080	0.000080
Carbon dioxide	0.004630	0.004630	0.004630
Ethane	0.183620	0.183620	0.183620
Ethylbenzene	0.000010	0.000010	0.000010
Isobutane	0.011710	0.011710	0.011710
Isopentane	0.007340	0.007340	0.007340
Methane	0.592920	0.592920	0.592920
m-Xylene	0.000005	0.000005	0.000005
n-Butane	0.032550	0.032550	0.032550
n-Heptane	0.002650	0.002650	0.002650
n-Hexane	0.004430	0.004430	0.004430
Nitrogen	0.044090	0.044090	0.044090
n-Nonane	0.000020	0.000020	0.000020
n-Octane	0.000320	0.000320	0.000320
n-Pentane	0.009190	0.009190	0.009190
Propane	0.106370	0.106370	0.106370
p-Xylene	0.000005	0.000005	0.000005
Toluene	0.000060	0.000060	0.000060
Total	1.000000	1.000000	1.000000

Flare Stack Analysis Results

Purge Gas	
Minimum Flow (m ³ /h)	0.0
Current Flow (m ³ /h)	
Excess Flow (m ³ /h)	0.0

Pilot Gas	
Minimum Flow (m ³ /h)	7.9
Current Flow (m ³ /h)	
Excess Flow (m ³ /h)	0.0

Calculated Flare Stack Gas Composition	
Component Name	Mole Fraction
Methane	0.436548
Ethane	0.277735
Propane	0.158837
n-Butane	0.061226
Hydrogen sulfide	0.021279
Isobutane	0.021140
Nitrogen	0.017001
n-Pentane	0.005364
Carbon dioxide	0.000870
Total	1.000000

Flare Stack Gas	
Dew Temperature (°C)	-42.3
Optimal Conditions Dew Temperature (°C)	-42.3
Stack Liquid Formation Potential	No
Knockout Drum Liquid Formation	No
Calculated HC Destruction (%)	99.80%
Calculated VOC Emission Factor (ng/J)	16.59
Calculated Flare Gas Flow (m ³ /h)	2,269.8

Stack Hydrocarbon Destruction Efficiency Vs. Wind Speed

Wind Speed (m/s)	HC DE (%)
0.0	99.88
1.0	99.86
2.0	99.85
3.0	99.84
4.0	99.82
5.0	99.80
6.0	99.78
7.0	99.76
8.0	99.74
9.0	99.71
10.0	99.68
11.0	99.65
12.0	99.62
13.0	99.58
14.0	99.54
15.0	99.49
16.0	99.44
17.0	99.39
18.0	99.33
19.0	99.26
20.0	99.19

Analysis Results

Source Name	Source Tag No.	Service Type	Value of Fuel/Loss Stream (USD/y)	Total Product Loss Flow (m ³ /h)	Total Product Losses				
					Residue Gas (10 ³ m ³ /d)	Ethane (m ³ /d liq)	LPG (m ³ /d liq)	C ₅ + (m ³ /d)	Hydrogen (m ³ /d)
CCAC.2.4	CCAC.2.4	Continuous Waste Gas Disposal	7,717,555	2,269.8	23.78	53.75	50.67	1.42	0.00

Total (Direct and Indirect) Emissions (t/y)								
CH ₄	CO ₂	N ₂ O	CO ₂ E	VOC	CO	NO _x	SO ₂	PM
117.8	67,567	0.12	70,077	27.2	194.4	35.7	1146.4	69.6

Potential Control Options

Control Technology Type	Energy Recovery Efficiency (%)	Capital Cost (USD)	Net Present Salvage Value (USD)	Net Operating Cost (USD/y)	Value of Conserved Energy (USD/y)	NPV (10 ³ USD)	ROI (%)	Payback Period (y)
Return To Plant Inlet	95.00	1,062,153	0	61,940	3,011,220	24,047	277.67	0.36

Control Technology Type	Estimated Emission Reduction Potential (t/y)								
	CH ₄	CO ₂	N ₂ O	CO ₂ E	VOC	CO	NO _x	SO ₂	PM
Return To Plant Inlet	99.06	63,017	-0.03	65,090	24.66	181.39	-7.98	1,089.09	66.15

Control Technology Input

Device and Facility	
Clearstone Client	CCAC.2.4
Data Client	CCAC.2.4
Device Facility	CCAC.2
Device Name	CCAC.2.4
Device ID	CCAC.2.4

Economic Assumptions	
System Life (y)	20.0
Application Life (y)	20.0
Electrical Usage Rating (kWh/y)	0
Replacement Salvage Value (USD)	N/A
Technology EOL Salvage Value (USD)	0
Operating Cost (USD/y)	0
Operating Cost Factor	1.000
Operating Costs Avoided (USD/y)	N/A

Control Technology Comments
CCAC.2.4

Control Technology	
Type	Return To Plant Inlet
Combustion Type	4-Stroke Lean-Burn (<90% load)
Stream Reduction Factor (%)	95.00
Hydrocarbon Reduction Factor (%)	0.00
Sulphur Reduction Factor (%)	0.00
Application Description	Recompress To Inlet

Applied Emission Factors ¹		
Substance	Value	Source
CH ₄ Emission Factor (ng/J)	538.00	US EPA AP-42
N ₂ O Emission Factor (ng/J)	5.72	US EPA AP-42
VOC Emission Factor (ng/J)	51.00	US EPA AP-42
CO Emission Factor (ng/J)	240.00	US EPA AP-42
PM Emission Factor (ng/J)	0.03	US EPA AP-42
NO _x Emission Factor (ng/J)	364.00	US EPA AP-42
HC Destruction Efficiency (%)	N/A	

¹ Emission Factors used in simulation if the Control Technology consumes fuel as part of its operation.

Control Technology Stream Measurements

Property	Stream(s)
	Fuel
Temperature (°C)	15
Pressure (kPa gage)	0
Line Name	CCAC.2.4
Cross Sectional Shape	Circular
Pipe Outside Diameter (mm)	10
Pipe Wall Thickness (mm)	1
Pipe Rectangular Length (mm)	N/A
Pipe Rectangular Width (mm)	N/A
Measurement Type	Back Calculated Based on Measured Unit Output
Reading Type	Flow Rate Standard Conditions
Measurement Date	N/A
Velocity (m/s)	---
Flow Rate (m ³ /h)	---
Standard Flow Rate (std m ³ /h)	71.8533
Composition Name	CCAC.Comp.3
Composition ID	CCAC.Comp.3

Composition Source Data

Analysis Administration Data	
Name	CCAC.Comp.3
Description and Comments	CCAC.Comp.3
Creation Date	2015-11-03
Sample Date	N/A
Sample Type	As Sampled (Gas/Molar)
Substance Type	Unknown
Clearstone ID	CCAC.Comp.3

Analysis Results			
Component Name	Mole Fraction		
	Entered	Normalized	Air Free
Methane	1.000000	1.000000	1.000000
Total	1.000000	1.000000	1.000000

Capital Cost Details

Control Technology Type	Application description
Return To Plant Inlet	Recompress To Inlet

Cost Category	Cost Item Type	Item Description	Rate (USD/Unit)	Quantity (Unit)	Line Total (USD)
Lump sum	Lump sum	per m3/h	467.95	2,269.8	1,062,153

Total 1,062,153



Flare Analysis Information

Facility	
Clearstone Client	CCAC.3
Data Client	CCAC.3
Operator	CCAC.3
Name	CCAC.3
Location	CCAC.3
ID	CCAC.3
Category	Battery
Type	Oil Multi-Well
Government ID	CCAC.3
Operator BA Code	CCAC.3
Licensee BA Code	CCAC.3
Licensee Name	CCAC.3

General Analysis Data	
System Life (y)	10.0
Decline Rate ¹ (%/y)	15.0
Ambient Temperature (°C)	0.0
Ambient Pressure (kPa)	101.3
Average Wind Speed (m/s)	5.0
Met Station Height (m)	10.0
Stack Top Temperature (°C)	25.0
Knockout Drum Temp (°C)	25.0
Knockout Drum Pressure (kPag)	0.0

¹ The applied annaly production decline rate used to reduce primary gas flows in economics assumptions, to model decline production. 0 indicates an assumption of steady flow for the systems life.

Data Comments and Assumptions
CCAC.3.5

Data Administration Details	
Period Start	2014-09-29
Period End	2014-10-08
Data Contact	Chris Lusena
Prepared By	Chris Lusena
Report Generated	7-Dec-2015

Device	
Name	CCAC.3.5
ID	CCAC.3.5
On Site Location	CCAC.3.5
Type	Flare Stack (Unassisted)
Service	Associated Gas Disposal
Manufacturer	N/A
Model	N/A
Model Year	N/A
Installation Date	N/A

Device Comments and Assumptions
CCAC.3.5

Applied Emission Factors (ng/J)		
Substance	Value	Source
CH ₄ Emission Factor	33.10	US EPA AP-42
N ₂ O Emission Factor	0.10	US EPA AP-42
VOC Emission Factor	11.97	Calculated
CO Emission Factor	159.10	US EPA AP-42
PM Emission Factor	57.00	US EPA AP-42
NO _x Emission Factor	29.20	US EPA AP-42
HC Destruction Efficiency (%)	99.83	Calculated

Flare Stream and Stack Measurements

Property	Stream(s)
	Waste
Temperature (°C)	34.7
Pressure (kPa gage)	102.9
Line Name	CCAC.3.5
Cross Sectional Shape	Circular
Pipe Outside Diameter (mm)	113.0
Pipe Wall Thickness (mm)	6.2
Pipe Rectangular Length (mm)	N/A
Pipe Rectangular Width (mm)	N/A
Measurement Type	Inline Tracer Test
Reading Type	Flow Rate Standard Conditions
Measurement Date	Oct 8 2014 10:55AM
Velocity (m/s)	---
Flow Rate (m ³ /h)	---
Standard Flow Rate (std m ³ /h)	1,299.9
Composition Name	CCAC.Comp.10
Composition ID	CCAC.Comp.10

Stack Details	
Flare End Seal Type	Unknown
Stack Outside Diameter (m)	0.11
Flare Wall Thickness (mm)	5.9
Flare Stack Height (m)	12.19
Auto-ignition	No
Pilot present	Yes
Knockout Drum Diameter (m)	N/A
Knockout Drum Length(m)	N/A

Waste Stream Composition Source Data

Analysis Administration Data	
Name	CCAC.Comp.10
Description and Comments	CCAC.Comp.10
Creation Date	2014-12-10
Sample Date	N/A
Sample Type	Computed (Gas/Molar)
Substance Type	Waste Gas
Clearstone ID	CCAC.Comp.10

Analysis Results			
Component Name	Mole Fraction		
	Entered	Normalized	Air Free
Carbon dioxide	0.231820	0.231815	0.231815
Ethane	0.132710	0.132707	0.132707
Isobutane	0.012190	0.012190	0.012190
Isopentane	0.003690	0.003690	0.003690
Methane	0.493650	0.493640	0.493640
n-Butane	0.026110	0.026109	0.026109
n-Hexane	0.000140	0.000140	0.000140
Nitrogen	0.001820	0.001820	0.001820
n-Pentane	0.002960	0.002960	0.002960
Propane	0.094930	0.094928	0.094928
Total	1.000020	1.000000	1.000000

Flare FuelComposition Source Data

Analysis Administration Data	
Name	CCAC.Comp.9
Description and Comments	CCAC.Comp.9
Creation Date	2014-12-04
Sample Date	2014-02-09
Sample Type	As Sampled (Gas/Molar)
Substance Type	Process Gas
Clearstone ID	CCAC.Comp.9

Analysis Results			
Component Name	Mole Fraction		
	Entered	Normalized	Air Free
Carbon dioxide	0.159934	0.159934	0.159934
Ethane	0.091561	0.091561	0.091561
Isobutane	0.008409	0.008409	0.008409
Isopentane	0.002543	0.002543	0.002543
Methane	0.650658	0.650658	0.650658
n-Butane	0.018011	0.018011	0.018011
n-Hexane	0.000097	0.000097	0.000097
Nitrogen	0.001254	0.001254	0.001254
n-Pentane	0.002041	0.002041	0.002041
Propane	0.065492	0.065492	0.065492
Total	1.000000	1.000000	1.000000

Flare Stack Analysis Results

Purge Gas	
Minimum Flow (m ³ /h)	0.0
Current Flow (m ³ /h)	
Excess Flow (m ³ /h)	0.0

Pilot Gas	
Minimum Flow (m ³ /h)	4.0
Current Flow (m ³ /h)	
Excess Flow (m ³ /h)	0.0

Calculated Flare Stack Gas Composition	
Component Name	Mole Fraction
Methane	0.493640
Carbon dioxide	0.231815
Ethane	0.132707
Propane	0.094928
n-Butane	0.026109
Isobutane	0.012190
Isopentane	0.003690
n-Pentane	0.002960
Nitrogen	0.001820
n-Hexane	0.000140
Total	1.000000

Flare Stack Gas	
Dew Temperature (°C)	-49.3
Optimal Conditions Dew Temperature (°C)	-49.3
Stack Liquid Formation Potential	No
Knockout Drum Liquid Formation	No
Calculated HC Destruction (%)	99.83%
Calculated VOC Emission Factor (ng/J)	11.97
Calculated Flare Gas Flow (m ³ /h)	1,299.9

Stack Hydrocarbon Destruction Efficiency Vs. Wind Speed

Wind Speed (m/s)	HC DE (%)
0.0	99.88
1.0	99.87
2.0	99.86
3.0	99.85
4.0	99.84
5.0	99.83
6.0	99.81
7.0	99.80
8.0	99.79
9.0	99.77
10.0	99.76
11.0	99.74
12.0	99.72
13.0	99.70
14.0	99.68
15.0	99.66
16.0	99.64
17.0	99.61
18.0	99.59
19.0	99.56
20.0	99.53

Analysis Results

Source Name	Source Tag No.	Service Type
CCAC.3.5	CCAC.3.5	Associated Gas Disposal

Year Calculation Type	Value of Fuel/Loss Stream (USD/y)	Total Product Loss Flow (m ³ /h)	Total Product Losses				
			Residue Gas (10 ³ m ³ /d)	Ethane (m ³ /d liq)	LPG (m ³ /d liq)	C ₅ + (m ³ /d)	Hydrogen (m ³ /d)
Average	1,331,323	631.1	7.48	7.14	7.72	0.50	0.00
Year-0	2,741,963	1,299.9	15.40	14.71	15.91	1.04	0.00

Year Calculation Type	Total (Direct and Indirect) Emissions (t/y)								
	CH ₄	CO ₂	N ₂ O	CO ₂ E	VOC	CO	NO _x	SO ₂	PM
Average	37.0	15,055	0.02	15,839	5.2	37.1	6.8	0.0	13.3
Total	370.4	150,548	0.22	158,394	52.1	371.5	68.2	0.0	133.1
Year-0	76.3	31,006	0.05	32,623	10.7	76.5	14.0	0.0	27.4

Potential Control Options

Control Technology Type	Energy Recovery Efficiency (%)	Capital Cost (USD)	Net Present Salvage Value (USD)	Net Operating Cost (USD/y)	Value of Conserved Energy (USD/y)	NPV (10 ³ USD)	ROI (%)	Payback Period (y)
Recover Condensable Hydrocarbons &	0.00	6,240,000	0	0	624,017	-4,076	5.11	N/A

Control Technology Type	Year Calculation Type	Estimated Emission Reduction Potential (t/y)								
		CH ₄	CO ₂	N ₂ O	CO ₂ E	VOC	CO	NO _x	SO ₂	PM
Recover Condensable Hydrocarbons & Flare Excess Residue Gas	Average	0.06	1,734	0.00	1,736	0.64	4.53	0.83	0.00	1.62
	Total	0.57	17,336	0.03	17,357	6.35	45.33	8.32	0.00	16.24
	Year-0	0.12	3,571	0.01	3,575	1.31	9.34	1.71	0.00	3.35

Control Technology Input

Device and Facility	
Clearstone Client	CCAC.3.5
Data Client	CCAC.3.5
Device Facility	CCAC.3
Device Name	CCAC.3.5
Device ID	CCAC.3.5

Economic Assumptions	
System Life (y)	10.0
Application Life (y)	10.0
Electrical Usage Rating (kWh/y)	0
Replacement Salvage Value (USD)	0
Technology EOL Salvage Value (USD)	0
Operating Cost (USD/y)	0
Operating Cost Factor	1.000
Operating Costs Avoided (USD/y)	0

Control Technology Comments
CCAC.3.5

Control Technology	
Type	Recover Condensable Hydrocarbons & Flare Excess
Combustion Type	NONE
Stream Reduction Factor (%)	0.00
Hydrocarbon Reduction Factor (%)	0.00
Sulphur Reduction Factor (%)	0.00
Application Description	Pesimistic cost

Applied Emission Factors ¹		
Substance	Value	Source
CH ₄ Emission Factor (ng/J)	N/A	
N ₂ O Emission Factor (ng/J)	N/A	
VOC Emission Factor (ng/J)	N/A	
CO Emission Factor (ng/J)	N/A	
PM Emission Factor (ng/J)	N/A	
NO _x Emission Factor (ng/J)	N/A	
HC Destruction Efficiency (%)	N/A	

¹ Emission Factors used in simulation if the Control Technology consumes fuel as part of its operation.

Property	Stream(s)
	Recovery
Temperature (°C)	15
Pressure (kPa gage)	0
Line Name	CCAC.3.5
Cross Sectional Shape	Circular
Pipe Outside Diameter (mm)	N/A
Pipe Wall Thickness (mm)	N/A
Pipe Rectangular Length (mm)	N/A
Pipe Rectangular Width (mm)	N/A
Measurement Type	Process Simulation
Reading Type	Molar Flow Rate
Measurement Date	N/A
Velocity (m/s)	---
Flow Rate (m ³ /h)	---
Standard Flow Rate (std m ³ /h)	172.907
Composition Name	CCAC.Comp.8
Composition ID	CCAC.Comp.8

Composition Source Data

Analysis Administration Data	
Name	CCAC.Comp.8
Description and Comments	CCAC.Comp.8
Creation Date	2015-11-30
Sample Date	N/A
Sample Type	Computed (Gas/Molar)
Substance Type	Unknown
Clearstone ID	CCAC.Comp.8

Analysis Results			
Component Name	Mole Fraction		
	Entered	Normalized	Air Free
Carbon dioxide	0.048202	0.048202	0.048202
Ethane	0.099997	0.099997	0.099997
Isobutane	0.103537	0.103537	0.103537
Isopentane	0.051608	0.051608	0.051608
Methane	0.015015	0.015015	0.015015
n-Butane	0.257026	0.257026	0.257026
n-Hexane	0.002519	0.002519	0.002519
Nitrogen	0.000007	0.000007	0.000007
n-Pentane	0.042687	0.042687	0.042687
Propane	0.379402	0.379402	0.379402
Total	1.000000	1.000000	1.000000

Production Decline Economics

Application Life (years)	Monetary Discount Rate (%/year)	Applied Production Decline Rate (%/year)	Assumed Inflation Rate (%/year)
10.0	10.0	15.0	0.0

Year	Revenues ¹ (USD)	Costs ¹ (USD)	Net Revenues (USD)	Net Present Value ² (USD)	ROI ³ (%)
0	0	6,240,000	-6,240,000	-6,240,000	—
1	544,929	0	544,929	495,390	8.7
1	544,929	0	544,929	495,390	8.7
1	544,929	0	544,929	495,390	8.7
1	544,929	0	544,929	495,390	8.7
2	475,865	0	475,865	393,277	7.6
2	475,865	0	475,865	393,277	7.6
2	475,865	0	475,865	393,277	7.6
2	475,865	0	475,865	393,277	7.6
3	415,554	0	415,554	312,212	6.7
3	415,554	0	415,554	312,212	6.7
3	415,554	0	415,554	312,212	6.7
3	415,554	0	415,554	312,212	6.7
4	362,886	0	362,886	247,856	5.8
4	362,886	0	362,886	247,856	5.8
4	362,886	0	362,886	247,856	5.8
4	362,886	0	362,886	247,856	5.8
5	316,894	0	316,894	196,766	5.1
5	316,894	0	316,894	196,766	5.1
5	316,894	0	316,894	196,766	5.1
5	316,894	0	316,894	196,766	5.1
6	276,731	0	276,731	156,207	4.4
6	276,731	0	276,731	156,207	4.4
6	276,731	0	276,731	156,207	4.4
6	276,731	0	276,731	156,207	4.4
7	241,658	0	241,658	124,009	3.9
7	241,658	0	241,658	124,009	3.9
7	241,658	0	241,658	124,009	3.9
7	241,658	0	241,658	124,009	3.9
8	211,030	0	211,030	98,447	3.4
8	211,030	0	211,030	98,447	3.4
8	211,030	0	211,030	98,447	3.4
8	211,030	0	211,030	98,447	3.4

9	184,284	0	184,284	78,155	3.0
9	184,284	0	184,284	78,155	3.0
9	184,284	0	184,284	78,155	3.0
9	184,284	0	184,284	78,155	3.0
10	160,928	0	160,928	62,045	2.6
10	160,928	0	160,928	62,045	2.6
10	160,928	0	160,928	62,045	2.6
10	160,928	0	160,928	62,045	2.6
Total	12,763,035	6,240,000	6,523,035	2,417,452	5.1

¹ For year 0 Costs and Revenues represent capital cost and salvage values. For other years they represent operating cost and revenues in current year dollars.

² Net Present Value is expressed in Year-0 dollars.

³ ROI is current year net revenues over capital cost in Year-0 dollars. The Total row for this column is the median ROI value over the operating years.

Capital Cost Details

Control Technology Type	Application description
Recover Condensable Hydrocarbons & Flare Excess Residue Gas	Pesimistic cost

Cost Category	Cost Item Type	Item Description	Rate (USD/Unit)	Quantity (Unit)	Line Total (USD)
Lump sum	Lump sum	Cost (\$/m3/h)	4,800.00	1,300.0	6,240,000

Total 6,240,000



Flare Analysis Information

Facility	
Clearstone Client	CCAC.4
Data Client	CCAC.4
Operator	CCAC.4
Name	CCAC.4
Location	CCAC.4
ID	CCAC.4
Category	Battery
Type	Oil Multi-Well
Government ID	CCAC.4
Operator BA Code	CCAC.4
Licensee BA Code	CCAC.4
Licensee Name	CCAC.4

Data Administration Details	
Period Start	2014-09-29
Period End	2014-10-08
Data Contact	Chris Lusena
Prepared By	Chris Lusena
Report Generated	7-Dec-2015

Device	
Name	CCAC.4.6
ID	CCAC.4.6
On Site Location	CCAC.4.6
Type	Flare Stack (Unassisted)
Service	Solution Gas Disposal
Manufacturer	N/A
Model	N/A
Model Year	N/A
Installation Date	N/A

General Analysis Data	
System Life (y)	10.0
Decline Rate ¹ (%/y)	15.0
Ambient Temperature (°C)	28.0
Ambient Pressure (kPa)	100.7
Average Wind Speed (m/s)	5.0
Met Station Height (m)	10.0
Stack Top Temperature (°C)	28.0
Knockout Drum Temp (°C)	28.0
Knockout Drum Pressure (kPag)	28.0

Device Comments and Assumptions
CCAC.4.6

¹ The applied annaly production decline rate used to reduce primary gas flows in economics assumptions, to model decline production. 0 indicates an assumption of steady flow for the systems life.

Data Comments and Assumptions
CCAC.4.6

Applied Emission Factors (ng/J)		
Substance	Value	Source
CH ₄ Emission Factor	33.10	US EPA AP-42
N ₂ O Emission Factor	0.10	US EPA AP-42
VOC Emission Factor	54.73	Calculated
CO Emission Factor	159.10	US EPA AP-42
PM Emission Factor	57.00	US EPA AP-42
NO _x Emission Factor	29.20	US EPA AP-42
HC Destruction Efficiency (%)	99.11	Calculated

Flare Stream and Stack Measurements

Property	Stream(s)
	Waste
Temperature (°C)	36.8
Pressure (kPa gage)	102.6
Line Name	CCAC.4.6
Cross Sectional Shape	Circular
Pipe Outside Diameter (mm)	113.0
Pipe Wall Thickness (mm)	6.2
Pipe Rectangular Length (mm)	N/A
Pipe Rectangular Width (mm)	N/A
Measurement Type	Inline Tracer Test
Reading Type	Flow Rate Standard Conditions
Measurement Date	N/A
Velocity (m/s)	---
Flow Rate (m ³ /h)	---
Standard Flow Rate (std m ³ /h)	6.3
Composition Name	CCAC.Comp.12
Composition ID	CCAC.Comp.12

Stack Details	
Flare End Seal Type	Unknown
Stack Outside Diameter (m)	0.11
Flare Wall Thickness (mm)	5.9
Flare Stack Height (m)	12.19
Auto-ignition	No
Pilot present	Yes
Knockout Drum Diameter (m)	N/A
Knockout Drum Length(m)	N/A

Waste Stream Composition Source Data

Analysis Administration Data	
Name	CCAC.Comp.12
Description and Comments	CCAC.Comp.12
Creation Date	2014-12-04
Sample Date	2013-03-20
Sample Type	As Sampled (Gas/Molar)
Substance Type	Process Gas
Clearstone ID	CCAC.Comp.12

Analysis Results			
Component Name	Mole Fraction		
	Entered	Normalized	Air Free
Carbon dioxide	0.212420	0.212420	0.212420
Ethane	0.093276	0.093276	0.093276
Hydrogen sulfide	0.003568	0.003568	0.003568
Isobutane	0.008429	0.008429	0.008429
Isopentane	0.004485	0.004485	0.004485
Methane	0.564001	0.564001	0.564001
n-Butane	0.026089	0.026089	0.026089
n-Hexane	0.000281	0.000281	0.000281
Nitrogen	0.011426	0.011426	0.011426
n-Pentane	0.004571	0.004571	0.004571
Propane	0.071454	0.071454	0.071454
Total	1.000000	1.000000	1.000000

Flare FuelComposition Source Data

Analysis Administration Data	
Name	CCAC.Comp.12
Description and Comments	CCAC.Comp.12
Creation Date	2014-12-04
Sample Date	2013-03-20
Sample Type	As Sampled (Gas/Molar)
Substance Type	Process Gas
Clearstone ID	CCAC.Comp.12

Analysis Results			
Component Name	Mole Fraction		
	Entered	Normalized	Air Free
Carbon dioxide	0.212420	0.212420	0.212420
Ethane	0.093276	0.093276	0.093276
Hydrogen sulfide	0.003568	0.003568	0.003568
Isobutane	0.008429	0.008429	0.008429
Isopentane	0.004485	0.004485	0.004485
Methane	0.564001	0.564001	0.564001
n-Butane	0.026089	0.026089	0.026089
n-Hexane	0.000281	0.000281	0.000281
Nitrogen	0.011426	0.011426	0.011426
n-Pentane	0.004571	0.004571	0.004571
Propane	0.071454	0.071454	0.071454
Total	1.000000	1.000000	1.000000

Flare Stack Analysis Results

Purge Gas	
Minimum Flow (m ³ /h)	0.0
Current Flow (m ³ /h)	
Excess Flow (m ³ /h)	0.0

Pilot Gas	
Minimum Flow (m ³ /h)	4.0
Current Flow (m ³ /h)	
Excess Flow (m ³ /h)	0.0

Calculated Flare Stack Gas Composition	
Component Name	Mole Fraction
Methane	0.564001
Carbon dioxide	0.212420
Ethane	0.093276
Propane	0.071454
n-Butane	0.026089
Nitrogen	0.011426
Isobutane	0.008429
n-Pentane	0.004571
Isopentane	0.004485
Hydrogen sulfide	0.003568
n-Hexane	0.000281
Total	1.000000

Flare Stack Gas	
Dew Temperature (°C)	-47.1
Optimal Conditions Dew Temperature (°C)	-47.1
Stack Liquid Formation Potential	No
Knockout Drum Liquid Formation	No
Calculated HC Destruction (%)	99.11%
Calculated VOC Emission Factor (ng/J)	54.73
Calculated Flare Gas Flow (m ³ /h)	6.3

Stack Hydrocarbon Destruction Efficiency Vs. Wind Speed

Wind Speed (m/s)	HC DE (%)
0.0	99.88
1.0	99.82
2.0	99.73
3.0	99.60
4.0	99.40
5.0	99.11
6.0	98.68
7.0	98.04
8.0	97.10
9.0	95.70
10.0	93.62
11.0	92.02
12.0	90.74
13.0	89.56
14.0	88.46
15.0	87.45
16.0	86.49
17.0	85.60
18.0	84.76
19.0	83.96
20.0	83.20

Analysis Results

Source Name	Source Tag No.	Service Type
CCAC.4.6	CCAC.4.6	Solution Gas Disposal

Year Calculation Type	Value of Fuel/Loss Stream (USD/y)	Total Product Loss Flow (m ³ /h)	Total Product Losses				
			Residue Gas (10 ³ m ³ /d)	Ethane (m ³ /d liq)	LPG (m ³ /d liq)	C ₅ + (m ³ /d)	Hydrogen (m ³ /d)
Average	5,715	3.1	0.04	0.02	0.03	0.00	0.00
Year-0	11,770	6.3	0.09	0.05	0.06	0.01	0.00

Year Calculation Type	Total (Direct and Indirect) Emissions (t/y)								
	CH ₄	CO ₂	N ₂ O	CO ₂ E	VOC	CO	NO _x	SO ₂	PM
Average	0.2	68	0.00	72	0.0	0.2	0.0	0.3	0.1
Total	2.0	679	0.00	722	0.2	1.7	0.3	2.6	0.6
Year-0	0.4	140	0.00	149	0.0	0.4	0.1	0.5	0.1

Potential Control Options

Control Technology Type	Energy Recovery Efficiency (%)	Capital Cost (USD)	Net Present Salvage Value (USD)	Net Operating Cost (USD/y)	Value of Conserved Energy (USD/y)	NPV (10 ³ USD)	ROI (%)	Payback Period (y)
None - Loses too small.	0.00	0	0	0	0	0	N/A	N/A
Recover Condensable Hydrocarbons &	0.00	8,346	0	0	5,862	12	35.91	1.72

Control Technology Type	Year Calculation Type	Estimated Emission Reduction Potential (t/y)								
		CH ₄	CO ₂	N ₂ O	CO ₂ E	VOC	CO	NO _x	SO ₂	PM
None - Loses too small.	Average	0.00	0	0.00	0	0.00	0.00	0.00	0.00	0.00
	Total	0.00	0	0.00	0	0.00	0.00	0.00	0.00	0.00
	Year-0	0.00	0	0.00	0	0.00	0.00	0.00	0.00	0.00
Recover Condensable Hydrocarbons & Flare Excess Residue Gas	Average	0.00	16	0.00	16	0.01	0.04	0.01	0.00	0.02
	Total	0.01	162	0.00	162	0.06	0.43	0.08	0.00	0.15
	Year-0	0.00	33	0.00	33	0.01	0.09	0.02	0.00	0.03

Control Technology Input

Device and Facility	
Clearstone Client	CCAC.4.6
Data Client	CCAC.4.6
Device Facility	CCAC.4
Device Name	CCAC.4.6
Device ID	CCAC.4.6

Economic Assumptions	
System Life (y)	20.0
Application Life (y)	10.0
Electrical Usage Rating (kWh/y)	0
Replacement Salvage Value (USD)	0
Technology EOL Salvage Value (USD)	0
Operating Cost (USD/y)	0
Operating Cost Factor	1.000
Operating Costs Avoided (USD/y)	0

Control Technology Comments
CCAC.4.6

Control Technology	
Type	Recover Condensable Hydrocarbons & Flare Excess
Combustion Type	NONE
Stream Reduction Factor (%)	0.00
Hydrocarbon Reduction Factor (%)	0.00
Sulphur Reduction Factor (%)	0.00
Application Description	propane refrigeration

Applied Emission Factors ¹		
Substance	Value	Source
CH ₄ Emission Factor (ng/J)	N/A	
N ₂ O Emission Factor (ng/J)	N/A	
VOC Emission Factor (ng/J)	N/A	
CO Emission Factor (ng/J)	N/A	
PM Emission Factor (ng/J)	N/A	
NO _x Emission Factor (ng/J)	N/A	
HC Destruction Efficiency (%)	N/A	

¹ Emission Factors used in simulation if the Control Technology consumes fuel as part of its operation.

Property	Stream(s)
	Recovery
Temperature (°C)	15
Pressure (kPa gage)	0
Line Name	CCAC.4.6
Cross Sectional Shape	Circular
Pipe Outside Diameter (mm)	111
Pipe Wall Thickness (mm)	1
Pipe Rectangular Length (mm)	N/A
Pipe Rectangular Width (mm)	N/A
Measurement Type	Process Simulation
Reading Type	Molar Flow Rate
Measurement Date	N/A
Velocity (m/s)	---
Flow Rate (m ³ /h)	---
Standard Flow Rate (std m ³ /h)	---
Composition Name	CCAC.Comp.11
Composition ID	CCAC.Comp.11

Composition Source Data

Analysis Administration Data	
Name	CCAC.Comp.11
Description and Comments	CCAC.Comp.11
Creation Date	2015-12-02
Sample Date	N/A
Sample Type	Computed (Gas/Molar)
Substance Type	Unknown
Clearstone ID	CCAC.Comp.11

Analysis Results			
Component Name	Mole Fraction		
	Entered	Normalized	Air Free
Ethane	0.126781	0.126781	0.126781
Isobutane	0.075414	0.075414	0.075414
Isopentane	0.044935	0.044935	0.044935
Methane	0.029849	0.029849	0.029849
n-Butane	0.244098	0.244098	0.244098
n-Hexane	0.002889	0.002889	0.002889
Nitrogen	0.000075	0.000075	0.000075
n-Pentane	0.046061	0.046061	0.046061
Propane	0.429898	0.429898	0.429898
Total	1.000000	1.000000	1.000000

Production Decline Economics

Application Life (years)	Monetary Discount Rate (%/year)	Applied Production Decline Rate (%/year)	Assumed Inflation Rate (%/year)
10.0	10.0	15.0	0.0

Year	Revenues ¹ (USD)	Costs ¹ (USD)	Net Revenues (USD)	Net Present Value ² (USD)	ROI ³ (%)
0	0	8,346	-8,346	-8,346	—
1	5,119	0	5,119	4,654	61.3
1	5,119	0	5,119	4,654	61.3
1	5,119	0	5,119	4,654	61.3
1	5,119	0	5,119	4,654	61.3
2	4,470	0	4,470	3,695	53.6
2	4,470	0	4,470	3,695	53.6
2	4,470	0	4,470	3,695	53.6
2	4,470	0	4,470	3,695	53.6
3	3,904	0	3,904	2,933	46.8
3	3,904	0	3,904	2,933	46.8
3	3,904	0	3,904	2,933	46.8
3	3,904	0	3,904	2,933	46.8
4	3,409	0	3,409	2,328	40.8
4	3,409	0	3,409	2,328	40.8
4	3,409	0	3,409	2,328	40.8
4	3,409	0	3,409	2,328	40.8
5	2,977	0	2,977	1,848	35.7
5	2,977	0	2,977	1,848	35.7
5	2,977	0	2,977	1,848	35.7
5	2,977	0	2,977	1,848	35.7
6	2,600	0	2,600	1,467	31.1
6	2,600	0	2,600	1,467	31.1
6	2,600	0	2,600	1,467	31.1
6	2,600	0	2,600	1,467	31.1
7	2,270	0	2,270	1,165	27.2
7	2,270	0	2,270	1,165	27.2
7	2,270	0	2,270	1,165	27.2
7	2,270	0	2,270	1,165	27.2
8	1,982	0	1,982	925	23.8
8	1,982	0	1,982	925	23.8
8	1,982	0	1,982	925	23.8
8	1,982	0	1,982	925	23.8

9	1,731	0	1,731	734	20.7
9	1,731	0	1,731	734	20.7
9	1,731	0	1,731	734	20.7
9	1,731	0	1,731	734	20.7
10	1,512	0	1,512	583	18.1
10	1,512	0	1,512	583	18.1
10	1,512	0	1,512	583	18.1
10	1,512	0	1,512	583	18.1
Total	119,899	8,346	111,553	72,984	35.9

¹ For year 0 Costs and Revenues represent capital cost and salvage values. For other years they represent operating cost and revenues in current year dollars.

² Net Present Value is expressed in Year-0 dollars.

³ ROI is current year net revenues over capital cost in Year-0 dollars. The Total row for this column is the median ROI value over the operating years.

Capital Cost Details

Control Technology Type	Application description
Recover Condensable Hydrocarbons & Flare Excess Residue Gas	propane refrigeration

Cost Category	Cost Item Type	Item Description	Rate (USD/Unit)	Quantity (Unit)	Line Total (USD)
Lump sum	Lump sum	prorated cost (\$/m3/h)	1,192.34	7.0	8,346

Total 8,346

Control Technology Input

Device and Facility	
Clearstone Client	CCAC.4.6
Data Client	CCAC.4.6
Device Facility	CCAC.4
Device Name	CCAC.4.6
Device ID	CCAC.4.6

Economic Assumptions	
System Life (y)	20.0
Application Life (y)	10.0
Electrical Usage Rating (kWh/y)	0
Replacement Salvage Value (USD)	0
Technology EOL Salvage Value (USD)	0
Operating Cost (USD/y)	0
Operating Cost Factor	1.000
Operating Costs Avoided (USD/y)	0

Control Technology Comments
CCAC.4.6

Control Technology	
Type	None - Loses too small.
Combustion Type	NONE
Stream Reduction Factor (%)	0.00
Hydrocarbon Reduction Factor (%)	0.00
Sulphur Reduction Factor (%)	0.00
Application Description	flow to small.

Applied Emission Factors ¹		
Substance	Value	Source
CH ₄ Emission Factor (ng/J)	N/A	
N ₂ O Emission Factor (ng/J)	N/A	
VOC Emission Factor (ng/J)	N/A	
CO Emission Factor (ng/J)	N/A	
PM Emission Factor (ng/J)	N/A	
NO _x Emission Factor (ng/J)	N/A	
HC Destruction Efficiency (%)	N/A	

¹ Emission Factors used in simulation if the Control Technology consumes fuel as part of its operation.

Production Decline Economics

Application Life (years)	Monetary Discount Rate (%/year)	Applied Production Decline Rate (%/year)	Assumed Inflation Rate (%/year)
10.0	10.0	15.0	0.0

Year	Revenues ¹ (USD)	Costs ¹ (USD)	Net Revenues (USD)	Net Present Value ² (USD)	ROI ³ (%)
0	0	0	0	0	—
1	0	0	0	0	#DIV/0!
1	0	0	0	0	#DIV/0!
1	0	0	0	0	#DIV/0!
1	0	0	0	0	#DIV/0!
2	0	0	0	0	#DIV/0!
2	0	0	0	0	#DIV/0!
2	0	0	0	0	#DIV/0!
2	0	0	0	0	#DIV/0!
3	0	0	0	0	#DIV/0!
3	0	0	0	0	#DIV/0!
3	0	0	0	0	#DIV/0!
3	0	0	0	0	#DIV/0!
4	0	0	0	0	#DIV/0!
4	0	0	0	0	#DIV/0!
4	0	0	0	0	#DIV/0!
4	0	0	0	0	#DIV/0!
5	0	0	0	0	#DIV/0!
5	0	0	0	0	#DIV/0!
5	0	0	0	0	#DIV/0!
5	0	0	0	0	#DIV/0!
6	0	0	0	0	#DIV/0!
6	0	0	0	0	#DIV/0!
6	0	0	0	0	#DIV/0!
6	0	0	0	0	#DIV/0!
7	0	0	0	0	#DIV/0!
7	0	0	0	0	#DIV/0!
7	0	0	0	0	#DIV/0!
7	0	0	0	0	#DIV/0!
8	0	0	0	0	#DIV/0!
8	0	0	0	0	#DIV/0!
8	0	0	0	0	#DIV/0!
8	0	0	0	0	#DIV/0!

9	0	0	0	0	#DIV/0!
9	0	0	0	0	#DIV/0!
9	0	0	0	0	#DIV/0!
9	0	0	0	0	#DIV/0!
10	0	0	0	0	#DIV/0!
10	0	0	0	0	#DIV/0!
10	0	0	0	0	#DIV/0!
10	0	0	0	0	#DIV/0!
Total	0	0	0	0	#DIV/0!

¹ For year 0 Costs and Revenues represent capital cost and salvage values. For other years they represent operating cost and revenues in current year dollars.

² Net Present Value is expressed in Year-0 dollars.

³ ROI is current year net revenues over capital cost in Year-0 dollars. The Total row for this column is the median ROI value over the operating years.



Flare Analysis Information

Facility	
Clearstone Client	CCAC.5
Data Client	CCAC.5
Operator	CCAC.5
Name	CCAC.5
Location	CCAC.5
ID	CCAC.5
Category	Battery
Type	Oil Multi-Well
Government ID	CCAC.5
Operator BA Code	CCAC.5
Licensee BA Code	CCAC.5
Licensee Name	CCAC.5

Data Administration Details	
Period Start	2014-09-29
Period End	2014-10-08
Data Contact	Chris Lusena
Prepared By	Chris Lusena
Report Generated	7-Dec-2015

Device	
Name	CCAC.5.7
ID	CCAC.5.7
On Site Location	CCAC.5.7
Type	Flare Stack (Unassisted)
Service	Associated Gas Disposal
Manufacturer	N/A
Model	N/A
Model Year	N/A
Installation Date	N/A

General Analysis Data	
System Life (y)	10.0
Decline Rate ¹ (%/y)	15.0
Ambient Temperature (°C)	29.0
Ambient Pressure (kPa)	100.5
Average Wind Speed (m/s)	5.0
Met Station Height (m)	10.0
Stack Top Temperature (°C)	25.0
Knockout Drum Temp (°C)	25.0
Knockout Drum Pressure (kPag)	0.0

Device Comments and Assumptions
CCAC.5.7

¹ The applied annaly production decline rate used to reduce primary gas flows in economics assumptions, to model decline production. 0 indicates an assumption of steady flow for the systems life.

Data Comments and Assumptions
CCAC.5.7

Applied Emission Factors (ng/J)		
Substance	Value	Source
CH ₄ Emission Factor	33.10	US EPA AP-42
N ₂ O Emission Factor	0.10	US EPA AP-42
VOC Emission Factor	8.95	Calculated
CO Emission Factor	159.10	US EPA AP-42
PM Emission Factor	57.00	US EPA AP-42
NO _x Emission Factor	29.20	US EPA AP-42
HC Destruction Efficiency (%)	99.81	Calculated

Flare Stream and Stack Measurements

Property	Stream(s)
	Waste
Temperature (°C)	34.4
Pressure (kPa gage)	102.3
Line Name	CCAC.5.7
Cross Sectional Shape	Circular
Pipe Outside Diameter (mm)	113.0
Pipe Wall Thickness (mm)	6.2
Pipe Rectangular Length (mm)	N/A
Pipe Rectangular Width (mm)	N/A
Measurement Type	Inline Tracer Test
Reading Type	Flow Rate Standard Conditions
Measurement Date	Oct 6 2014 4:40PM
Velocity (m/s)	---
Flow Rate (m ³ /h)	---
Standard Flow Rate (std m ³ /h)	614.9
Composition Name	CCAC.Comp.15
Composition ID	CCAC.Comp.15

Stack Details	
Flare End Seal Type	Unknown
Stack Outside Diameter (m)	0.11
Flare Wall Thickness (mm)	5.9
Flare Stack Height (m)	12.19
Auto-ignition	No
Pilot present	Yes
Knockout Drum Diameter (m)	N/A
Knockout Drum Length(m)	N/A

Waste Stream Composition Source Data

Analysis Administration Data	
Name	CCAC.Comp.15
Description and Comments	CCAC.Comp.15
Creation Date	2014-12-10
Sample Date	N/A
Sample Type	Computed (Gas/Molar)
Substance Type	Waste Gas
Clearstone ID	CCAC.Comp.15

Analysis Results			
Component Name	Mole Fraction		
	Entered	Normalized	Air Free
Carbon dioxide	0.089598	0.089598	0.089598
Ethane	0.086336	0.086336	0.086336
Isobutane	0.007467	0.007467	0.007467
Isopentane	0.006549	0.006549	0.006549
Methane	0.695377	0.695377	0.695377
n-Butane	0.020575	0.020575	0.020575
n-Hexane	0.005174	0.005174	0.005174
Nitrogen	0.045100	0.045100	0.045100
n-Pentane	0.006828	0.006828	0.006828
Propane	0.036996	0.036996	0.036996
Total	1.000000	1.000000	1.000000

Flare FuelComposition Source Data

Analysis Administration Data	
Name	CCAC.Comp.14
Description and Comments	CCAC.Comp.14
Creation Date	2014-12-04
Sample Date	2011-04-07
Sample Type	As Sampled (Gas/Molar)
Substance Type	Process Gas
Clearstone ID	CCAC.Comp.14

Analysis Results			
Component Name	Mole Fraction		
	Entered	Normalized	Air Free
Carbon dioxide	0.098490	0.098490	0.098490
Ethane	0.094905	0.094905	0.094905
Isobutane	0.008208	0.008208	0.008208
Isopentane	0.007199	0.007199	0.007199
Methane	0.665144	0.665144	0.665144
n-Butane	0.022617	0.022617	0.022617
n-Hexane	0.005687	0.005687	0.005687
Nitrogen	0.049576	0.049576	0.049576
n-Pentane	0.007506	0.007506	0.007506
Propane	0.040668	0.040668	0.040668
Total	1.000000	1.000000	1.000000

Flare Stack Analysis Results

Purge Gas	
Minimum Flow (m ³ /h)	0.0
Current Flow (m ³ /h)	
Excess Flow (m ³ /h)	0.0

Pilot Gas	
Minimum Flow (m ³ /h)	4.0
Current Flow (m ³ /h)	
Excess Flow (m ³ /h)	0.0

Calculated Flare Stack Gas Composition	
Component Name	Mole Fraction
Methane	0.695377
Carbon dioxide	0.089598
Ethane	0.086336
Nitrogen	0.045100
Propane	0.036996
n-Butane	0.020575
Isobutane	0.007467
n-Pentane	0.006828
Isopentane	0.006549
n-Hexane	0.005174
Total	1.000000

Flare Stack Gas	
Dew Temperature (°C)	-30.6
Optimal Conditions Dew Temperature (°C)	-30.6
Stack Liquid Formation Potential	No
Knockout Drum Liquid Formation	No
Calculated HC Destruction (%)	99.81%
Calculated VOC Emission Factor (ng/J)	8.95
Calculated Flare Gas Flow (m ³ /h)	614.9

Stack Hydrocarbon Destruction Efficiency Vs. Wind Speed

Wind Speed (m/s)	HC DE (%)
0.0	99.88
1.0	99.87
2.0	99.85
3.0	99.84
4.0	99.83
5.0	99.81
6.0	99.79
7.0	99.77
8.0	99.75
9.0	99.73
10.0	99.71
11.0	99.68
12.0	99.65
13.0	99.62
14.0	99.59
15.0	99.55
16.0	99.51
17.0	99.47
18.0	99.42
19.0	99.37
20.0	99.31

Analysis Results

Source Name	Source Tag No.	Service Type
CCAC.5.7	CCAC.5.7	Associated Gas Disposal

Year Calculation Type	Value of Fuel/Loss Stream (USD/y)	Total Product Loss Flow (m ³ /h)	Total Product Losses				
			Residue Gas (10 ³ m ³ /d)	Ethane (m ³ /d liq)	LPG (m ³ /d liq)	C ₅ + (m ³ /d)	Hydrogen (m ³ /d)
Average	508,947	298.5	4.98	2.20	1.82	0.67	0.00
Year-0	1,048,216	614.9	10.26	4.53	3.75	1.39	0.00

Year Calculation Type	Total (Direct and Indirect) Emissions (t/y)								
	CH ₄	CO ₂	N ₂ O	CO ₂ E	VOC	CO	NO _x	SO ₂	PM
Average	24.7	6,224	0.01	6,746	2.4	17.5	3.2	0.0	6.3
Total	246.8	62,244	0.10	67,459	24.5	174.7	32.1	0.0	62.6
Year-0	50.8	12,820	0.02	13,894	5.0	36.0	6.6	0.0	12.9

Potential Control Options

Control Technology Type	Energy Recovery Efficiency (%)	Capital Cost (USD)	Net Present Salvage Value (USD)	Net Operating Cost (USD/y)	Value of Conserved Energy (USD/y)	NPV (10 ³ USD)	ROI (%)	Payback Period (y)
Recover Condensable Hydrocarbons &	0.00	2,952,000	0	0	420,132	-1,495	7.28	N/A

Control Technology Type	Year Calculation Type	Estimated Emission Reduction Potential (t/y)								
		CH ₄	CO ₂	N ₂ O	CO ₂ E	VOC	CO	NO _x	SO ₂	PM
Recover Condensable Hydrocarbons & Flare Excess Residue Gas	Average	0.08	1,185	0.00	1,187	0.43	3.09	0.57	0.00	1.11
	Total	0.75	11,848	0.02	11,870	4.33	30.90	5.67	0.00	11.07
	Year-0	0.16	2,440	0.00	2,445	0.89	6.36	1.17	0.00	2.28

Control Technology Input

Device and Facility	
Clearstone Client	CCAC.5.7
Data Client	CCAC.5.7
Device Facility	CCAC.5
Device Name	CCAC.5.7
Device ID	CCAC.5.7

Economic Assumptions	
System Life (y)	10.0
Application Life (y)	10.0
Electrical Usage Rating (kWh/y)	0
Replacement Salvage Value (USD)	0
Technology EOL Salvage Value (USD)	0
Operating Cost (USD/y)	0
Operating Cost Factor	1.000
Operating Costs Avoided (USD/y)	0

Control Technology Comments
CCAC.5.7

Control Technology	
Type	Recover Condensable Hydrocarbons & Flare Excess
Combustion Type	NONE
Stream Reduction Factor (%)	0.00
Hydrocarbon Reduction Factor (%)	0.00
Sulphur Reduction Factor (%)	0.00
Application Description	Pesimistic cost

Applied Emission Factors ¹		
Substance	Value	Source
CH ₄ Emission Factor (ng/J)	N/A	
N ₂ O Emission Factor (ng/J)	N/A	
VOC Emission Factor (ng/J)	N/A	
CO Emission Factor (ng/J)	N/A	
PM Emission Factor (ng/J)	N/A	
NO _x Emission Factor (ng/J)	N/A	
HC Destruction Efficiency (%)	N/A	

¹ Emission Factors used in simulation if the Control Technology consumes fuel as part of its operation.

Property	Stream(s)
	Recovery
Temperature (°C)	15
Pressure (kPa gage)	0
Line Name	CCAC.5.7
Cross Sectional Shape	Circular
Pipe Outside Diameter (mm)	N/A
Pipe Wall Thickness (mm)	N/A
Pipe Rectangular Length (mm)	N/A
Pipe Rectangular Width (mm)	N/A
Measurement Type	Process Simulation
Reading Type	Molar Flow Rate
Measurement Date	N/A
Velocity (m/s)	---
Flow Rate (m ³ /h)	---
Standard Flow Rate (std m ³ /h)	48.8259
Composition Name	CCAC.Comp.13
Composition ID	CCAC.Comp.13

Composition Source Data

Analysis Administration Data	
Name	CCAC.Comp.13
Description and Comments	CCAC.Comp.13
Creation Date	2015-11-30
Sample Date	N/A
Sample Type	Computed (Gas/Molar)
Substance Type	Unknown
Clearstone ID	CCAC.Comp.13

Analysis Results			
Component Name	Mole Fraction		
	Entered	Normalized	Air Free
Carbon dioxide	0.029405	0.029405	0.029405
Ethane	0.107089	0.107089	0.107089
Isobutane	0.083205	0.083205	0.083205
Isopentane	0.093539	0.093539	0.093539
Methane	0.032527	0.032527	0.032527
n-Butane	0.252726	0.252726	0.252726
n-Hexane	0.078189	0.078189	0.078189
Nitrogen	0.000267	0.000267	0.000267
n-Pentane	0.098718	0.098718	0.098718
Propane	0.224336	0.224336	0.224336
Total	1.000001	1.000000	1.000000

Production Decline Economics

Application Life (years)	Monetary Discount Rate (%/year)	Applied Production Decline Rate (%/year)	Assumed Inflation Rate (%/year)
10.0	10.0	15.0	0.0

Year	Revenues ¹ (USD)	Costs ¹ (USD)	Net Revenues (USD)	Net Present Value ² (USD)	ROI ³ (%)
0	0	2,952,000	-2,952,000	-2,952,000	—
1	366,885	0	366,885	333,531	12.4
1	366,885	0	366,885	333,531	12.4
1	366,885	0	366,885	333,531	12.4
1	366,885	0	366,885	333,531	12.4
2	320,386	0	320,386	264,782	10.9
2	320,386	0	320,386	264,782	10.9
2	320,386	0	320,386	264,782	10.9
2	320,386	0	320,386	264,782	10.9
3	279,780	0	279,780	210,203	9.5
3	279,780	0	279,780	210,203	9.5
3	279,780	0	279,780	210,203	9.5
3	279,780	0	279,780	210,203	9.5
4	244,321	0	244,321	166,874	8.3
4	244,321	0	244,321	166,874	8.3
4	244,321	0	244,321	166,874	8.3
4	244,321	0	244,321	166,874	8.3
5	213,355	0	213,355	132,477	7.2
5	213,355	0	213,355	132,477	7.2
5	213,355	0	213,355	132,477	7.2
5	213,355	0	213,355	132,477	7.2
6	186,315	0	186,315	105,170	6.3
6	186,315	0	186,315	105,170	6.3
6	186,315	0	186,315	105,170	6.3
6	186,315	0	186,315	105,170	6.3
7	162,701	0	162,701	83,491	5.5
7	162,701	0	162,701	83,491	5.5
7	162,701	0	162,701	83,491	5.5
7	162,701	0	162,701	83,491	5.5
8	142,080	0	142,080	66,282	4.8
8	142,080	0	142,080	66,282	4.8
8	142,080	0	142,080	66,282	4.8
8	142,080	0	142,080	66,282	4.8

9	124,073	0	124,073	52,619	4.2
9	124,073	0	124,073	52,619	4.2
9	124,073	0	124,073	52,619	4.2
9	124,073	0	124,073	52,619	4.2
10	108,348	0	108,348	41,773	3.7
10	108,348	0	108,348	41,773	3.7
10	108,348	0	108,348	41,773	3.7
10	108,348	0	108,348	41,773	3.7
Total	8,592,976	2,952,000	5,640,976	2,876,808	7.3

¹ For year 0 Costs and Revenues represent capital cost and salvage values. For other years they represent operating cost and revenues in current year dollars.

² Net Present Value is expressed in Year-0 dollars.

³ ROI is current year net revenues over capital cost in Year-0 dollars. The Total row for this column is the median ROI value over the operating years.

Capital Cost Details

Control Technology Type	Application description
Recover Condensable Hydrocarbons & Flare Excess Residue Gas	Pesimistic cost

Cost Category	Cost Item Type	Item Description	Rate (USD/Unit)	Quantity (Unit)	Line Total (USD)
Lump sum	Lump sum	\$/m3/h	4,800.00	615.0	2,952,000

Total 2,952,000



Flare Analysis Information

Facility	
Clearstone Client	CCAC.6
Data Client	CCAC.6
Operator	CCAC.6
Name	CCAC.6
Location	CCAC.6
ID	CCAC.6
Category	Battery
Type	Oil Multi-Well
Government ID	CCAC.6
Operator BA Code	CCAC.6
Licensee BA Code	CCAC.6
Licensee Name	CCAC.6

General Analysis Data	
System Life (y)	10.0
Decline Rate ¹ (%/y)	15.0
Ambient Temperature (°C)	0.0
Ambient Pressure (kPa)	101.3
Average Wind Speed (m/s)	5.0
Met Station Height (m)	10.0
Stack Top Temperature (°C)	25.0
Knockout Drum Temp (°C)	25.0
Knockout Drum Pressure (kPag)	0.0

¹ The applied annaly production decline rate used to reduce primary gas flows in economics assumptions, to model decline production. 0 indicates an assumption of steady flow for the systems life.

Data Comments and Assumptions
CCAC.6.8

Data Administration Details	
Period Start	2014-09-29
Period End	2014-10-08
Data Contact	Chris Lusena
Prepared By	Chris Lusena
Report Generated	7-Dec-2015

Device	
Name	CCAC.6.8
ID	CCAC.6.8
On Site Location	CCAC.6.8
Type	Flare Stack (Unassisted)
Service	Associated Gas Disposal
Manufacturer	N/A
Model	N/A
Model Year	N/A
Installation Date	N/A

Device Comments and Assumptions
CCAC.6.8

Applied Emission Factors (ng/J)		
Substance	Value	Source
CH ₄ Emission Factor	33.10	US EPA AP-42
N ₂ O Emission Factor	0.10	US EPA AP-42
VOC Emission Factor	22.30	US EPA AP-42
CO Emission Factor	159.10	US EPA AP-42
PM Emission Factor	57.00	US EPA AP-42
NO _x Emission Factor	29.20	US EPA AP-42
HC Destruction Efficiency (%)	98.00	US EPA AP-42

Flare Stream and Stack Measurements

Property	Stream(s)
	Waste
Temperature (°C)	36.6
Pressure (kPa gage)	4.1
Line Name	CCAC.6.8
Cross Sectional Shape	Circular
Pipe Outside Diameter (mm)	113.0
Pipe Wall Thickness (mm)	6.2
Pipe Rectangular Length (mm)	N/A
Pipe Rectangular Width (mm)	N/A
Measurement Type	Inline Tracer Test
Reading Type	Flow Rate Standard Conditions
Measurement Date	Oct 8 2014 3:15PM
Velocity (m/s)	---
Flow Rate (m ³ /h)	---
Standard Flow Rate (std m ³ /h)	0.0
Composition Name	CCAC.Comp.19
Composition ID	CCAC.Comp.19

Stack Details	
Flare End Seal Type	Unknown
Stack Outside Diameter (m)	0.11
Flare Wall Thickness (mm)	5.9
Flare Stack Height (m)	12.19
Auto-ignition	No
Pilot present	Yes
Knockout Drum Diameter (m)	N/A
Knockout Drum Length(m)	N/A

Waste Stream Composition Source Data

Analysis Administration Data	
Name	CCAC.Comp.19
Description and Comments	CCAC.Comp.19
Creation Date	2014-12-10
Sample Date	N/A
Sample Type	Computed (Gas/Molar)
Substance Type	Waste Gas
Clearstone ID	CCAC.Comp.19

Analysis Results			
Component Name	Mole Fraction		
	Entered	Normalized	Air Free
Carbon dioxide	0.255839	0.255839	0.255839
Ethane	0.118923	0.118923	0.118923
Isobutane	0.015330	0.015330	0.015330
Isopentane	0.009896	0.009896	0.009896
Methane	0.392249	0.392249	0.392249
n-Butane	0.038813	0.038813	0.038813
n-Hexane	0.005209	0.005209	0.005209
Nitrogen	0.048181	0.048181	0.048181
n-Pentane	0.010390	0.010390	0.010390
Propane	0.105169	0.105169	0.105169
Total	1.000000	1.000000	1.000000

Flare FuelComposition Source Data

Analysis Administration Data	
Name	CCAC.Comp.18
Description and Comments	CCAC.Comp.18
Creation Date	2014-12-04
Sample Date	2011-11-30
Sample Type	As Sampled (Gas/Molar)
Substance Type	Process Gas
Clearstone ID	CCAC.Comp.18

Analysis Results			
Component Name	Mole Fraction		
	Entered	Normalized	Air Free
Carbon dioxide	0.231608	0.231608	0.231608
Ethane	0.107659	0.107659	0.107659
Isobutane	0.013878	0.013878	0.013878
Isopentane	0.008959	0.008959	0.008959
Methane	0.449811	0.449811	0.449811
n-Butane	0.035137	0.035137	0.035137
n-Hexane	0.004716	0.004716	0.004716
Nitrogen	0.043618	0.043618	0.043618
n-Pentane	0.009406	0.009406	0.009406
Propane	0.095208	0.095208	0.095208
Total	1.000000	1.000000	1.000000

Analysis Results

Source Name	Source Tag No.	Service Type
CCAC.6.8	CCAC.6.8	Associated Gas Disposal

Year Calculation Type	Value of Fuel/Loss Stream (USD/y)	Total Product Loss Flow (m ³ /h)	Total Product Losses				
			Residue Gas (10 ³ m ³ /d)	Ethane (m ³ /d liq)	LPG (m ³ /d liq)	C ₅ + (m ³ /d)	Hydrogen (m ³ /d)
Average	0	0.0	0.00	0.00	0.00	0.00	0.00
Year-0	0	0.0	0.00	0.00	0.00	0.00	0.00

Year Calculation Type	Total (Direct and Indirect) Emissions (t/y)								
	CH ₄	CO ₂	N ₂ O	CO ₂ E	VOC	CO	NO _x	SO ₂	PM
Average	0.0	0	0.00	0	0.0	0.0	0.0	0.0	0.0
Total	0.0	0	0.00	0	0.0	0.0	0.0	0.0	0.0
Year-0	0.0	0	0.00	0	0.0	0.0	0.0	0.0	0.0

Potential Control Options

Control Technology Type	Energy Recovery Efficiency (%)	Capital Cost (USD)	Net Present Salvage Value (USD)	Net Operating Cost (USD/y)	Value of Conserved Energy (USD/y)	NPV (10 ³ USD)	ROI (%)	Payback Period (y)
Recover Condensable Hydrocarbons &	100.00	14,400	0	0	0	-14	N/A	N/A

Control Technology Type	Year Calculation Type	Estimated Emission Reduction Potential (t/y)								
		CH ₄	CO ₂	N ₂ O	CO ₂ E	VOC	CO	NO _x	SO ₂	PM
Recover Condensable Hydrocarbons & Flare Excess Residue Gas	Average	0.00	0	0.00	0	0.00	0.00	0.00	0.00	0.00
	Total	0.00	0	0.00	0	0.00	0.00	0.00	0.00	0.00
	Year-0	0.00	0	0.00	0	0.00	0.00	0.00	0.00	0.00

Control Technology Input

Device and Facility	
Clearstone Client	CCAC.6.8
Data Client	CCAC.6.8
Device Facility	CCAC.6
Device Name	CCAC.6.8
Device ID	CCAC.6.8

Economic Assumptions	
System Life (y)	10.0
Application Life (y)	10.0
Electrical Usage Rating (kWh/y)	N/A
Replacement Salvage Value (USD)	N/A
Technology EOL Salvage Value (USD)	0
Operating Cost (USD/y)	0
Operating Cost Factor	1.000
Operating Costs Avoided (USD/y)	N/A

Control Technology Comments
CCAC.6.8

Control Technology	
Type	Recover Condensable Hydrocarbons & Flare Excess
Combustion Type	Flare Stack (Unassisted)
Stream Reduction Factor (%)	100.00
Hydrocarbon Reduction Factor (%)	0.00
Sulphur Reduction Factor (%)	0.00
Application Description	Pesimistic cost

Applied Emission Factors ¹		
Substance	Value	Source
CH ₄ Emission Factor (ng/J)	33.10	US EPA AP-42
N ₂ O Emission Factor (ng/J)	0.10	US EPA AP-42
VOC Emission Factor (ng/J)	730.72	User Entered
CO Emission Factor (ng/J)	159.10	US EPA AP-42
PM Emission Factor (ng/J)	57.00	US EPA AP-42
NO _x Emission Factor (ng/J)	29.20	US EPA AP-42
HC Destruction Efficiency (%)	92.28	User Entered

¹ Emission Factors used in simulation if the Control Technology consumes fuel as part of its operation.

Control Technology Stream Measurements

Property	Stream(s)	
	Fuel	Recovery
Temperature (°C)	15	15
Pressure (kPa gage)	0	0
Line Name	CCAC.6.8	CCAC.6.8
Cross Sectional Shape	Circular	Circular
Pipe Outside Diameter (mm)	N/A	N/A
Pipe Wall Thickness (mm)	N/A	N/A
Pipe Rectangular Length (mm)	N/A	N/A
Pipe Rectangular Width (mm)	N/A	N/A
Measurement Type	Process Simulation	Process Simulation
Reading Type	Flow Rate Standard Conditions	Flow Rate Standard Conditions
Measurement Date	N/A	N/A
Velocity (m/s)	---	---
Flow Rate (m ³ /h)	---	---
Standard Flow Rate (std m ³ /h)	0	0
Composition Name	CCAC.Comp.16	CCAC.Comp.17
Composition ID	CCAC.Comp.16	CCAC.Comp.17

Composition Source Data

Analysis Administration Data	
Name	CCAC.Comp.16
Description and Comments	CCAC.Comp.16
Creation Date	2015-10-04
Sample Date	N/A
Sample Type	Computed (Gas/Molar)
Substance Type	Unknown
Clearstone ID	CCAC.Comp.16

Analysis Results			
Component Name	Mole Fraction		
	Entered	Normalized	Air Free
Carbon dioxide	0.310322	0.310322	0.310322
Ethane	0.144248	0.144248	0.144248
Isobutane	0.000930	0.000930	0.000930
Isopentane	0.000600	0.000600	0.000600
Methane	0.475781	0.475781	0.475781
n-Butane	0.002354	0.002354	0.002354
n-Hexane	0.000316	0.000316	0.000316
Nitrogen	0.058442	0.058442	0.058442
n-Pentane	0.000630	0.000630	0.000630
Propane	0.006378	0.006378	0.006378
Total	1.000000	1.000000	1.000000

Composition Source Data

Analysis Administration Data	
Name	CCAC.Comp.17
Description and Comments	CCAC.Comp.17
Creation Date	2015-10-04
Sample Date	N/A
Sample Type	Computed (Gas/Molar)
Substance Type	Unknown
Clearstone ID	CCAC.Comp.17

Analysis Results			
Component Name	Mole Fraction		
	Entered	Normalized	Air Free
Isobutane	0.082951	0.082951	0.082951
Isopentane	0.053549	0.053549	0.053549
n-Butane	0.210019	0.210019	0.210019
n-Hexane	0.028188	0.028188	0.028188
n-Pentane	0.056221	0.056221	0.056221
Propane	0.569072	0.569072	0.569072
Total	1.000000	1.000000	1.000000

Production Decline Economics

Application Life (years)	Monetary Discount Rate (%/year)	Applied Production Decline Rate (%/year)	Assumed Inflation Rate (%/year)
10.0	10.0	15.0	0.0

Year	Revenues ¹ (USD)	Costs ¹ (USD)	Net Revenues (USD)	Net Present Value ² (USD)	ROI ³ (%)
0	0	14,400	-14,400	-14,400	—
1	0	0	0	0	0.0
1	0	0	0	0	0.0
1	0	0	0	0	0.0
1	0	0	0	0	0.0
2	0	0	0	0	0.0
2	0	0	0	0	0.0
2	0	0	0	0	0.0
2	0	0	0	0	0.0
3	0	0	0	0	0.0
3	0	0	0	0	0.0
3	0	0	0	0	0.0
3	0	0	0	0	0.0
4	0	0	0	0	0.0
4	0	0	0	0	0.0
4	0	0	0	0	0.0
4	0	0	0	0	0.0
5	0	0	0	0	0.0
5	0	0	0	0	0.0
5	0	0	0	0	0.0
5	0	0	0	0	0.0
6	0	0	0	0	0.0
6	0	0	0	0	0.0
6	0	0	0	0	0.0
6	0	0	0	0	0.0
7	0	0	0	0	0.0
7	0	0	0	0	0.0
7	0	0	0	0	0.0
7	0	0	0	0	0.0
8	0	0	0	0	0.0
8	0	0	0	0	0.0
8	0	0	0	0	0.0
8	0	0	0	0	0.0

9	0	0	0	0	0.0
9	0	0	0	0	0.0
9	0	0	0	0	0.0
9	0	0	0	0	0.0
10	0	0	0	0	0.0
10	0	0	0	0	0.0
10	0	0	0	0	0.0
10	0	0	0	0	0.0
Total	0	14,400	-14,400	-14,400	0.0

¹ For year 0 Costs and Revenues represent capital cost and salvage values. For other years they represent operating cost and revenues in current year dollars.

² Net Present Value is expressed in Year-0 dollars.

³ ROI is current year net revenues over capital cost in Year-0 dollars. The Total row for this column is the median ROI value over the operating years.

Capital Cost Details

Control Technology Type	Application description
Recover Condensable Hydrocarbons & Flare Excess Residue Gas	Pesimistic cost

Cost Category	Cost Item Type	Item Description	Rate (USD/Unit)	Quantity (Unit)	Line Total (USD)
Lump sum	Lump sum	Cost (\$/m3/h)	14,400.00	1.0	14,400

Total 14,400



Flare Analysis Information

Facility	
Clearstone Client	CCAC.7
Data Client	CCAC.7
Operator	CCAC.7
Name	CCAC.7
Location	CCAC.7
ID	CCAC.7
Category	Compressor Station
Type	Gas Transmission
Government ID	CCAC.7
Operator BA Code	CCAC.7
Licensee BA Code	CCAC.7
Licensee Name	CCAC.7

General Analysis Data	
System Life (y)	20.0
Decline Rate ¹ (%/y)	0.0
Ambient Temperature (°C)	25.0
Ambient Pressure (kPa)	101.3
Average Wind Speed (m/s)	0.0
Met Station Height (m)	10.0
Stack Top Temperature (°C)	25.0
Knockout Drum Temp (°C)	25.0
Knockout Drum Pressure (kPag)	0.0

¹ The applied annaly production decline rate used to reduce primary gas flows in economics assumptions, to model decline production. 0 indicates an assumption of steady flow for the systems life.

Data Comments and Assumptions
CCAC.7.9

Data Administration Details	
Period Start	2015-06-20
Period End	2015-07-01
Data Contact	Chris Lusena
Prepared By	Chris Lusena
Report Generated	7-Dec-2015

Device	
Name	CCAC.7.9
ID	CCAC.7.9
On Site Location	CCAC.7.9
Type	Flare Pit
Service	Continuous Waste Gas Disposal
Manufacturer	N/A
Model	N/A
Model Year	N/A
Installation Date	N/A

Device Comments and Assumptions
CCAC.7.9

Applied Emission Factors (ng/J)		
Substance	Value	Source
CH ₄ Emission Factor	33.10	US EPA AP-42
N ₂ O Emission Factor	0.10	US EPA AP-42
VOC Emission Factor	22.30	US EPA AP-42
CO Emission Factor	159.10	US EPA AP-42
PM Emission Factor	57.00	US EPA AP-42
NO _x Emission Factor	29.20	US EPA AP-42
HC Destruction Efficiency (%)	98.00	US EPA AP-42

Flare Stream and Stack Measurements

Property	Stream(s)	
	Waste	Pilot
Temperature (°C)	25.0	34.6
Pressure (kPa gage)	0.0	4.1
Line Name	CCAC.7.9	CCAC.7.9
Cross Sectional Shape	Circular	Circular
Pipe Outside Diameter (mm)	753.0	33.0
Pipe Wall Thickness (mm)	10.0	3.3
Pipe Rectangular Length (mm)	N/A	N/A
Pipe Rectangular Width (mm)	N/A	N/A
Measurement Type	Inline Tracer Test	Inline Tracer Test
Reading Type	Flow Rate Standard Conditions	Flow Rate Standard Conditions
Measurement Date	Jun 30 2015 11:45AM	Oct 3 2014 12:00AM
Velocity (m/s)	---	---
Flow Rate (m ³ /h)	---	---
Standard Flow Rate (std m ³ /h)	652.2	135.4
Composition Name	CCAC.Comp.21	CCAC.Comp.20
Composition ID	CCAC.Comp.21	CCAC.Comp.20

Stack Details	
Flare End Seal Type	Plain
Stack Outside Diameter (m)	0.75
Flare Wall Thickness (mm)	1.5
Flare Stack Height (m)	1.00
Auto-ignition	No
Pilot present	Yes
Knockout Drum Diameter (m)	N/A
Knockout Drum Length(m)	N/A

Waste Stream Composition Source Data

Analysis Administration Data	
Name	CCAC.Comp.21
Description and Comments	CCAC.Comp.21
Creation Date	2015-08-23
Sample Date	2015-06-30
Sample Type	As Sampled (Gas/Molar)
Substance Type	Unknown
Clearstone ID	CCAC.Comp.21

Analysis Results			
Component Name	Mole Fraction		
	Entered	Normalized	Air Free
Carbon dioxide	0.000000	0.000000	0.000000
Ethane	0.092134	0.092134	0.092134
Hydrogen sulfide	0.001076	0.001076	0.001076
Isobutane	0.002407	0.002407	0.002407
Methane	0.679734	0.679734	0.679734
n-Butane	0.003645	0.003645	0.003645
Nitrogen	0.161285	0.161285	0.161285
n-Pentane	0.000000	0.000000	0.000000
Propane	0.009720	0.009720	0.009720
Water	0.050000	0.050000	0.050000
Total	1.000000	1.000000	1.000000

Flare FuelComposition Source Data

Analysis Administration Data	
Name	CCAC.Comp.20
Description and Comments	CCAC.Comp.20
Creation Date	2014-12-10
Sample Date	N/A
Sample Type	As Sampled (Gas/Molar)
Substance Type	Fuel Gas
Clearstone ID	CCAC.Comp.20

Analysis Results			
Component Name	Mole Fraction		
	Entered	Normalized	Air Free
Carbon dioxide	0.000820	0.000820	0.000820
Ethane	0.085050	0.085051	0.085051
Isobutane	0.000490	0.000490	0.000490
Isopentane	0.000160	0.000160	0.000160
Methane	0.863010	0.863019	0.863019
n-Butane	0.000900	0.000900	0.000900
n-Hexane	0.000080	0.000080	0.000080
Nitrogen	0.042360	0.042360	0.042360
n-Pentane	0.000160	0.000160	0.000160
Propane	0.006960	0.006960	0.006960
Total	0.999990	1.000000	1.000000

Analysis Results

Source Name	Source Tag No.	Service Type	Value of Fuel/Loss Stream (USD/y)	Total Product Loss Flow (m ³ /h)	Total Product Losses				
					Residue Gas (10 ³ m ³ /d)	Ethane (m ³ /d liq)	LPG (m ³ /d liq)	C ₅ + (m ³ /d)	Hydrogen (m ³ /d)
CCAC.7.9	CCAC.7.9	Continuous Waste Gas Disposal	711,533	787.6	13.44	6.10	1.06	0.01	0.00

Total (Direct and Indirect) Emissions (t/y)								
CH ₄	CO ₂	N ₂ O	CO ₂ E	VOC	CO	NO _x	SO ₂	PM
66.6	12,101	0.02	13,506	5.3	37.9	7.0	16.7	13.6

Potential Control Options

Control Technology Type	Energy Recovery Efficiency (%)	Capital Cost (USD)	Net Present Salvage Value (USD)	Net Operating Cost (USD/y)	Value of Conserved Energy (USD/y)	NPV (10 ³ USD)	ROI (%)	Payback Period (y)
Pilot Gas Optimization	19.00	180,000	0	0	135,191	971	75.11	1.33
Purge Gas Optimization	76.00	2,692,800	0	69,891	540,765	1,316	17.49	5.72

Control Technology Type	Estimated Emission Reduction Potential (t/y)								
	CH ₄	CO ₂	N ₂ O	CO ₂ E	VOC	CO	NO _x	SO ₂	PM
Pilot Gas Optimization	12.65	2,299	0.00	2,566	1.01	7.21	1.32	3.16	2.58
Purge Gas Optimization	50.59	8,569	0.01	9,636	4.04	28.83	5.29	12.66	10.33

Control Technology Input

Device and Facility	
Clearstone Client	CCAC.7.9
Data Client	CCAC.7.9
Device Facility	CCAC.7
Device Name	CCAC.7.9
Device ID	CCAC.7.9

Economic Assumptions	
System Life (y)	20.0
Application Life (y)	20.0
Electrical Usage Rating (kWh/y)	1,386,030
Replacement Salvage Value (USD)	0
Technology EOL Salvage Value (USD)	0
Operating Cost (USD/y)	0
Operating Cost Factor	1.000
Operating Costs Avoided (USD/y)	0

Control Technology Comments
CCAC.7.9

Control Technology	
Type	Purge Gas Optimization
Combustion Type	NONE
Stream Reduction Factor (%)	76.00
Hydrocarbon Reduction Factor (%)	0.00
Sulphur Reduction Factor (%)	0.00
Application Description	Pesimistic cost

Applied Emission Factors ¹		
Substance	Value	Source
CH ₄ Emission Factor (ng/J)	N/A	
N ₂ O Emission Factor (ng/J)	N/A	
VOC Emission Factor (ng/J)	N/A	
CO Emission Factor (ng/J)	N/A	
PM Emission Factor (ng/J)	N/A	
NO _x Emission Factor (ng/J)	N/A	
HC Destruction Efficiency (%)	N/A	

¹ Emission Factors used in simulation if the Control Technology consumes fuel as part of its operation.

Capital Cost Details

Control Technology Type	Application description
Purge Gas Optimization	Pesimistic cost

Cost Category	Cost Item Type	Item Description	Rate (USD/Unit)	Quantity (Unit)	Line Total (USD)
Lump sum	Lump sum	Cost (\$/m3/h)	4,800.00	561.0	2,692,800

Total 2,692,800

Control Technology Input

Device and Facility	
Clearstone Client	CCAC.7.9
Data Client	CCAC.7.9
Device Facility	CCAC.7
Device Name	CCAC.7.9
Device ID	CCAC.7.9

Economic Assumptions	
System Life (y)	20.0
Application Life (y)	20.0
Electrical Usage Rating (kWh/y)	0
Replacement Salvage Value (USD)	0
Technology EOL Salvage Value (USD)	0
Operating Cost (USD/y)	0
Operating Cost Factor	1.000
Operating Costs Avoided (USD/y)	0

Control Technology Comments
CCAC.7.9

Control Technology	
Type	Pilot Gas Optimization
Combustion Type	NONE
Stream Reduction Factor (%)	19.00
Hydrocarbon Reduction Factor (%)	0.00
Sulphur Reduction Factor (%)	0.00
Application Description	Conversion to Low Consumption Pilot

Applied Emission Factors ¹		
Substance	Value	Source
CH ₄ Emission Factor (ng/J)	N/A	
N ₂ O Emission Factor (ng/J)	N/A	
VOC Emission Factor (ng/J)	N/A	
CO Emission Factor (ng/J)	N/A	
PM Emission Factor (ng/J)	N/A	
NO _x Emission Factor (ng/J)	N/A	
HC Destruction Efficiency (%)	N/A	

¹ Emission Factors used in simulation if the Control Technology consumes fuel as part of its operation.

Capital Cost Details

Control Technology Type	Application description
Pilot Gas Optimization	Conversion to Low Consumption Pilot

Cost Category	Cost Item Type	Item Description	Rate (USD/Unit)	Quantity (Unit)	Line Total (USD)
Construction	Other Constuction Cost	Installation	10,000.00	9.0	90,000
Material	Miscellaneous Material Cost	High Efficiency Pilot	10,000.00	9.0	90,000

Total 180,000

Data File Uses

Measurement Campaign	Data File Name and Id	Data File Use	Comment
2015 - Flare Gas Reduction Study	CB-104A Composition / 16	CB104aComp	The composition from AIT-1309 data assuming the remaining is nitrogen

Found Values

Simulation Data Format

Data File Use	Primary Dependant Data Field / Intermediate Value	Simulation Datum / Intermediate Value	Value	Standard Error (%)	Min	Max	Count	Standard Deviation
CB104aComp	No Field Used	nitrogen	1.61E-01	0.00	0.00E+00	0.00E+00	0	0.00E+00
		water	5.00E-02	0.00	0.00E+00	0.00E+00	0	0.00E+00
	CO2	carbon_dioxide	0.00E+00	0.00	0.00E+00	0.00E+00	1,906	0.00E+00
	Ethane	ethane	9.21E-02	0.01	9.12E-02	9.32E-02	1,906	5.00E-04
	H2S	hydrogen_sulfide	1.08E-03	1.64	0.00E+00	5.80E-03	1,906	7.72E-04
	lButane	isobutane	2.41E-03	0.46	1.80E-03	3.70E-03	1,906	4.88E-04
	Methane	methane	6.80E-01	0.01	6.74E-01	6.83E-01	1,906	2.60E-03
	nButane	n-butane	3.64E-03	0.77	2.40E-03	6.70E-03	1,906	1.23E-03
	Pentane	n-pentane	0.00E+00	0.00	0.00E+00	0.00E+00	1,906	0.00E+00
	Propane	propane	9.72E-03	0.04	9.40E-03	1.03E-02	1,906	1.67E-04

Data File Use

CB104aComp

Data Applications

Simulation Data Format

Simulation Datum / Intermediate Value	Data Field	Expression
carbon_dioxide	CO2	FieldValueZero/100.0
ethane	Ethane	FieldValueZero/100.0
hydrogen_sulfide	H2S	FieldValueZero/100.0
isobutane	lButane	FieldValueZero/100.0
methane	Methane	FieldValueZero/100.0
n-butane	nButane	FieldValueZero/100.0
nitrogen	No Field Used	Property["methane"].Value.Value*-1.0-Property["ethane"].Value.Value-Property["propane"].Value.Value-Property["isobutane"].Value.Value-Property["n-butane"].Value.Value-Property["n-pentane"].Value.Value-Property["water"].Value.Value-Property["carbon_dioxide"].Value.Value-Property["hydrogen_sulfide"].Value.Value+1.0
n-pentane	Pentane	FieldValueZero/100.0
propane	Propane	FieldValueZero/100.0
water	No Field Used	0.05

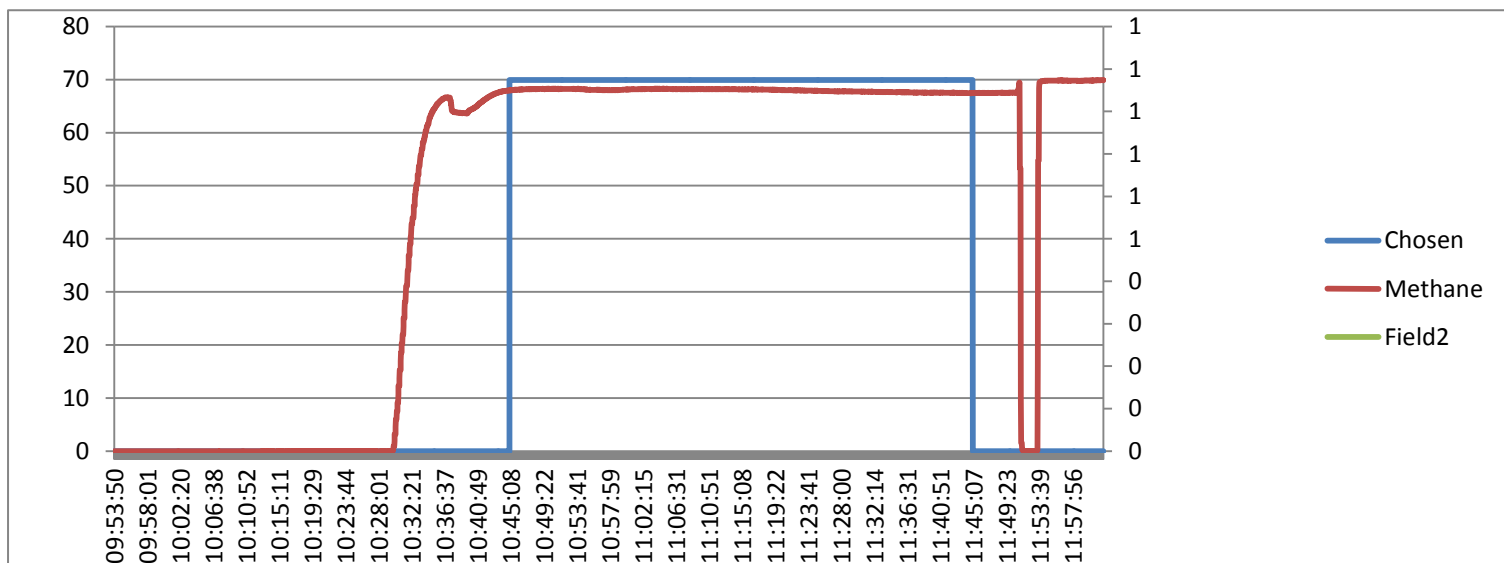

9 APPENDIX - STORAGE TANKS

9.1 INTRODUCTION

The purpose of storage tanks at production facilities, natural gas processing plants and crude oil pipeline terminals is to provide temporary storage of the produced hydrocarbon liquids (i.e., oil or condensate) and water.

Typical storage tanks operate at approximately atmospheric pressure and may include some vapour controls. Storage tanks include fixed-roof, internal floating-roof and external floating-roof designs. Tank selection and vapour controls are based on the type of fluid(s) or product(s) the tank will receive. Fluids are characterized by their Reid vapour pressure, operating temperature, composition and trace contaminants. Other considerations include the potential for dissolved gases to be contained in the fluid when it is transferred into the tank.

Atmospheric emissions from storage tanks comprise normal evaporation losses due to breathing and working effects, flashing losses when the received liquids have an initial vapour pressure close to or greater than local atmospheric pressure and potentially unintentional gas carry-through to the storage tanks. Flashing losses can be a major source of methane and VOC emissions at production facilities. Unintentional gas carry-through is less recognized, potentially significant and often an unaccounted for contributions to atmospheric emissions of hydrocarbon vapours from storage tanks, which may be caused by the following:

- Leakage of process gas or volatile product past the seats of drain or blowdown valves into the product header leading to the tanks.
- Leakage of purge gas into drain lines equipped with a purge gas system.
- Inefficient separation of gas and liquid phases upstream of the tanks allowing some gas carry-through (by entrainment) to the tanks. This usually occurs where inlet liquid production (e.g., produced water) has increased significantly over time resulting in a facility's inlet separators being undersized for current conditions.
- Piping changes resulting in the unintentional placement of high vapor pressure product in tanks not equipped with appropriate vapor controls.
- Displacement of large volumes of gas to storage tanks during pigging operations.
- The formation of a vortex at the drain on a vessel that is sending liquids to the storage tank(s).

9.2 STORAGE LOSS DETERMINATION

The preferred approach to assess atmospheric emissions from storage tanks is to apply a suitable measurement technique and continuously monitor the amount of emissions for a sufficient period of time to fully characterize the variability in the emissions (i.e., to determine the minimum, maximum and average emission rates). Ideally, the determined emissions are then related to the tank activity levels at the time of the measurement (i.e., throughput and net liquid level movement) so that the results can then be extrapolated using historical production accounting data.

If measurements are impracticable or unsafe to perform, or if the tank receives a weathered or stabilized product resulting in reduced emissions, then estimates are developed using appropriate models or simulation tools coupled with available operating data and fluid analyses.

The applicable measurement and estimation approaches are delineated below according to the type of application. The actual method applied to each tank is indicated in the detailed survey results presented at the end of this appendix.

9.2.1 EVAPORATION LOSSES FROM WEATHERED OR STABILIZED PRODUCTS

Emissions from tanks containing weathered or stabilized hydrocarbon liquids are estimated using the U.S. EPA's [TANKS](#) model, Version 4.09D. This model estimates emissions from weathered or stabilized products due to normal evaporation losses caused by breathing (or standing) and working effects.

The TANKS program is designed to estimate emissions of organic chemicals from both fixed-roof and floating-roof storage tanks. The calculations are performed using empirical correlations and methodologies developed by the American Petroleum Institute and delineated in U.S. EPA's AP-42. After the user provides specific information concerning a storage tank and its liquid contents, the system produces a report which estimates the chemical emissions for the tank on an annual or partial year basis.

Breathing losses occur when the vapours are expelled from the tank due to changes in the pressure and temperature of the vapour (usually caused by changes in the weather). This type of loss is most important during long standing periods. Working losses occur when vapours from the tank are displaced by incoming liquids (i.e., filling losses) or wetted surfaces are exposed during lowering of the liquid level (i.e., emptying losses).

The required input data for the model are collected during the field survey. This information includes tank diameter, height, and working volume, tank roof type, tank

colour, the set points on any pressure-vacuum safety valves, density and Reid vapor pressure of the weathered or stabilized hydrocarbon liquids stored in the tank, annual production rates, details on the liquid level changes during any emissions measurements performed on the tank, details on any vapor controls provided on the tank, local annual-average and monthly-average temperatures, annual-average wind speed and annual-average solar insolation factor, and local atmospheric pressure. If some meteorological data of the surveyed area are unknown, recommended data from cities in the US with similar climates are used for modeling purposes.

The Reid vapour pressure and the molecular weight of vapour and liquid, if unavailable, are estimated based on Clearstone Engineering Ltd.’s crude oil property database.

9.2.2 FLASHING LOSSES

Flashing losses occur when the produced hydrocarbon liquid has a vapor pressure greater than local atmospheric pressure. The vapour that flashes from the product in going to a "stable" state is referred to as solution gas. The amount of solution gas emissions depends on the change in vapour pressures and is directly proportional to the amount of hydrocarbon liquid produced. Where flashing losses occur, they are usually the most dominant type of storage loss.

The range of measurement and estimation techniques that may be considered to quantify flashing losses is delineated in Table 23 below. The actual method applied for each surveyed tank is identified in the detailed analysis results presented at the end of this appendix. The following subsections provide a more detailed discussion of the primary approaches.

Methodology		Applicability	Description
Primary Category	Subcategory		
Direct Measurement	Ultrasonic Flow Meter	Tank Vents	Total flow from the end of the vent is captured and routed through a transit-time ultrasonic flow meter cell.
	Velocity Traverse	Tank Vents	A suitable velocity probe is used to measure the flow velocity at selected points across the diameter of the vent outlet, and the results are integrated over the cross-sectional flow area.
	Calibrated Bag	Tank Vents	The flow rate is determined by measuring the time required to fill a durable anti-static plastic bag of known volume.
Estimation	Process Simulation	Tank Vents	If the process operating conditions are known then it may be possible to accurately predict the amount of emissions using

Table 23: Summary listing of potential methodologies for determining vent and flare rates.

Methodology		Applicability	Description
Primary Category	Subcategory		
			rigorous process simulators.
	Empirical Correlation	Tank Vents	This may be possible where vented or flared rates correlate with equipment or process unit activity levels, and the correlations and activity data are available.
	Engineering Judgment	Tank Vents	This may involve observing the source using a hydrocarbon gas/vapour-imaging camera and estimating the amount of venting based on known vent rates for other sources with similar characteristics.

9.2.2.1 DIRECT MEASUREMENTS

The emissions from the tank are typically measured using a transit-time ultrasonic flow meter installed on a short flow cell featuring an inline flow straightener. The flow cell is connected to the tank vent using flexible hydrocarbon-resistant gas/vapour-tight ducting or hose. This type of flow meter imposes essentially zero backpressure on the tank vent.

The tank activity levels at the time of the measurement are either determined from process data available from the operator, or are determined using camp-on transit-time or Doppler flow meters to measure the flow of liquids into and out of the tank. A microwave radar system may be temporarily installed on the thief hatch to continuously measure the changes in liquid level in the tank. The readings from all of these sensors are continuously data logged and transmitted wirelessly to a base station for real-time trend analysis. The measurements are performed for sufficient time to characterize the observed variations in emission rates (e.g., for 1 hour or more).

In applications where the vent is too large to connect the flow cell, then point-in-time measurements are performed by conducting a velocity traverse across the tank vent using a micro-tip vane anemometer in accordance with [US EPA Method 1A](#). Replicate sets of measurements are performed to help assess the variability in the flow.

If there are multiple vents on a tank and not all of these can be directly accessed to perform an emissions measurement, then the gas exit velocity from the inaccessible openings is assumed to be the same as the exit velocity at the accessible openings, and the flows from the inaccessible vents are determined based on these velocities and the sizes of the vent outlets. The dimensions of each vent outlet are measured using a tape

measure, where the vent is accessible; otherwise, they are determined based on the tank design details or using photographic scaling techniques if such details are unavailable.

All measured flows are corrected to standard reference conditions of 15°C and 101.325 kPa. The vapour temperature is measured using a thermocouple and local barometric pressure is either measured using an electro barometer or referenced from readings available at the closest meteorological station.

9.2.2.2 ESTIMATION TECHNIQUES

The amount of flashing losses is estimated based on a rigorous simulation of the process and product characteristics using the best available site-specific process operating data, fluid analyses and the basic process flow diagram. The process operating data may include operating temperature and pressure of all process vessels that supply hydrocarbon liquids to the storage tanks, the temperature, density and Reid vapour pressure of the final weathered liquid hydrocarbons leaving the tanks, and the total production rate of the final weathered hydrocarbon liquids and process sales gas.

The simulations are performed using Clearstone Engineering Ltd's proprietary process simulator, CSimOnline. The basic calculations involve determining the amount of liquid product that volatilizes in going from the first upstream pressure vessel to the product's final weathered state observed at the tank outlet. The minimum information needed to perform these calculations is data on the operating temperature and pressure of the upstream vessel, the hydrocarbon liquid production rate, the temperature of the sales oil or condensate and the type of product (i.e., condensate, light oil, medium oil, or heavy oil). In these cases, the model applies an appropriate reference system to determine how much gas is in solution with the oil at the upstream pressure vessel and what the weathered state of the final product will be given the type of product and its temperature.

If more detailed data such as the composition of the oil, associated gas and vapours are known then this will be used by the simulator instead of the reference fluid to perform a more rigorous determination of the flashing losses.

The actual data used in the simulation and the basis or source of the information is indicated in the detailed simulation results presented at the end of this appendix.

9.2.3 UNINTENTIONAL GAS CARRY-THROUGH

Checks are performed, where possible, to detect and, if present, quantify any unintentional gas carry-through to each surveyed storage tank. If product enters the tank in batches (e.g., the upstream pressure vessel has on/off liquid control), and there is

noteworthy emissions between dumping events then this is a clear indication of unintentional gas carry-through. The amount of unintentional gas carry through can be taken as the emission rate observed between dumping events.

If the upstream pressure vessel has proportional liquid-level control then the occurrence of unintentional gas carry-through is more difficult to detect. The only reliable means of detecting and quantifying any unintentional gas carry-through in these cases is by comparing the results of direct measurements to estimated values determined from rigorous process simulations for the given conditions and activity levels. If unintentional gas carry-through is occurring then the measured emissions will be significantly greater than the predicted emissions, and the difference will be the amount of unintentional gas carry-through to the storage tank.

9.2.4 BLANKET GAS EMISSIONS

Tanks that are equipped with natural gas blanketing will feature pressure vacuum safety valves (PVSVs) and possibly a vapour collection system and end control device (e.g., a flare or vapour recovery compressor). During normal operations, the blanket gas will enter the tank when the liquid level or pressure in the tank decreases and will stop when the pressure in the tank vapour space reaches a certain set point value. If the pressure starts to rise (e.g., due to atmospheric temperature changes or rising liquid levels), the tank will vent a mixture of blanket gas and product vapours until the pressure drops to a predetermined set point.

If there is no vapour collection system, the vented gas will be discharged directly to the atmosphere through the PVSVs. If the tank is equipped with a vapour collection system then gas will vent into the vapour collection system and there should be no emissions from the PVSVs.

During the site visit details of any natural gas blanketing system and vapour collection and control system are collected. This generally involves getting copies of the system design specifications and process and instrumentation diagram from the facility's data books, checking for signs of any emissions due to malfunctioning components, inadequate sizing of these systems or unintentional gas carry-through to the tanks. Typically, the tank is checked for any emissions from the roof top fittings, the amount of emissions is measured and the liquid level changes in the tank during the measurements are determined and used to correct the measurement results.

If there are emissions occurring, the objective is to determine if these are intentional and if the amount of emissions is normal based on the system design. If the emissions are unintentional or the emission rates are abnormal, then the potential causes of the

emissions or excess emissions are determined. Problems to check for include the following:

- Improper set-points or operation of the blanket gas regulator. This can be determined by monitoring the pressure in the head space of the tank and determining when blanket gas regulator is opening and closing versus when it is suppose to be opening and closing.
- Fouling of the PVSVs causing them to stick open.
- Excessive backpressure on the tank due to fouling of the vapour collections system (e.g., due to liquid accumulation in low spots or build-up of scale) or restrictions imposed by the end control device (e.g., an undersized vapour recovery compressor).

Where the emissions from the tank are intentional, they will be equal to the amount of blanket gas consumption plus the amount of product evaporation losses.

9.2.4.1 DIRECT MEASUREMENT

Where practicable to do, the amount of emissions is determine by direct measurement (i.e., using a transit-time ultrasonic flow meter as noted in Table 11). The measurements results give the total emissions (i.e., product vapour losses plus the blanket gas losses). If the composition of the blanket gas and the commingled blanket gas and product vapour mixture are accurately known, then it is often possible to correct the emitted gas composition to a blanket-gas free basis using the following relation, provided that the blanket gas contains a suitable reference compound that is present in the blanket gas in large concentrations but is either not present in the product vapours or only present in very trace or negligible amounts (for example, methane is often a good reference compound if the blanket gas is natural gas and the product is weathered or stabilized) :

$$\begin{aligned}
 y'_{V_i} &= y_{EG_i} - y_{BG_i} \cdot \frac{y_{EG_r}}{y_{BG_r}}, & \text{for } i = 1, N \\
 &= 0, & \text{if } y'_{V_i} < 0
 \end{aligned}$$

Equation 37

Where,

y'_{V_i} = un-normalized mole fraction of component i in the product vapour (kmole/kmole).

- y_{EG_i} = mole fraction of component i in emitted gas (kmole/kmole).
 y_{BG_i} = mole fraction of component i in blanket gas (kmole/kmole).
 y_{EG_r} = mole fraction of reference component r in emitted gas (kmole/kmole).
 y_{BG_r} = mole fraction of reference component r in blanket gas (kmole/kmole).
 N = number of components present in the emitted gas (dimensionless).

The determined vapour composition must then be normalized to correct any inconsistencies using the following relation:

$$y_{V_i} = \frac{y'_{V_i}}{\sum_{i=1}^{i=N} y'_{V_i}}$$

Equation 38

Once the normalized vapour composition has been determined then the total emissions of blanket gas alone is determined using the following relation:

$$Q_{BG} = Q_{EG} \cdot \left(1 - \sum_{i=1}^{i=N} y'_{V_i} \right)$$

Equation 39

And it follows that the amount of product vapour emitted is given by the following relation:

$$Q_V = Q_{EG} - Q_{BG}$$

Equation 40

9.2.5 ESTIMATION TECHNIQUES

The estimation approach only applies where the stored product is a weathered or stabilized product. In such cases the amount of evaporation losses is calculated using the US EPA's TANKS model. This model assumes that the product is evaporating into an air-filled ullage space rather than a blanket gas-filled ullage space. So, the results from the TANKS model are adjusted afterwards to include the blanket gas contributions; this is done using the following relation:

$$Q_{BG} = Q_V \cdot \frac{y_{BG}}{y_V}$$

Equation 41

Where,

- Q_{BG} = volumetric emission rate of blanket gas (m³/h).
 Q_V = volumetric emission rate of product vapour as determined using the US EPA TANKS model (m³/h).
 y_{BG} = mole fraction of blanket gas in the ullage space of the storage tank (mole/mole).
 y_V = mole fraction of product vapour in the ullage space of the storage tank (mole/mole).

9.3 VAPOUR ANALYSIS

The vapour composition is important for determining the commodity value of the gas and for evaluating potential control options. The amount of condensable non-methane hydrocarbons in the vapours will add greatly to the economic value of these losses and improve the economics of potential control options.

The vapour composition is determined based on one of the following methods (the actual method applied is indicated in the detailed test results provided at the end of this appendix):

- Sampling and analysis.
- Estimation based on rigorous process simulations.
- Application of typical vapour speciation profiles for hydrocarbon liquids having similar densities and sulphur content.

Normally, the vapour analyses are performed onsite using a field-deployable optical gas chromatograph (GC) or a micro-GC fitted with a thermal conductivity detector and potentially, depending on the unit, a flame ionization detector for enhanced detection and speciation capabilities. Otherwise, the samples are sent to a local laboratory, site-specific analyses are provided by the site, estimates are developed based on rigorous process simulations, or a reasonable analogue is applied.

The actual basis for the applied fluid compositions is indicated in the detailed survey results presented at the end of this appendix.

9.4 CONTROL OPTIONS

9.4.1 TANKS CONTAINING WEATHERED OR STABILIZED PRODUCT

The primary options for controlling emissions from storage tanks receiving weathered or stabilized hydrocarbon liquid products are as follows:

- Minimize the volatility of the product being placed in the storage tank (e.g., optimize the operating temperature and pressure of any upstream separators and stabilizers, or install a stabilizer if one does not already exist).
- Install floating roofs to minimize the exposed liquid surface area. Floating roofs typically provide a control efficiency of 90 percent or better and are limited to application involving products having a true vapour pressure less than 76 kPa at storage tank conditions. Floating roofs become very inefficient at greater vapour pressures and could become damaged and/or sink in the presence of excessive flashing losses. Although not quite as effective as a refined floating roof, floating tiles can be easily installed in small diameter tanks to serve as a floating roof, or can be installed in larger diameter tanks as a low-cost alternative to a refined floating-roof design.

9.4.2 TANKS CONTAINING UNWEATHERED OR UNSTABILIZED PRODUCTS

Tanks receiving products having a true vapour pressure greater than 76 kPa should be equipped with a vapour collection and treatment or recovery system. An alternative to installing a vapour collection system on each tank is to install a vapour recovery tower and simply capture the vapours from the tower rather than from each tank. Figure 12 shows a photograph of a typical vapour recovery tower designed by [Hy-Bon Engineering Company, Inc.](#) A piping and instrumentation (P&ID) diagram of a complete vapour recovery system featuring a vapour recovery tower is presented in Figure 13. The vapour recovery tower is designed to let the oil depressurize to near atmospheric pressure while retaining sufficient hydrostatic head to allow the oil to flow by gravity to the tank farm. Thus, vapours need only be collected from the top of the vapour recovery tower rather than from each individual tank. If the collected vapours are sent to a treatment system this will reduce air pollution but no economic value is realized. Ideally, the collected vapours should be commingled with the associated gas at the site and be conserved or utilized for fuel on site. The vapours from the storage tanks will tend to be richer in non-methane hydrocarbons than the associated gas and therefore will help to enrich the associated gas.

The vapour collection system and recovery or treatment system should be designed to handle peak instantaneous flow rates of vapours from the tanks. The following are

measures that should be considered to minimize these peak flows and thereby reduce the required size and cost of the vapour control system:

- **Automation of Plunger-lift Wells to Avoid Simultaneous Dumps to Separators** – At Facilities equipped with automation on two (2) or more wells, undertake appropriate operational and engineering measures to ensure that no more than one well at one time dumps into a common separator.
- **Convert from On/Off Liquid Level Control on the Separators** – if liquid flow to the separator is continuous rather than intermittent then use proportional liquid level control.
- **Adjust the Dump Valve Trim** – if on/off liquid level control is used on the separator then adjust the trim in the dump valve to achieve the maximum tolerable flow impedance.
- **Minimize the Separator Operating Pressure** – this may introduce the need for onsite compression for conservation of the associated gas production.

Other important design considerations include:

- Selection of corrosion resistant materials to reduce the potential for fouling of the piping and control device.
- Account for flashing losses, working losses and, on larger tanks, the effects of diurnal temperature changes.
- Avoid low-point liquid accumulation in the vapour collection piping.
- Where applicable, design against freezing.
- Provide adequate flame flashback protection.
- Consider installing vortex breakers on the separators to help prevent unintentional gas carry-through to the storage tanks.



Figure 12: A photograph of a typical vapour recovery tower elevated above the storage tank.

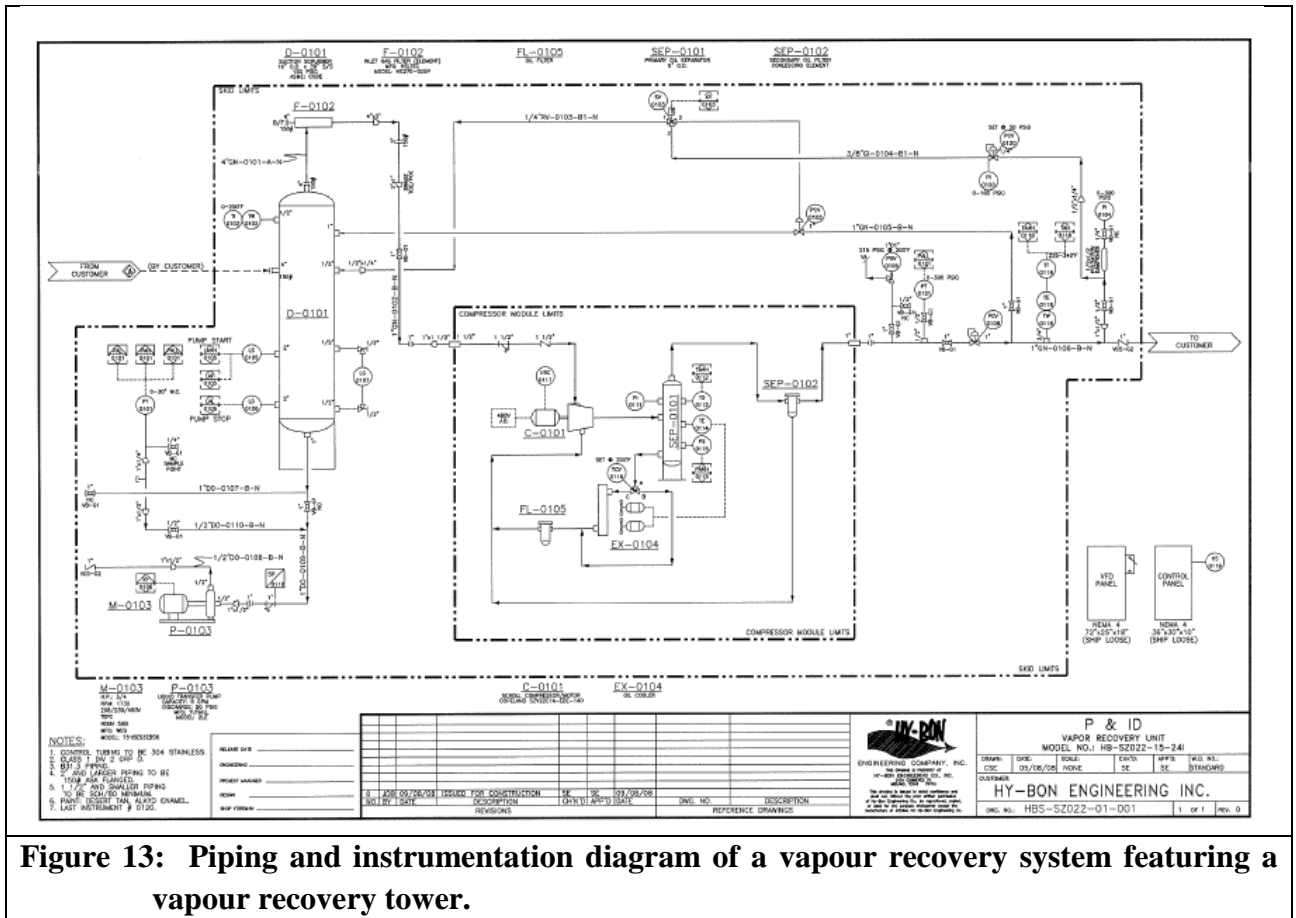

Figure 13: Piping and instrumentation diagram of a vapour recovery system featuring a vapour recovery tower.

Typical system monitoring and maintenance considerations are as follows:

- The thief hatches and pressure-vacuum relief valves (PVRVs) are high maintenance items and can be significant sources of vapour and blanket gas losses. Consequently, these need to be well maintained and regularly monitored.
- The PVRVs should be monitored for indications of pressure relief events. Such events are an indication of either system fouling causing restriction of the flow capacity of the vapour collection system or an undersized system. Pressure relief events can be detected by installing a flow switch or hydrocarbon gas sensor on the pressure relief vent line and continuously monitor their readings. There may also be visual signs such as staining of the tank roof due to frequent relief events.
- Monitor pressure losses through the system to detect fouling of the flame or detonation arrestor, or possible plugging of the piping (e.g., due to the accumulation of corrosion products, wax build-up and liquid accumulation). This can be done by monitoring differential pressures across the flame and detonation arrestor as well as peak pressures in the ullage space of the storage tank, and comparing the results to design or baseline values.

9.5 REFERENCES CITED

CAPP. 2004. *A National Inventory of Greenhouse Gas (GHG), Criteria Air Contaminant (CAC) and Hydrogen Sulphide (H₂S) Emissions by the Upstream Oil and Gas Industry, Volume 4, Methodology for CAC and H₂S Emissions*. Canadian Association of Petroleum Producers Publication No.: 2005-0014, <http://www.capp.ca/getdoc.aspx?DocId=86224&DT=NTV>

U.S. EPA. 1995b. *Compilation of Air Pollutant Emission Factors. Volume I: Stationary Point and Area Sources*. NTIA. Springfield VA. Publication No. PB95-196028. Fifth Edition and Supplements.

9.6 RESULTS

The detailed measurement and calculation results for the surveyed storage tanks are presented below:



Tanks Index

Device	Facility	Device Category	Device Type
CCAC.1.12	CCAC.1	Tanks	Fixed Roof
CCAC.3.10	CCAC.3	Tanks	Fixed Roof
CCAC.4.14	CCAC.4	Tanks	Fixed Roof
CCAC.5.13	CCAC.5	Tanks	Fixed Roof
CCAC.6.11	CCAC.6	Tanks	Fixed Roof



Tank Analysis Information

Facility	
Clearstone Client	CCAC.1
Data Client	CCAC.1
Operator	CCAC.1
Name	CCAC.1
Location	CCAC.1
ID	CCAC.1
Category	Battery
Type	Oil Multi-Well
Government ID	CCAC.1
Operator BA Code	CCAC.1
Licensee BA Code	CCAC.1
Licensee Name	CCAC.1

Data Administration Details	
Period Start	2014-09-29
Period End	2014-10-08
Data Contact	Chris Lusena
Prepared By	Chris Lusena
Report Generated	7-Dec-2015

Device	
Name	CCAC.1.12
ID	CCAC.1.12
On Site Location	CCAC.1.12
Type	Fixed Roof
Service	Crude Oil
Manufacturer	N/A
Model	N/A
Model Year	N/A
Installation Date	N/A
Roof Type	Flat Roof
Roof Colour	0
Shell Colour	0
Current Vent Control	0
Tank Height (m)	5
Tank Diameter (m)	4.7

General Analysis Data	
System Life (y)	10
Decline Rate ¹ (%/y)	15
Ambient Temperature (°C)	30
Ambient Pressure (kPa)	100.735
Flashing Technique ²	None
Working Technique ²	None
Tank Heater Set Point (°C)	30.0
Tank Temperature (°C)	32.0
Tank Pressure (kPa gage)	0.0
Separator Temperature (°C)	32.0
Separator Pressure (kPa gage)	186.7

²The calculation technique used to estimate the Flashing or Working Losses of the Tank.

Data Comments and Assumptions
CCAC.1.12

Device Comments and Assumptions
CCAC.1.12

Applied Emission Factors ³ (ng/l)		
Substance	Value	Source
CH ₄ Emission Factor		
N ₂ O Emission Factor		
VOC Emission Factor		
CO Emission Factor		
PM Emission Factor		
NO _x Emission Factor		
HC Destruction Efficiency (%)		

³ If current vent control system is tied to a flare.

Tank Stream Measurements

Property	Stream(s)		
	Separator Gas	Tank Vent	Tank Product
Temperature (°C)	32.0	32.0	32.0
Pressure (kPa gage)	186.7	0.0	0.0
Line Name	CCAC.1.12	CCAC.1.12	CCAC.1.12
Cross Sectional Shape	Circular	Circular	Circular
Pipe Outside Diameter (mm)	N/A	N/A	N/A
Pipe Wall Thickness (mm)	N/A	N/A	N/A
Pipe Rectangular Length (mm)	N/A	N/A	N/A
Pipe Rectangular Width (mm)	N/A	N/A	N/A
Measurement Type	Proration of Reported Unit Throughput	Process Simulation	Proration of Reported Unit Throughput
Reading Type	Flow Rate Standard Conditions	Flow Rate Standard Conditions	Flow Rate Standard Conditions
Measurement Date	N/A	N/A	N/A
Velocity (m/s)	---	---	---
Flow Rate (m ³ /h)	---	---	---
Standard Flow Rate (std m ³ /h)	2,045.3	1.3	1.0
Composition Name	CCAC.Comp.2	CCAC.Comp.2	CCAC.Comp.26
Composition ID	CCAC.Comp.2	CCAC.Comp.2	CCAC.Comp.26

ProductComposition Source Data

Analysis Administration Data	
Name	CCAC.Comp.26
Description and Comments	CCAC.Comp.26
Creation Date	2014-12-10
Sample Date	N/A
Sample Type	Computed (Gas/Molar)
Substance Type	Process Gas
Clearstone ID	CCAC.Comp.26

Analysis Results			
Component Name	Mole Fraction		
	Entered	Normalized	Air Free
Benzene	0.004427	0.004427	0.004427
Cyclohexane	0.008808	0.008808	0.008808
Dodecane	0.055442	0.055442	0.055442
Ethylbenzene	0.009565	0.009565	0.009565
Hexadecane	0.035986	0.035986	0.035986
Isobutane	0.000963	0.000963	0.000963
Isopentane	0.005237	0.005237	0.005237
Methylcyclohexane	0.009264	0.009264	0.009264
Methylcyclopentane	0.005975	0.005975	0.005975
n-Butane	0.005000	0.005000	0.005000
n-Decane	0.075602	0.075602	0.075602
n-Eicosane	0.276139	0.276139	0.276139
n-Heptadecane	0.031271	0.031271	0.031271
n-Heptane	0.037619	0.037619	0.037619
n-Hexane	0.029733	0.029733	0.029733
n-Nonadecane	0.027333	0.027333	0.027333
n-Nonane	0.052094	0.052094	0.052094
n-Octane	0.054558	0.054558	0.054558
n-Pentadecane	0.042085	0.042085	0.042085
n-Pentane	0.010327	0.010327	0.010327
n-Tetradecane	0.044131	0.044131	0.044131
n-Tridecane	0.051413	0.051413	0.051413
n-Undecane	0.063968	0.063968	0.063968
Octadecane	0.029765	0.029765	0.029765
o-Xylene	0.007875	0.007875	0.007875
Propane	0.005595	0.005595	0.005595
p-Xylene	0.007035	0.007035	0.007035
Toluene	0.012790	0.012790	0.012790
Total	1.000000	1.000000	1.000000

VentComposition Source Data

Analysis Administration Data	
Name	CCAC.Comp.2
Description and Comments	CCAC.Comp.2
Creation Date	2014-12-10
Sample Date	N/A
Sample Type	Computed (Gas/Molar)
Substance Type	Waste Gas
Clearstone ID	CCAC.Comp.2

Analysis Results			
Component Name	Mole Fraction		
	Entered	Normalized	Air Free
Carbon dioxide	0.061814	0.061814	0.061814
Ethane	0.052676	0.052676	0.052676
Hydrogen sulfide	0.001070	0.001070	0.001070
Isobutane	0.008419	0.008419	0.008419
Isopentane	0.002883	0.002883	0.002883
Methane	0.826408	0.826408	0.826408
n-Butane	0.011786	0.011786	0.011786
n-Hexane	0.000095	0.000095	0.000095
Nitrogen	0.002340	0.002340	0.002340
n-Pentane	0.000211	0.000211	0.000211
Propane	0.032296	0.032296	0.032296
Total	1.000000	1.000000	1.000000

Separator GasComposition Source Data

Analysis Administration Data	
Name	CCAC.Comp.2
Description and Comments	CCAC.Comp.2
Creation Date	2014-12-10
Sample Date	N/A
Sample Type	Computed (Gas/Molar)
Substance Type	Waste Gas
Clearstone ID	CCAC.Comp.2

Analysis Results			
Component Name	Mole Fraction		
	Entered	Normalized	Air Free
Carbon dioxide	0.061814	0.061814	0.061814
Ethane	0.052676	0.052676	0.052676
Hydrogen sulfide	0.001070	0.001070	0.001070
Isobutane	0.008419	0.008419	0.008419
Isopentane	0.002883	0.002883	0.002883
Methane	0.826408	0.826408	0.826408
n-Butane	0.011786	0.011786	0.011786
n-Hexane	0.000095	0.000095	0.000095
Nitrogen	0.002340	0.002340	0.002340
n-Pentane	0.000211	0.000211	0.000211
Propane	0.032296	0.032296	0.032296
Total	1.000000	1.000000	1.000000

Analysis Results

Source Name	Source Tag No.	Service Type
CCAC.1.12	CCAC.1.12	Crude Oil

Year Calculation Type	Value of Fuel/Loss Stream (USD/y)	Total Product Loss Flow (m ³ /h)	Total Product Losses				
			Residue Gas (10 ³ m ³ /d)	Ethane (m ³ /d liq)	LPG (m ³ /d liq)	C ₅ + (m ³ /d)	Hydrogen (m ³ /d)
Average	843	0.6	0.01	0.00	0.00	0.00	0.00
Year-0	1,736	1.3	0.02	0.01	0.01	0.00	0.00

Year Calculation Type	Total (Direct and Indirect) Emissions (t/y)								
	CH ₄	CO ₂	N ₂ O	CO ₂ E	VOC	CO	NO _x	SO ₂	PM
Average	3.0	1	0.00	63	0.6	0.0	0.0	0.0	0.0
Total	29.8	6	0.00	632	6.4	0.0	0.0	0.0	0.0
Year-0	6.1	1	0.00	130	1.3	0.0	0.0	0.0	0.0

No Control Technology Results



Tank Analysis Information

Facility	
Clearstone Client	CCAC.3
Data Client	CCAC.3
Operator	CCAC.3
Name	CCAC.3
Location	CCAC.3
ID	CCAC.3
Category	Battery
Type	Oil Multi-Well
Government ID	CCAC.3
Operator BA Code	CCAC.3
Licensee BA Code	CCAC.3
Licensee Name	CCAC.3

Data Administration Details	
Period Start	2014-09-29
Period End	2014-10-08
Data Contact	Chris Lusena
Prepared By	Chris Lusena
Report Generated	7-Dec-2015

General Analysis Data	
System Life (y)	10
Decline Rate ¹ (%/y)	15
Ambient Temperature (°C)	28
Ambient Pressure (kPa)	100.921
Flashing Technique ²	None
Working Technique ²	None
Tank Heater Set Point (°C)	30.0
Tank Temperature (°C)	30.0
Tank Pressure (kPa gage)	0.0
Seperator Temperature (°C)	30.0
Seperator Pressure (kPa gage)	186.6

Device	
Name	CCAC.3.10
ID	CCAC.3.10
On Site Location	CCAC.3.10
Type	Fixed Roof
Service	Crude Oil
Manufacturer	N/A
Model	N/A
Model Year	N/A
Installation Date	N/A
Roof Type	Flat Roof
Roof Colour	0
Shell Colour	0
Current Vent Control	0
Tank Height (m)	5
Tank Diameter (m)	11

²The calculation technique used to estimate the Flashing or Working Losses of the Tank.

Data Comments and Assumptions
CCAC.3.10

Device Comments and Assumptions
CCAC.3.10

Applied Emission Factors ³ (ng/l)		
Substance	Value	Source
CH ₄ Emission Factor		
N ₂ O Emission Factor		
VOC Emission Factor		
CO Emission Factor		
PM Emission Factor		
NO _x Emission Factor		
HC Destruction Efficiency (%)		

³ If current vent control system is tied to a flare.

Tank Stream Measurements

Property	Stream(s)		
	Separator Gas	Tank Vent	Tank Product
Temperature (°C)	30.0	30.0	30.0
Pressure (kPa gage)	186.6	0.0	0.0
Line Name	CCAC.3.10	CCAC.3.10	CCAC.3.10
Cross Sectional Shape	Circular	Circular	Circular
Pipe Outside Diameter (mm)	N/A	N/A	N/A
Pipe Wall Thickness (mm)	N/A	N/A	N/A
Pipe Rectangular Length (mm)	N/A	N/A	N/A
Pipe Rectangular Width (mm)	N/A	N/A	N/A
Measurement Type	Proration of Reported Unit Throughput	Process Simulation	Proration of Reported Unit Throughput
Reading Type	Flow Rate Standard Conditions	Flow Rate Standard Conditions	Flow Rate Standard Conditions
Measurement Date	N/A	N/A	N/A
Velocity (m/s)	---	---	---
Flow Rate (m ³ /h)	---	---	---
Standard Flow Rate (std m ³ /h)	818.0	3.6	1.3
Composition Name	CCAC.Comp.10	CCAC.Comp.10	CCAC.Comp.22
Composition ID	CCAC.Comp.10	CCAC.Comp.10	CCAC.Comp.22

ProductComposition Source Data

Analysis Administration Data	
Name	CCAC.Comp.22
Description and Comments	CCAC.Comp.22
Creation Date	2014-12-10
Sample Date	N/A
Sample Type	Computed (Gas/Molar)
Substance Type	Process Gas
Clearstone ID	CCAC.Comp.22

Analysis Results			
Component Name	Mole Fraction		
	Entered	Normalized	Air Free
Benzene	0.004427	0.004427	0.004427
Cyclohexane	0.008808	0.008808	0.008808
Dodecane	0.055442	0.055442	0.055442
Ethylbenzene	0.009565	0.009565	0.009565
Hexadecane	0.035986	0.035986	0.035986
Isobutane	0.000963	0.000963	0.000963
Isopentane	0.005237	0.005237	0.005237
Methylcyclohexane	0.009264	0.009264	0.009264
Methylcyclopentane	0.005975	0.005975	0.005975
n-Butane	0.005000	0.005000	0.005000
n-Decane	0.075602	0.075602	0.075602
n-Eicosane	0.276139	0.276139	0.276139
n-Heptadecane	0.031271	0.031271	0.031271
n-Heptane	0.037619	0.037619	0.037619
n-Hexane	0.029733	0.029733	0.029733
n-Nonadecane	0.027333	0.027333	0.027333
n-Nonane	0.052094	0.052094	0.052094
n-Octane	0.054558	0.054558	0.054558
n-Pentadecane	0.042085	0.042085	0.042085
n-Pentane	0.010327	0.010327	0.010327
n-Tetradecane	0.044131	0.044131	0.044131
n-Tridecane	0.051413	0.051413	0.051413
n-Undecane	0.063968	0.063968	0.063968
Octadecane	0.029765	0.029765	0.029765
o-Xylene	0.007875	0.007875	0.007875
Propane	0.005595	0.005595	0.005595
p-Xylene	0.007035	0.007035	0.007035
Toluene	0.012790	0.012790	0.012790
Total	1.000000	1.000000	1.000000

VentComposition Source Data

Analysis Administration Data	
Name	CCAC.Comp.10
Description and Comments	CCAC.Comp.10
Creation Date	2014-12-10
Sample Date	N/A
Sample Type	Computed (Gas/Molar)
Substance Type	Waste Gas
Clearstone ID	CCAC.Comp.10

Analysis Results			
Component Name	Mole Fraction		
	Entered	Normalized	Air Free
Carbon dioxide	0.231820	0.231815	0.231815
Ethane	0.132710	0.132707	0.132707
Isobutane	0.012190	0.012190	0.012190
Isopentane	0.003690	0.003690	0.003690
Methane	0.493650	0.493640	0.493640
n-Butane	0.026110	0.026109	0.026109
n-Hexane	0.000140	0.000140	0.000140
Nitrogen	0.001820	0.001820	0.001820
n-Pentane	0.002960	0.002960	0.002960
Propane	0.094930	0.094928	0.094928
Total	1.000020	1.000000	1.000000

Separator GasComposition Source Data

Analysis Administration Data	
Name	CCAC.Comp.10
Description and Comments	CCAC.Comp.10
Creation Date	2014-12-10
Sample Date	N/A
Sample Type	Computed (Gas/Molar)
Substance Type	Waste Gas
Clearstone ID	CCAC.Comp.10

Analysis Results			
Component Name	Mole Fraction		
	Entered	Normalized	Air Free
Carbon dioxide	0.231820	0.231815	0.231815
Ethane	0.132710	0.132707	0.132707
Isobutane	0.012190	0.012190	0.012190
Isopentane	0.003690	0.003690	0.003690
Methane	0.493650	0.493640	0.493640
n-Butane	0.026110	0.026109	0.026109
n-Hexane	0.000140	0.000140	0.000140
Nitrogen	0.001820	0.001820	0.001820
n-Pentane	0.002960	0.002960	0.002960
Propane	0.094930	0.094928	0.094928
Total	1.000020	1.000000	1.000000

Analysis Results

Source Name	Source Tag No.	Service Type
CCAC.3.10	CCAC.3.10	Crude Oil

Year Calculation Type	Value of Fuel/Loss Stream (USD/y)	Total Product Loss Flow (m ³ /h)	Total Product Losses				
			Residue Gas (10 ³ m ³ /d)	Ethane (m ³ /d liq)	LPG (m ³ /d liq)	C ₅ + (m ³ /d)	Hydrogen (m ³ /d)
Average	3,670	1.7	0.02	0.02	0.02	0.00	0.00
Year-0	7,559	3.6	0.04	0.04	0.04	0.00	0.00

Year Calculation Type	Total (Direct and Indirect) Emissions (t/y)								
	CH ₄	CO ₂	N ₂ O	CO ₂ E	VOC	CO	NO _x	SO ₂	PM
Average	5.1	7	0.00	114	4.5	0.0	0.0	0.0	0.0
Total	51.0	66	0.00	1,138	44.5	0.0	0.0	0.0	0.0
Year-0	10.5	14	0.00	234	9.2	0.0	0.0	0.0	0.0

Potential Control Options

Control Technology Type	Energy Recovery Efficiency (%)	Capital Cost (USD)	Net Present Salvage Value (USD)	Net Operating Cost (USD/y)	Value of Conserved Energy (USD/y)	NPV (10 ³ USD)	ROI (%)	Payback Period (y)
Vapour Recovery	100.00	19,200	0	4,688	7,559	-22	N/A	N/A

Control Technology Type	Year Calculation Type	Estimated Emission Reduction Potential (t/y)								
		CH ₄	CO ₂	N ₂ O	CO ₂ E	VOC	CO	NO _x	SO ₂	PM
Vapour Recovery	Average	5.10	-19	-0.00	88	4.45	-0.06	-0.01	0.00	-0.02
	Total	50.99	-192	-0.00	879	44.45	-0.64	-0.12	0.00	-0.23
	Year-0	10.50	-39	-0.00	181	9.16	-0.13	-0.02	0.00	-0.05

Control Technology Input

Device and Facility	
Clearstone Client	CCAC.3.10
Data Client	CCAC.3.10
Device Facility	CCAC.3
Device Name	CCAC.3.10
Device ID	CCAC.3.10

Economic Assumptions	
System Life (y)	10.0
Application Life (y)	10.0
Electrical Usage Rating (kWh/y)	0
Replacement Salvage Value (USD)	0
Technology EOL Salvage Value (USD)	0
Operating Cost (USD/y)	0
Operating Cost Factor	1.000
Operating Costs Avoided (USD/y)	0

Control Technology Comments
CCAC.3.10

Control Technology	
Type	Vapour Recovery
Combustion Type	Flare Stack (Unassisted)
Stream Reduction Factor (%)	100.00
Hydrocarbon Reduction Factor (%)	0.00
Sulphur Reduction Factor (%)	0.00
Application Description	Pesimistic cost

Applied Emission Factors ¹		
Substance	Value	Source
CH ₄ Emission Factor (ng/J)	33.10	US EPA AP-42
N ₂ O Emission Factor (ng/J)	0.10	US EPA AP-42
VOC Emission Factor (ng/J)	11.97	User Entered
CO Emission Factor (ng/J)	159.10	US EPA AP-42
PM Emission Factor (ng/J)	57.00	US EPA AP-42
NO _x Emission Factor (ng/J)	29.20	US EPA AP-42
HC Destruction Efficiency (%)	99.83	User Entered

¹ Emission Factors used in simulation if the Control Technology consumes fuel as part of its operation.

Control Technology Stream Measurements

Property	Stream(s)	
	Fuel	Recovery
Temperature (°C)	15	15
Pressure (kPa gage)	0	0
Line Name	CCAC.3.10	CCAC.3.10
Cross Sectional Shape	Circular	Circular
Pipe Outside Diameter (mm)	N/A	N/A
Pipe Wall Thickness (mm)	N/A	N/A
Pipe Rectangular Length (mm)	N/A	N/A
Pipe Rectangular Width (mm)	N/A	N/A
Measurement Type	Process Simulation	Process Simulation
Reading Type	Molar Flow Rate	Molar Flow Rate
Measurement Date	N/A	N/A
Velocity (m/s)	---	---
Flow Rate (m ³ /h)	---	---
Standard Flow Rate (std m ³ /h)	3.10669	0.476642
Composition Name	CCAC.Comp.10	CCAC.Comp.8
Composition ID	CCAC.Comp.10	CCAC.Comp.8

Composition Source Data

Analysis Administration Data	
Name	CCAC.Comp.10
Description and Comments	CCAC.Comp.10
Creation Date	2014-12-10
Sample Date	N/A
Sample Type	Computed (Gas/Molar)
Substance Type	Waste Gas
Clearstone ID	CCAC.Comp.10

Analysis Results			
Component Name	Mole Fraction		
	Entered	Normalized	Air Free
Carbon dioxide	0.231820	0.231815	0.231815
Ethane	0.132710	0.132707	0.132707
Isobutane	0.012190	0.012190	0.012190
Isopentane	0.003690	0.003690	0.003690
Methane	0.493650	0.493640	0.493640
n-Butane	0.026110	0.026109	0.026109
n-Hexane	0.000140	0.000140	0.000140
Nitrogen	0.001820	0.001820	0.001820
n-Pentane	0.002960	0.002960	0.002960
Propane	0.094930	0.094928	0.094928
Total	1.000020	1.000000	1.000000

Composition Source Data

Analysis Administration Data	
Name	CCAC.Comp.8
Description and Comments	CCAC.Comp.8
Creation Date	2015-11-30
Sample Date	N/A
Sample Type	Computed (Gas/Molar)
Substance Type	Unknown
Clearstone ID	CCAC.Comp.8

Analysis Results			
Component Name	Mole Fraction		
	Entered	Normalized	Air Free
Carbon dioxide	0.048202	0.048202	0.048202
Ethane	0.099997	0.099997	0.099997
Isobutane	0.103537	0.103537	0.103537
Isopentane	0.051608	0.051608	0.051608
Methane	0.015015	0.015015	0.015015
n-Butane	0.257026	0.257026	0.257026
n-Hexane	0.002519	0.002519	0.002519
Nitrogen	0.000007	0.000007	0.000007
n-Pentane	0.042687	0.042687	0.042687
Propane	0.379402	0.379402	0.379402
Total	1.000000	1.000000	1.000000

Production Decline Economics

Application Life (years)	Monetary Discount Rate (%/year)	Applied Production Decline Rate (%/year)	Assumed Inflation Rate (%/year)
10.0	10.0	15.0	0.0

Year	Revenues ¹ (USD)	Costs ¹ (USD)	Net Revenues (USD)	Net Present Value ² (USD)	ROI ³ (%)
0	0	19,200	-19,200	-19,200	—
1	6,601	4,688	1,912	1,738	10.0
1	6,601	4,688	1,912	1,738	10.0
1	6,601	4,688	1,912	1,738	10.0
1	6,601	4,688	1,912	1,738	10.0
2	5,764	4,688	1,076	889	5.6
2	5,764	4,688	1,076	889	5.6
2	5,764	4,688	1,076	889	5.6
2	5,764	4,688	1,076	889	5.6
3	5,034	4,688	345	259	1.8
3	5,034	4,688	345	259	1.8
3	5,034	4,688	345	259	1.8
3	5,034	4,688	345	259	1.8
4	4,396	4,688	-293	-200	-1.5
4	4,396	4,688	-293	-200	-1.5
4	4,396	4,688	-293	-200	-1.5
4	4,396	4,688	-293	-200	-1.5
5	3,838	4,688	-850	-528	-4.4
5	3,838	4,688	-850	-528	-4.4
5	3,838	4,688	-850	-528	-4.4
5	3,838	4,688	-850	-528	-4.4
6	3,352	4,688	-1,336	-754	-7.0
6	3,352	4,688	-1,336	-754	-7.0
6	3,352	4,688	-1,336	-754	-7.0
6	3,352	4,688	-1,336	-754	-7.0
7	2,927	4,688	-1,761	-904	-9.2
7	2,927	4,688	-1,761	-904	-9.2
7	2,927	4,688	-1,761	-904	-9.2
7	2,927	4,688	-1,761	-904	-9.2
8	2,556	4,688	-2,132	-995	-11.1
8	2,556	4,688	-2,132	-995	-11.1
8	2,556	4,688	-2,132	-995	-11.1
8	2,556	4,688	-2,132	-995	-11.1

9	2,232	4,688	-2,456	-1,042	-12.8
9	2,232	4,688	-2,456	-1,042	-12.8
9	2,232	4,688	-2,456	-1,042	-12.8
9	2,232	4,688	-2,456	-1,042	-12.8
10	1,949	4,688	-2,739	-1,056	-14.3
10	1,949	4,688	-2,739	-1,056	-14.3
10	1,949	4,688	-2,739	-1,056	-14.3
10	1,949	4,688	-2,739	-1,056	-14.3
Total	154,597	206,734	-52,137	-29,565	-4.3

¹ For year 0 Costs and Revenues represent capital cost and salvage values. For other years they represent operating cost and revenues in current year dollars.

² Net Present Value is expressed in Year-0 dollars.

³ ROI is current year net revenues over capital cost in Year-0 dollars. The Total row for this column is the median ROI value over the operating years.

Capital Cost Details

Control Technology Type	Application description
Vapour Recovery	Pesimistic cost

Cost Category	Cost Item Type	Item Description	Rate (USD/Unit)	Quantity (Unit)	Line Total (USD)
Lump sum	Lump sum	Cost (\$/m3/h)	4,800.00	4.0	19,200

Total 19,200



Tank Analysis Information

Facility	
Clearstone Client	CCAC.4
Data Client	CCAC.4
Operator	CCAC.4
Name	CCAC.4
Location	CCAC.4
ID	CCAC.4
Category	Battery
Type	Oil Multi-Well
Government ID	CCAC.4
Operator BA Code	CCAC.4
Licensee BA Code	CCAC.4
Licensee Name	CCAC.4

Data Administration Details	
Period Start	2014-09-29
Period End	2014-10-08
Data Contact	Chris Lusena
Prepared By	Chris Lusena
Report Generated	7-Dec-2015

Device	
Name	CCAC.4.14
ID	CCAC.4.14
On Site Location	CCAC.4.14
Type	Fixed Roof
Service	Crude Oil
Manufacturer	N/A
Model	N/A
Model Year	N/A
Installation Date	N/A
Roof Type	Flat Roof
Roof Colour	0
Shell Colour	0
Current Vent Control	1
Tank Height (m)	5
Tank Diameter (m)	10

General Analysis Data	
System Life (y)	10
Decline Rate ¹ (%/y)	15
Ambient Temperature (°C)	30
Ambient Pressure (kPa)	100.735
Flashing Technique ²	None
Working Technique ²	None
Tank Heater Set Point (°C)	50.0
Tank Temperature (°C)	37.6
Tank Pressure (kPa gage)	0.0
Separator Temperature (°C)	37.6
Separator Pressure (kPa gage)	187.0

²The calculation technique used to estimate the Flashing or Working Losses of the Tank.

Data Comments and Assumptions
CCAC.4.14

Device Comments and Assumptions
CCAC.4.14

Applied Emission Factors ³ (ng/l)		
Substance	Value	Source
CH ₄ Emission Factor		
N ₂ O Emission Factor		
VOC Emission Factor		
CO Emission Factor		
PM Emission Factor		
NO _x Emission Factor		
HC Destruction Efficiency (%)		

³ If current vent control system is tied to a flare.

Tank Stream Measurements

Property	Stream(s)		
	Separator Gas	Tank Vent	Tank Product
Temperature (°C)	37.6	37.6	37.6
Pressure (kPa gage)	187.0	0.0	0.0
Line Name	CCAC.4.14	CCAC.4.14	CCAC.4.14
Cross Sectional Shape	Circular	Circular	Circular
Pipe Outside Diameter (mm)	N/A	N/A	N/A
Pipe Wall Thickness (mm)	N/A	N/A	N/A
Pipe Rectangular Length (mm)	N/A	N/A	N/A
Pipe Rectangular Width (mm)	N/A	N/A	N/A
Measurement Type	Proration of Reported Unit Throughput	Process Simulation	Proration of Reported Unit Throughput
Reading Type	Flow Rate Standard Conditions	Flow Rate Standard Conditions	Flow Rate Standard Conditions
Measurement Date	N/A	N/A	N/A
Velocity (m/s)	---	---	---
Flow Rate (m ³ /h)	---	---	---
Standard Flow Rate (std m ³ /h)	258.5	0.0	3.1
Composition Name	CCAC.Comp.12	CCAC.Comp.12	CCAC.Comp.28
Composition ID	CCAC.Comp.12	CCAC.Comp.12	CCAC.Comp.28

ProductComposition Source Data

Analysis Administration Data	
Name	CCAC.Comp.28
Description and Comments	CCAC.Comp.28
Creation Date	2014-12-10
Sample Date	N/A
Sample Type	Computed (Gas/Molar)
Substance Type	Process Gas
Clearstone ID	CCAC.Comp.28

Analysis Results			
Component Name	Mole Fraction		
	Entered	Normalized	Air Free
Benzene	0.004427	0.004427	0.004427
Cyclohexane	0.008808	0.008808	0.008808
Dodecane	0.055442	0.055442	0.055442
Ethylbenzene	0.009565	0.009565	0.009565
Hexadecane	0.035986	0.035986	0.035986
Isobutane	0.000963	0.000963	0.000963
Isopentane	0.005237	0.005237	0.005237
Methylcyclohexane	0.009264	0.009264	0.009264
Methylcyclopentane	0.005975	0.005975	0.005975
n-Butane	0.005000	0.005000	0.005000
n-Decane	0.075602	0.075602	0.075602
n-Eicosane	0.276139	0.276139	0.276139
n-Heptadecane	0.031271	0.031271	0.031271
n-Heptane	0.037619	0.037619	0.037619
n-Hexane	0.029733	0.029733	0.029733
n-Nonadecane	0.027333	0.027333	0.027333
n-Nonane	0.052094	0.052094	0.052094
n-Octane	0.054558	0.054558	0.054558
n-Pentadecane	0.042085	0.042085	0.042085
n-Pentane	0.010327	0.010327	0.010327
n-Tetradecane	0.044131	0.044131	0.044131
n-Tridecane	0.051413	0.051413	0.051413
n-Undecane	0.063968	0.063968	0.063968
Octadecane	0.029765	0.029765	0.029765
o-Xylene	0.007875	0.007875	0.007875
Propane	0.005595	0.005595	0.005595
p-Xylene	0.007035	0.007035	0.007035
Toluene	0.012790	0.012790	0.012790
Total	1.000000	1.000000	1.000000

VentComposition Source Data

Analysis Administration Data	
Name	CCAC.Comp.12
Description and Comments	CCAC.Comp.12
Creation Date	2014-12-04
Sample Date	2013-03-20
Sample Type	As Sampled (Gas/Molar)
Substance Type	Process Gas
Clearstone ID	CCAC.Comp.12

Analysis Results			
Component Name	Mole Fraction		
	Entered	Normalized	Air Free
Carbon dioxide	0.212420	0.212420	0.212420
Ethane	0.093276	0.093276	0.093276
Hydrogen sulfide	0.003568	0.003568	0.003568
Isobutane	0.008429	0.008429	0.008429
Isopentane	0.004485	0.004485	0.004485
Methane	0.564001	0.564001	0.564001
n-Butane	0.026089	0.026089	0.026089
n-Hexane	0.000281	0.000281	0.000281
Nitrogen	0.011426	0.011426	0.011426
n-Pentane	0.004571	0.004571	0.004571
Propane	0.071454	0.071454	0.071454
Total	1.000000	1.000000	1.000000

Separator GasComposition Source Data

Analysis Administration Data	
Name	CCAC.Comp.12
Description and Comments	CCAC.Comp.12
Creation Date	2014-12-04
Sample Date	2013-03-20
Sample Type	As Sampled (Gas/Molar)
Substance Type	Process Gas
Clearstone ID	CCAC.Comp.12

Analysis Results			
Component Name	Mole Fraction		
	Entered	Normalized	Air Free
Carbon dioxide	0.212420	0.212420	0.212420
Ethane	0.093276	0.093276	0.093276
Hydrogen sulfide	0.003568	0.003568	0.003568
Isobutane	0.008429	0.008429	0.008429
Isopentane	0.004485	0.004485	0.004485
Methane	0.564001	0.564001	0.564001
n-Butane	0.026089	0.026089	0.026089
n-Hexane	0.000281	0.000281	0.000281
Nitrogen	0.011426	0.011426	0.011426
n-Pentane	0.004571	0.004571	0.004571
Propane	0.071454	0.071454	0.071454
Total	1.000000	1.000000	1.000000

Analysis Results

Source Name	Source Tag No.	Service Type
CCAC.4.14	CCAC.4.14	Crude Oil

Year Calculation Type	Value of Fuel/Loss Stream (USD/y)	Total Product Loss Flow (m ³ /h)	Total Product Losses				
			Residue Gas (10 ³ m ³ /d)	Ethane (m ³ /d liq)	LPG (m ³ /d liq)	C ₅ + (m ³ /d)	Hydrogen (m ³ /d)
Average	0	0.0	0.00	0.00	0.00	0.00	0.00
Year-0	0	0.0	0.00	0.00	0.00	0.00	0.00

Year Calculation Type	Total (Direct and Indirect) Emissions (t/y)								
	CH ₄	CO ₂	N ₂ O	CO ₂ E	VOC	CO	NO _x	SO ₂	PM
Average	0.0	0	0.00	0	0.0	0.0	0.0	0.0	0.0
Total	0.0	0	0.00	0	0.0	0.0	0.0	0.0	0.0
Year-0	0.0	0	0.00	0	0.0	0.0	0.0	0.0	0.0

No Control Technology Results



Tank Analysis Information

Facility	
Clearstone Client	CCAC.5
Data Client	CCAC.5
Operator	CCAC.5
Name	CCAC.5
Location	CCAC.5
ID	CCAC.5
Category	Battery
Type	Oil Multi-Well
Government ID	CCAC.5
Operator BA Code	CCAC.5
Licensee BA Code	CCAC.5
Licensee Name	CCAC.5

Data Administration Details	
Period Start	2014-09-29
Period End	2014-10-08
Data Contact	Chris Lusena
Prepared By	Chris Lusena
Report Generated	7-Dec-2015

General Analysis Data	
System Life (y)	10
Decline Rate ¹ (%/y)	15
Ambient Temperature (°C)	29
Ambient Pressure (kPa)	100.477
Flashing Technique ²	None
Working Technique ²	None
Tank Heater Set Point (°C)	50.0
Tank Temperature (°C)	35.1
Tank Pressure (kPa gage)	0.0
Seperator Temperature (°C)	35.1
Seperator Pressure (kPa gage)	152.5

Device	
Name	CCAC.5.13
ID	CCAC.5.13
On Site Location	CCAC.5.13
Type	Fixed Roof
Service	Crude Oil
Manufacturer	N/A
Model	N/A
Model Year	N/A
Installation Date	N/A
Roof Type	Flat Roof
Roof Colour	0
Shell Colour	0
Current Vent Control	0
Tank Hieght (m)	5
Tank Diameter (m)	3.5

²The calculation technique used to estimate the Flashing or Working Losses of the Tank.

Data Comments and Assumptions
CCAC.5.13

Device Comments and Assumptions
CCAC.5.13

Applied Emission Factors ³ (ng/l)		
Substance	Value	Source
CH ₄ Emission Factor		
N ₂ O Emission Factor		
VOC Emission Factor		
CO Emission Factor		
PM Emission Factor		
NO _x Emission Factor		
HC Destruction Efficiency (%)		

³ If current vent control system is tied to a flare.

Tank Stream Measurements

Property	Stream(s)		
	Separator Gas	Tank Vent	Tank Product
Temperature (°C)	35.1	35.1	35.1
Pressure (kPa gage)	152.5	0.0	0.0
Line Name	CCAC.5.13	CCAC.5.13	CCAC.5.13
Cross Sectional Shape	Circular	Circular	Circular
Pipe Outside Diameter (mm)	N/A	N/A	N/A
Pipe Wall Thickness (mm)	N/A	N/A	N/A
Pipe Rectangular Length (mm)	N/A	N/A	N/A
Pipe Rectangular Width (mm)	N/A	N/A	N/A
Measurement Type	Proration of Reported Unit Throughput	Process Simulation	Proration of Reported Unit Throughput
Reading Type	Flow Rate Standard Conditions	Flow Rate Standard Conditions	Flow Rate Standard Conditions
Measurement Date	N/A	N/A	N/A
Velocity (m/s)	---	---	---
Flow Rate (m ³ /h)	---	---	---
Standard Flow Rate (std m ³ /h)	1,032.7	4.4	3.6
Composition Name	CCAC.Comp.15	CCAC.Comp.15	CCAC.Comp.27
Composition ID	CCAC.Comp.15	CCAC.Comp.15	CCAC.Comp.27

ProductComposition Source Data

Analysis Administration Data	
Name	CCAC.Comp.27
Description and Comments	CCAC.Comp.27
Creation Date	2014-12-10
Sample Date	N/A
Sample Type	Computed (Gas/Molar)
Substance Type	Sales Gas
Clearstone ID	CCAC.Comp.27

Analysis Results			
Component Name	Mole Fraction		
	Entered	Normalized	Air Free
Benzene	0.004427	0.004427	0.004427
Cyclohexane	0.008808	0.008808	0.008808
Dodecane	0.055442	0.055442	0.055442
Ethylbenzene	0.009565	0.009565	0.009565
Hexadecane	0.035986	0.035986	0.035986
Isobutane	0.000963	0.000963	0.000963
Isopentane	0.005237	0.005237	0.005237
Methylcyclohexane	0.009264	0.009264	0.009264
Methylcyclopentane	0.005975	0.005975	0.005975
n-Butane	0.005000	0.005000	0.005000
n-Decane	0.075602	0.075602	0.075602
n-Eicosane	0.276139	0.276139	0.276139
n-Heptadecane	0.031271	0.031271	0.031271
n-Heptane	0.037619	0.037619	0.037619
n-Hexane	0.029733	0.029733	0.029733
n-Nonadecane	0.027333	0.027333	0.027333
n-Nonane	0.052094	0.052094	0.052094
n-Octane	0.054558	0.054558	0.054558
n-Pentadecane	0.042085	0.042085	0.042085
n-Pentane	0.010327	0.010327	0.010327
n-Tetradecane	0.044131	0.044131	0.044131
n-Tridecane	0.051413	0.051413	0.051413
n-Undecane	0.063968	0.063968	0.063968
Octadecane	0.029765	0.029765	0.029765
o-Xylene	0.007875	0.007875	0.007875
Propane	0.005595	0.005595	0.005595
p-Xylene	0.007035	0.007035	0.007035
Toluene	0.012790	0.012790	0.012790
Total	1.000000	1.000000	1.000000

VentComposition Source Data

Analysis Administration Data	
Name	CCAC.Comp.15
Description and Comments	CCAC.Comp.15
Creation Date	2014-12-10
Sample Date	N/A
Sample Type	Computed (Gas/Molar)
Substance Type	Waste Gas
Clearstone ID	CCAC.Comp.15

Analysis Results			
Component Name	Mole Fraction		
	Entered	Normalized	Air Free
Carbon dioxide	0.089598	0.089598	0.089598
Ethane	0.086336	0.086336	0.086336
Isobutane	0.007467	0.007467	0.007467
Isopentane	0.006549	0.006549	0.006549
Methane	0.695377	0.695377	0.695377
n-Butane	0.020575	0.020575	0.020575
n-Hexane	0.005174	0.005174	0.005174
Nitrogen	0.045100	0.045100	0.045100
n-Pentane	0.006828	0.006828	0.006828
Propane	0.036996	0.036996	0.036996
Total	1.000000	1.000000	1.000000

Separator GasComposition Source Data

Analysis Administration Data	
Name	CCAC.Comp.15
Description and Comments	CCAC.Comp.15
Creation Date	2014-12-10
Sample Date	N/A
Sample Type	Computed (Gas/Molar)
Substance Type	Waste Gas
Clearstone ID	CCAC.Comp.15

Analysis Results			
Component Name	Mole Fraction		
	Entered	Normalized	Air Free
Carbon dioxide	0.089598	0.089598	0.089598
Ethane	0.086336	0.086336	0.086336
Isobutane	0.007467	0.007467	0.007467
Isopentane	0.006549	0.006549	0.006549
Methane	0.695377	0.695377	0.695377
n-Butane	0.020575	0.020575	0.020575
n-Hexane	0.005174	0.005174	0.005174
Nitrogen	0.045100	0.045100	0.045100
n-Pentane	0.006828	0.006828	0.006828
Propane	0.036996	0.036996	0.036996
Total	1.000000	1.000000	1.000000

Analysis Results

Source Name	Source Tag No.	Service Type
CCAC.5.13	CCAC.5.13	Crude Oil

Year Calculation Type	Value of Fuel/Loss Stream (USD/y)	Total Product Loss Flow (m ³ /h)	Total Product Losses				
			Residue Gas (10 ³ m ³ /d)	Ethane (m ³ /d liq)	LPG (m ³ /d liq)	C ₅ + (m ³ /d)	Hydrogen (m ³ /d)
Average	3,656	2.1	0.04	0.02	0.01	0.00	0.00
Year-0	7,530	4.4	0.07	0.03	0.03	0.01	0.00

Year Calculation Type	Total (Direct and Indirect) Emissions (t/y)								
	CH ₄	CO ₂	N ₂ O	CO ₂ E	VOC	CO	NO _x	SO ₂	PM
Average	8.9	3	0.00	189	3.7	0.0	0.0	0.0	0.0
Total	88.6	31	0.00	1,893	37.1	0.0	0.0	0.0	0.0
Year-0	18.3	6	0.00	390	7.6	0.0	0.0	0.0	0.0

No Control Technology Results



Tank Analysis Information

Facility	
Clearstone Client	CCAC.6
Data Client	CCAC.6
Operator	CCAC.6
Name	CCAC.6
Location	CCAC.6
ID	CCAC.6
Category	Battery
Type	Oil Multi-Well
Government ID	CCAC.6
Operator BA Code	CCAC.6
Licensee BA Code	CCAC.6
Licensee Name	CCAC.6

Data Administration Details	
Period Start	2014-09-29
Period End	2014-10-08
Data Contact	Chris Lusena
Prepared By	Chris Lusena
Report Generated	7-Dec-2015

Device	
Name	CCAC.6.11
ID	CCAC.6.11
On Site Location	CCAC.6.11
Type	Fixed Roof
Service	Crude Oil
Manufacturer	N/A
Model	N/A
Model Year	N/A
Installation Date	N/A
Roof Type	Flat Roof
Roof Colour	0
Shell Colour	0
Current Vent Control	0
Tank Height (m)	5
Tank Diameter (m)	8

General Analysis Data	
System Life (y)	10
Decline Rate ¹ (%/y)	15
Ambient Temperature (°C)	28
Ambient Pressure (kPa)	100.921
Flashing Technique ²	None
Working Technique ²	None
Tank Heater Set Point (°C)	30.0
Tank Temperature (°C)	36.7
Tank Pressure (kPa gage)	0.0
Separator Temperature (°C)	36.7
Separator Pressure (kPa gage)	131.4

²The calculation technique used to estimate the Flashing or Working Losses of the Tank.

Data Comments and Assumptions
CCAC.6.11

Device Comments and Assumptions
CCAC.6.11

Applied Emission Factors ³ (ng/l)		
Substance	Value	Source
CH ₄ Emission Factor		
N ₂ O Emission Factor		
VOC Emission Factor		
CO Emission Factor		
PM Emission Factor		
NO _x Emission Factor		
HC Destruction Efficiency (%)		

³ If current vent control system is tied to a flare.

Tank Stream Measurements

Property	Stream(s)		
	Separator Gas	Tank Vent	Tank Product
Temperature (°C)	36.7	36.7	36.7
Pressure (kPa gage)	131.4	0.0	0.0
Line Name	CCAC.6.11	CCAC.6.11	CCAC.6.11
Cross Sectional Shape	Circular	Circular	Circular
Pipe Outside Diameter (mm)	N/A	N/A	N/A
Pipe Wall Thickness (mm)	N/A	N/A	N/A
Pipe Rectangular Length (mm)	N/A	N/A	N/A
Pipe Rectangular Width (mm)	N/A	N/A	N/A
Measurement Type	Proration of Reported Unit Throughput	Process Simulation	Proration of Reported Unit Throughput
Reading Type	Flow Rate Standard Conditions	Flow Rate Standard Conditions	Flow Rate Standard Conditions
Measurement Date	N/A	N/A	N/A
Velocity (m/s)	---	---	---
Flow Rate (m ³ /h)	---	---	---
Standard Flow Rate (std m ³ /h)	331.1	0.7	0.4
Composition Name	CCAC.Comp.19	CCAC.Comp.19	CCAC.Comp.25
Composition ID	CCAC.Comp.19	CCAC.Comp.19	CCAC.Comp.25

ProductComposition Source Data

Analysis Administration Data	
Name	CCAC.Comp.25
Description and Comments	CCAC.Comp.25
Creation Date	2014-12-10
Sample Date	N/A
Sample Type	Computed (Gas/Molar)
Substance Type	Tank Vapour
Clearstone ID	CCAC.Comp.25

Analysis Results			
Component Name	Mole Fraction		
	Entered	Normalized	Air Free
Benzene	0.004427	0.004427	0.004427
Cyclohexane	0.008808	0.008808	0.008808
Dodecane	0.055442	0.055442	0.055442
Ethylbenzene	0.009565	0.009565	0.009565
Hexadecane	0.035986	0.035986	0.035986
Isobutane	0.000963	0.000963	0.000963
Isopentane	0.005237	0.005237	0.005237
Methylcyclohexane	0.009264	0.009264	0.009264
Methylcyclopentane	0.005975	0.005975	0.005975
n-Butane	0.005000	0.005000	0.005000
n-Decane	0.075602	0.075602	0.075602
n-Eicosane	0.276139	0.276139	0.276139
n-Heptadecane	0.031271	0.031271	0.031271
n-Heptane	0.037619	0.037619	0.037619
n-Hexane	0.029733	0.029733	0.029733
n-Nonadecane	0.027333	0.027333	0.027333
n-Nonane	0.052094	0.052094	0.052094
n-Octane	0.054558	0.054558	0.054558
n-Pentadecane	0.042085	0.042085	0.042085
n-Pentane	0.010327	0.010327	0.010327
n-Tetradecane	0.044131	0.044131	0.044131
n-Tridecane	0.051413	0.051413	0.051413
n-Undecane	0.063968	0.063968	0.063968
Octadecane	0.029765	0.029765	0.029765
o-Xylene	0.007875	0.007875	0.007875
Propane	0.005595	0.005595	0.005595
p-Xylene	0.007035	0.007035	0.007035
Toluene	0.012790	0.012790	0.012790
Total	1.000000	1.000000	1.000000

VentComposition Source Data

Analysis Administration Data	
Name	CCAC.Comp.19
Description and Comments	CCAC.Comp.19
Creation Date	2014-12-10
Sample Date	N/A
Sample Type	Computed (Gas/Molar)
Substance Type	Waste Gas
Clearstone ID	CCAC.Comp.19

Analysis Results			
Component Name	Mole Fraction		
	Entered	Normalized	Air Free
Carbon dioxide	0.255839	0.255839	0.255839
Ethane	0.118923	0.118923	0.118923
Isobutane	0.015330	0.015330	0.015330
Isopentane	0.009896	0.009896	0.009896
Methane	0.392249	0.392249	0.392249
n-Butane	0.038813	0.038813	0.038813
n-Hexane	0.005209	0.005209	0.005209
Nitrogen	0.048181	0.048181	0.048181
n-Pentane	0.010390	0.010390	0.010390
Propane	0.105169	0.105169	0.105169
Total	1.000000	1.000000	1.000000

Separator GasComposition Source Data

Analysis Administration Data	
Name	CCAC.Comp.19
Description and Comments	CCAC.Comp.19
Creation Date	2014-12-10
Sample Date	N/A
Sample Type	Computed (Gas/Molar)
Substance Type	Waste Gas
Clearstone ID	CCAC.Comp.19

Analysis Results			
Component Name	Mole Fraction		
	Entered	Normalized	Air Free
Carbon dioxide	0.255839	0.255839	0.255839
Ethane	0.118923	0.118923	0.118923
Isobutane	0.015330	0.015330	0.015330
Isopentane	0.009896	0.009896	0.009896
Methane	0.392249	0.392249	0.392249
n-Butane	0.038813	0.038813	0.038813
n-Hexane	0.005209	0.005209	0.005209
Nitrogen	0.048181	0.048181	0.048181
n-Pentane	0.010390	0.010390	0.010390
Propane	0.105169	0.105169	0.105169
Total	1.000000	1.000000	1.000000

Analysis Results

Source Name	Source Tag No.	Service Type
CCAC.6.11	CCAC.6.11	Crude Oil

Year Calculation Type	Value of Fuel/Loss Stream (USD/y)	Total Product Loss Flow (m ³ /h)	Total Product Losses				
			Residue Gas (10 ³ m ³ /d)	Ethane (m ³ /d liq)	LPG (m ³ /d liq)	C ₅ + (m ³ /d)	Hydrogen (m ³ /d)
Average	833	0.3	0.00	0.00	0.00	0.00	0.00
Year-0	1,716	0.7	0.01	0.01	0.01	0.00	0.00

Year Calculation Type	Total (Direct and Indirect) Emissions (t/y)								
	CH ₄	CO ₂	N ₂ O	CO ₂ E	VOC	CO	NO _x	SO ₂	PM
Average	0.8	1	0.00	17	1.2	0.0	0.0	0.0	0.0
Total	7.5	14	0.00	172	11.6	0.0	0.0	0.0	0.0
Year-0	1.6	3	0.00	35	2.4	0.0	0.0	0.0	0.0

Potential Control Options

Control Technology Type	Energy Recovery Efficiency (%)	Capital Cost (USD)	Net Present Salvage Value (USD)	Net Operating Cost (USD/y)	Value of Conserved Energy (USD/y)	NPV (10 ³ USD)	ROI (%)	Payback Period (y)
Vapour Recovery	100.00	14,400	0	416	1,716	-11	3.20	N/A

Control Technology Type	Year Calculation Type	Estimated Emission Reduction Potential (t/y)								
		CH ₄	CO ₂	N ₂ O	CO ₂ E	VOC	CO	NO _x	SO ₂	PM
Vapour Recovery	Average	0.70	-4	-0.00	11	1.11	-0.01	-0.00	0.00	-0.00
	Total	6.96	-35	-0.00	111	11.14	-0.11	-0.02	0.00	-0.04
	Year-0	1.43	-7	-0.00	23	2.29	-0.02	-0.00	0.00	-0.01

Control Technology Input

Device and Facility	
Clearstone Client	CCAC.6.11
Data Client	CCAC.6.11
Device Facility	CCAC.6
Device Name	CCAC.6.11
Device ID	CCAC.6.11

Economic Assumptions	
System Life (y)	10.0
Application Life (y)	10.0
Electrical Usage Rating (kWh/y)	0
Replacement Salvage Value (USD)	0
Technology EOL Salvage Value (USD)	0
Operating Cost (USD/y)	0
Operating Cost Factor	1.000
Operating Costs Avoided (USD/y)	0

Control Technology Comments
CCAC.6.11

Control Technology	
Type	Vapour Recovery
Combustion Type	Flare Stack (Unassisted)
Stream Reduction Factor (%)	100.00
Hydrocarbon Reduction Factor (%)	0.00
Sulphur Reduction Factor (%)	0.00
Application Description	Pesimistic cost

Applied Emission Factors ¹		
Substance	Value	Source
CH ₄ Emission Factor (ng/J)	33.10	US EPA AP-42
N ₂ O Emission Factor (ng/J)	0.10	US EPA AP-42
VOC Emission Factor (ng/J)	730.72	User Entered
CO Emission Factor (ng/J)	159.10	US EPA AP-42
PM Emission Factor (ng/J)	57.00	US EPA AP-42
NO _x Emission Factor (ng/J)	29.20	US EPA AP-42
HC Destruction Efficiency (%)	92.28	User Entered

¹ Emission Factors used in simulation if the Control Technology consumes fuel as part of its operation.

Control Technology Stream Measurements

Property	Stream(s)	
	Fuel	Recovery
Temperature (°C)	15	15
Pressure (kPa gage)	0	0
Line Name	CCAC.6.11	CCAC.6.11
Cross Sectional Shape	Circular	Circular
Pipe Outside Diameter (mm)	N/A	N/A
Pipe Wall Thickness (mm)	N/A	N/A
Pipe Rectangular Length (mm)	N/A	N/A
Pipe Rectangular Width (mm)	N/A	N/A
Measurement Type	Process Simulation	Process Simulation
Reading Type	Flow Rate Standard Conditions	Flow Rate Standard Conditions
Measurement Date	N/A	N/A
Velocity (m/s)	---	---
Flow Rate (m ³ /h)	---	---
Standard Flow Rate (std m ³ /h)	0.549622	0.117045
Composition Name	CCAC.Comp.23	CCAC.Comp.24
Composition ID	CCAC.Comp.23	CCAC.Comp.24

Composition Source Data

Analysis Administration Data	
Name	CCAC.Comp.23
Description and Comments	CCAC.Comp.23
Creation Date	2015-10-04
Sample Date	N/A
Sample Type	Computed (Gas/Molar)
Substance Type	Unknown
Clearstone ID	CCAC.Comp.23

Analysis Results			
Component Name	Mole Fraction		
	Entered	Normalized	Air Free
Carbon dioxide	0.310322	0.310322	0.310322
Ethane	0.144248	0.144248	0.144248
Isobutane	0.000930	0.000930	0.000930
Isopentane	0.000600	0.000600	0.000600
Methane	0.475781	0.475781	0.475781
n-Butane	0.002354	0.002354	0.002354
n-Hexane	0.000316	0.000316	0.000316
Nitrogen	0.058442	0.058442	0.058442
n-Pentane	0.000630	0.000630	0.000630
Propane	0.006378	0.006378	0.006378
Total	1.000000	1.000000	1.000000

Composition Source Data

Analysis Administration Data	
Name	CCAC.Comp.24
Description and Comments	CCAC.Comp.24
Creation Date	2015-10-04
Sample Date	N/A
Sample Type	Computed (Gas/Molar)
Substance Type	Unknown
Clearstone ID	CCAC.Comp.24

Analysis Results			
Component Name	Mole Fraction		
	Entered	Normalized	Air Free
Isobutane	0.082951	0.082951	0.082951
Isopentane	0.053549	0.053549	0.053549
n-Butane	0.210019	0.210019	0.210019
n-Hexane	0.028188	0.028188	0.028188
n-Pentane	0.056221	0.056221	0.056221
Propane	0.569072	0.569072	0.569072
Total	1.000000	1.000000	1.000000

Production Decline Economics

Application Life (years)	Monetary Discount Rate (%/year)	Applied Production Decline Rate (%/year)	Assumed Inflation Rate (%/year)
10.0	10.0	15.0	0.0

Year	Revenues ¹ (USD)	Costs ¹ (USD)	Net Revenues (USD)	Net Present Value ² (USD)	ROI ³ (%)
0	0	14,400	-14,400	-14,400	—
1	1,498	416	1,082	984	7.5
1	1,498	416	1,082	984	7.5
1	1,498	416	1,082	984	7.5
1	1,498	416	1,082	984	7.5
2	1,308	416	893	738	6.2
2	1,308	416	893	738	6.2
2	1,308	416	893	738	6.2
2	1,308	416	893	738	6.2
3	1,142	416	727	546	5.0
3	1,142	416	727	546	5.0
3	1,142	416	727	546	5.0
3	1,142	416	727	546	5.0
4	998	416	582	397	4.0
4	998	416	582	397	4.0
4	998	416	582	397	4.0
4	998	416	582	397	4.0
5	871	416	455	283	3.2
5	871	416	455	283	3.2
5	871	416	455	283	3.2
5	871	416	455	283	3.2
6	761	416	345	195	2.4
6	761	416	345	195	2.4
6	761	416	345	195	2.4
6	761	416	345	195	2.4
7	664	416	249	128	1.7
7	664	416	249	128	1.7
7	664	416	249	128	1.7
7	664	416	249	128	1.7
8	580	416	164	77	1.1
8	580	416	164	77	1.1
8	580	416	164	77	1.1
8	580	416	164	77	1.1

9	507	416	91	39	0.6
9	507	416	91	39	0.6
9	507	416	91	39	0.6
9	507	416	91	39	0.6
10	442	416	27	10	0.2
10	442	416	27	10	0.2
10	442	416	27	10	0.2
10	442	416	27	10	0.2
Total	35,089	31,029	4,060	-816	3.2

¹ For year 0 Costs and Revenues represent capital cost and salvage values. For other years they represent operating cost and revenues in current year dollars.

² Net Present Value is expressed in Year-0 dollars.

³ ROI is current year net revenues over capital cost in Year-0 dollars. The Total row for this column is the median ROI value over the operating years.

Capital Cost Details

Control Technology Type	Application description
Vapour Recovery	Pesimistic cost

Cost Category	Cost Item Type	Item Description	Rate (USD/Unit)	Quantity (Unit)	Line Total (USD)
Lump sum	Lump sum	Cost (\$/m3/h)	14,400.00	1.0	14,400

Total 14,400

10 APPENDIX - GAS & VAPOUR ANALYSES

This section presents a copy of all the gas and vapour analyses performed during the completed field study and any such analyses provided by the facility operators.



Listing of Gas and Vapour Analyses Performed

Facility	Substance	Composition Name	Sample Date
CCAC.1	Process Gas	CCAC.Comp.35	2014-07-04
CCAC.2	Fuel Gas	CCAC.Comp.4	2014-01-01
CCAC.2	Unknown	CCAC.Comp.5	2015-08-31
CCAC.2	Unknown	CCAC.Comp.6	2015-09-01
CCAC.2	Unknown	CCAC.Comp.7	2015-08-31
CCAC.2	Waste Gas	CCAC.Comp.32	2014-01-01
CCAC.2	Waste Gas	CCAC.Comp.33	2013-10-15
CCAC.2	Waste Gas	CCAC.Comp.34	2014-01-01
CCAC.3	Process Gas	CCAC.Comp.9	2014-02-09
CCAC.4	Process Gas	CCAC.Comp.12	2013-03-20
CCAC.5	Process Gas	CCAC.Comp.14	2011-04-07
CCAC.6	Process Gas	CCAC.Comp.18	2011-11-30
CCAC.7	Process Gas	CCAC.Comp.29	2014-09-01
CCAC.7	Refinery Gas	CCAC.Comp.30	2013-09-02
CCAC.7	Unknown	CCAC.Comp.21	2015-06-30

Calculated or Reported Compositions

Facility	Substance	Composition Name	Data Entry Date
	Unknown	CCAC.Comp.16	2015-10-04
	Unknown	CCAC.Comp.17	2015-10-04
	Unknown	CCAC.Comp.23	2015-10-04
	Unknown	CCAC.Comp.24	2015-10-04
CCAC.1	Process Gas	CCAC.Comp.26	2014-12-10
CCAC.1	Unknown	CCAC.Comp.1	2015-11-30
CCAC.1	Waste Gas	CCAC.Comp.2	2014-12-10
CCAC.2	Unknown	CCAC.Comp.3	2015-11-03
CCAC.3	Process Gas	CCAC.Comp.22	2014-12-10
CCAC.3	Unknown	CCAC.Comp.8	2015-11-30
CCAC.3	Waste Gas	CCAC.Comp.10	2014-12-10
CCAC.4	Process Gas	CCAC.Comp.28	2014-12-10
CCAC.4	Unknown	CCAC.Comp.11	2015-12-02
CCAC.5	Sales Gas	CCAC.Comp.27	2014-12-10
CCAC.5	Unknown	CCAC.Comp.13	2015-11-30
CCAC.5	Waste Gas	CCAC.Comp.15	2014-12-10
CCAC.6	Tank Vapour	CCAC.Comp.25	2014-12-10

Calculated or Reported Compositions			
Facility	Substance	Composition Name	Data Entry Date
CCAC.6	Waste Gas	CCAC.Comp.19	2014-12-10
CCAC.7	Fuel Gas	CCAC.Comp.20	2014-12-10
CCAC.7	Waste Gas	CCAC.Comp.31	2014-12-10



Composition Source Data

Facility	
Clearstone Client	CCAC.1
Data Client	CCAC.1
Operator	CCAC.1
Name	CCAC.1
Location	CCAC.1
ID	CCAC.1
Category	Battery
Type	Oil Multi-Well
Government ID	CCAC.1
Operator BA Code	CCAC.1
Licensee BA Code	CCAC.1
Licensee Name	CCAC.1

Sample Data	
Name	CCAC.Comp.35
Description and Comments	CCAC.Comp.35
Data Entry Date	2014-12-03
Sample Date	2014-07-04
Sample Type	As Sampled (Gas/Molar)
Substance Type	Process Gas
Clearstone ID	CCAC.Comp.35

Analysis Results			
Component Name	Mole Fraction		
	Entered	Normalized	Air Free
Carbon dioxide	0.071988	0.071988	0.071988
Ethane	0.061346	0.061346	0.061346
Hydrogen sulfide	0.001246	0.001246	0.001246
Isobutane	0.009805	0.009805	0.009805
Isopentane	0.003358	0.003358	0.003358
Methane	0.797837	0.797837	0.797837
n-Butane	0.013726	0.013726	0.013726
n-Hexane	0.000111	0.000111	0.000111
Nitrogen	0.002725	0.002725	0.002725
n-Pentane	0.000246	0.000246	0.000246
Propane	0.037612	0.037612	0.037612
Total	1.000000	1.000000	1.000000



Composition Source Data

Facility	
Clearstone Client	CCAC.2
Data Client	CCAC.2
Operator	CCAC.2
Name	CCAC.2
Location	CCAC.2
ID	CCAC.2
Category	Tank Farm (Terminal)
Type	Pipeline
Government ID	CCAC.2
Operator BA Code	CCAC.2
Licensee BA Code	CCAC.2
Licensee Name	CCAC.2

Sample Data	
Name	CCAC.Comp.32
Description and Comments	CCAC.Comp.32
Data Entry Date	2014-12-04
Sample Date	2014-01-01
Sample Type	As Sampled (Gas/Molar)
Substance Type	Waste Gas
Clearstone ID	CCAC.Comp.32

Analysis Results			
Component Name	Mole Fraction		
	Entered	Normalized	Air Free
Benzene	0.000420	0.000420	0.000420
Carbon dioxide	0.028170	0.028170	0.028170
Ethane	0.114610	0.114610	0.114610
Hydrogen sulfide	0.016820	0.016820	0.016820
Isobutane	0.006960	0.006960	0.006960
Isopentane	0.004500	0.004500	0.004500
Methane	0.742110	0.742110	0.742110
m-Xylene	0.000010	0.000010	0.000010
n-Butane	0.017580	0.017580	0.017580
n-Heptane	0.003490	0.003490	0.003490
n-Hexane	0.001600	0.001600	0.001600
Nitrogen	0.004020	0.004020	0.004020
n-Nonane	0.000130	0.000130	0.000130
n-Octane	0.001040	0.001040	0.001040
n-Pentane	0.006010	0.006010	0.006010
n-Tetradecane	0.000010	0.000010	0.000010
n-Undecane	0.000010	0.000010	0.000010
o-Xylene	0.000020	0.000020	0.000020
Propane	0.052480	0.052480	0.052480
p-Xylene	0.000010	0.000010	0.000010
Total	1.000000	1.000000	1.000000



Composition Source Data

Facility	
Clearstone Client	CCAC.2
Data Client	CCAC.2
Operator	CCAC.2
Name	CCAC.2
Location	CCAC.2
ID	CCAC.2
Category	Tank Farm (Terminal)
Type	Pipeline
Government ID	CCAC.2
Operator BA Code	CCAC.2
Licensee BA Code	CCAC.2
Licensee Name	CCAC.2

Sample Data	
Name	CCAC.Comp.33
Description and Comments	CCAC.Comp.33
Data Entry Date	2014-12-04
Sample Date	2013-10-15
Sample Type	As Sampled (Gas/Molar)
Substance Type	Waste Gas
Clearstone ID	CCAC.Comp.33

Analysis Results			
Component Name	Mole Fraction		
	Entered	Normalized	Air Free
1-1-2-Trimethylcyclopenta	0.000732	0.000732	0.000734
1-1-3-Trimethylcyclopenta	0.001164	0.001164	0.001167
1-1-Dimethylcyclopentane	0.001184	0.001184	0.001187
1-2-Dimethylcyclohexane-t	0.000076	0.000076	0.000076
1-2-Dimethylcyclopentane	0.002489	0.002488	0.002495
1-2-Dimethylcyclopentane	0.003977	0.003976	0.003986
1-3-Dimethylcyclohexane-c	0.000070	0.000070	0.000070
1-3-Dimethylcyclohexane-t	0.002325	0.002325	0.002330
1-4-Dimethylcyclohexane-t	0.001179	0.001179	0.001182
2-2-3-Trimethylbutane	0.000117	0.000117	0.000117
2-2-3-Trimethylhexane	0.000037	0.000037	0.000037
2-2-4-4-Tetramethylpentar	0.000494	0.000494	0.000495
2-2-4-Trimethylhexane	0.000235	0.000235	0.000236
2-2-4-Trimethylpentane	0.000007	0.000007	0.000007
2-2-5-Trimethylhexane	0.000045	0.000045	0.000045
2-2-Dimethyl butane	0.000434	0.000434	0.000435
2-2-Dimethylheptane	0.001164	0.001164	0.001167
2-2-Dimethylpentane	0.007077	0.007076	0.007094
2-3-4-Trimethylpentane	0.000201	0.000201	0.000201
2-3-Dimethyl butane	0.002123	0.002123	0.002128
2-3-Dimethylpentane	0.000446	0.000446	0.000447
2-4-Dimethylhexane	0.000218	0.000218	0.000219

Analysis Results			
Component Name	Mole Fraction		
	Entered	Normalized	Air Free
2-4-Dimethylpentane	0.002501	0.002500	0.002507
2-5-Dimethylhexane	0.000383	0.000383	0.000384
2-Methyl pentane	0.150425	0.150394	0.150776
2-Methyl-3-ethylpentane	0.000596	0.000596	0.000597
2-Methylheptane	0.000651	0.000651	0.000653
2-Methylhexane	0.000284	0.000284	0.000285
2-Methyloctane	0.000105	0.000105	0.000105
3-3-Dimethylhexane	0.000193	0.000193	0.000193
3-4-Dimethylhexane	0.000248	0.000248	0.000249
3-Ethylpentane	0.000259	0.000259	0.000260
3-Methyl pentane	0.008500	0.008498	0.008520
3-Methylheptane	0.000401	0.000401	0.000402
3-Methylhexane	0.003288	0.003287	0.003296
4-Methylheptane	0.000191	0.000191	0.000191
Benzene	0.001825	0.001825	0.001829
Carbon dioxide	0.017381	0.017377	0.017422
Cyclohexane	0.002884	0.002883	0.002891
Cyclooctane	0.000059	0.000059	0.000059
Cyclopentane	0.002616	0.002615	0.002622
Ethane	0.140767	0.140738	0.141096
Ethylbenzene	0.000090	0.000090	0.000090
Hydrogen sulfide	0.023258	0.023253	0.023312
Isobutane	0.035909	0.035901	0.035993
Isopentane	0.041238	0.041229	0.041334
Methane	0.142937	0.142907	0.143271
Methylcyclohexane	0.000144	0.000144	0.000144
Methylcyclopentane	0.004687	0.004686	0.004698
m-Xylene	0.000141	0.000141	0.000141
n-Butane	0.116211	0.116187	0.116482
Neopentane	0.000700	0.000700	0.000702
n-Heptane	0.006673	0.006672	0.006689
n-Hexane	0.022373	0.022368	0.022425
Nitrogen	0.007865	0.007863	0.005877
n-Nonane	0.000337	0.000337	0.000338
n-Octane	0.001340	0.001340	0.001343
n-Pentane	0.056803	0.056791	0.056936
n-Propylcyclohexane	0.000043	0.000043	0.000043
n-Propylcyclopentane	0.000316	0.000316	0.000317
Oxygen	0.000537	0.000537	0.000000
o-Xylene	0.000049	0.000049	0.000049
Propane	0.177444	0.177407	0.177858
p-Xylene	0.000054	0.000054	0.000054
Toluene	0.001709	0.001709	0.001713
Total	1.000209	1.000000	1.000000



Composition Source Data

Facility	
Clearstone Client	CCAC.2
Data Client	CCAC.2
Operator	CCAC.2
Name	CCAC.2
Location	CCAC.2
ID	CCAC.2
Category	Tank Farm (Terminal)
Type	Pipeline
Government ID	CCAC.2
Operator BA Code	CCAC.2
Licensee BA Code	CCAC.2
Licensee Name	CCAC.2

Sample Data	
Name	CCAC.Comp.34
Description and Comments	CCAC.Comp.34
Data Entry Date	2014-12-04
Sample Date	2014-01-01
Sample Type	As Sampled (Gas/Molar)
Substance Type	Waste Gas
Clearstone ID	CCAC.Comp.34

Analysis Results			
Component Name	Mole Fraction		
	Entered	Normalized	Air Free
Benzene	0.001250	0.001250	0.001250
Carbon dioxide	0.015760	0.015760	0.015760
Ethane	0.187140	0.187140	0.187140
Hydrogen sulfide	0.022960	0.022960	0.022960
Isobutane	0.043190	0.043190	0.043190
Isopentane	0.044440	0.044440	0.044440
Methane	0.166970	0.166970	0.166970
m-Xylene	0.000070	0.000070	0.000070
n-Butane	0.140700	0.140700	0.140700
n-Decane	0.000350	0.000350	0.000350
n-Heptane	0.042790	0.042790	0.042790
n-Hexane	0.025420	0.025420	0.025420
n-Nonane	0.002490	0.002490	0.002490
n-Octane	0.009130	0.009130	0.009130
n-Pentane	0.058150	0.058150	0.058150
n-Undecane	0.000070	0.000070	0.000070
Propane	0.237750	0.237750	0.237750
p-Xylene	0.000070	0.000070	0.000070
Toluene	0.001300	0.001300	0.001300
Total	1.000000	1.000000	1.000000



Composition Source Data

Facility	
Clearstone Client	CCAC.2
Data Client	CCAC.2
Operator	CCAC.2
Name	CCAC.2
Location	CCAC.2
ID	CCAC.2
Category	Tank Farm (Terminal)
Type	Pipeline
Government ID	CCAC.2
Operator BA Code	CCAC.2
Licensee BA Code	CCAC.2
Licensee Name	CCAC.2

Sample Data	
Name	CCAC.Comp.4
Description and Comments	CCAC.Comp.4
Data Entry Date	2014-12-04
Sample Date	2014-01-01
Sample Type	As Sampled (Gas/Molar)
Substance Type	Fuel Gas
Clearstone ID	CCAC.Comp.4

Analysis Results			
Component Name	Mole Fraction		
	Entered	Normalized	Air Free
Benzene	0.000080	0.000080	0.000080
Carbon dioxide	0.004630	0.004630	0.004630
Ethane	0.183620	0.183620	0.183620
Ethylbenzene	0.000010	0.000010	0.000010
Isobutane	0.011710	0.011710	0.011710
Isopentane	0.007340	0.007340	0.007340
Methane	0.592920	0.592920	0.592920
m-Xylene	0.000005	0.000005	0.000005
n-Butane	0.032550	0.032550	0.032550
n-Heptane	0.002650	0.002650	0.002650
n-Hexane	0.004430	0.004430	0.004430
Nitrogen	0.044090	0.044090	0.044090
n-Nonane	0.000020	0.000020	0.000020
n-Octane	0.000320	0.000320	0.000320
n-Pentane	0.009190	0.009190	0.009190
Propane	0.106370	0.106370	0.106370
p-Xylene	0.000005	0.000005	0.000005
Toluene	0.000060	0.000060	0.000060
Total	1.000000	1.000000	1.000000



Composition Source Data

Facility	
Clearstone Client	CCAC.2
Data Client	CCAC.2
Operator	CCAC.2
Name	CCAC.2
Location	CCAC.2
ID	CCAC.2
Category	Tank Farm (Terminal)
Type	Pipeline
Government ID	CCAC.2
Operator BA Code	CCAC.2
Licensee BA Code	CCAC.2
Licensee Name	CCAC.2

Sample Data	
Name	CCAC.Comp.6
Description and Comments	CCAC.Comp.6
Data Entry Date	2015-09-27
Sample Date	2015-09-01
Sample Type	As Sampled (Gas/Molar)
Substance Type	Unknown
Clearstone ID	CCAC.Comp.6

Analysis Results			
Component Name	Mole Fraction		
	Entered	Normalized	Air Free
Ethane	0.225206	0.225185	0.225185
Hydrogen sulfide	0.047756	0.047751	0.047751
Isobutane	0.057846	0.057840	0.057840
Methane	0.310996	0.310968	0.310968
n-Butane	0.156145	0.156130	0.156130
n-Pentane	0.003595	0.003595	0.003595
Propane	0.198548	0.198530	0.198530
Total	1.000090	1.000000	1.000000



Composition Source Data

Facility	
Clearstone Client	CCAC.2
Data Client	CCAC.2
Operator	CCAC.2
Name	CCAC.2
Location	CCAC.2
ID	CCAC.2
Category	Tank Farm (Terminal)
Type	Pipeline
Government ID	CCAC.2
Operator BA Code	CCAC.2
Licensee BA Code	CCAC.2
Licensee Name	CCAC.2

Sample Data	
Name	CCAC.Comp.7
Description and Comments	CCAC.Comp.7
Data Entry Date	2015-09-27
Sample Date	2015-08-31
Sample Type	As Sampled (Gas/Molar)
Substance Type	Unknown
Clearstone ID	CCAC.Comp.7

Analysis Results			
Component Name	Mole Fraction		
	Entered	Normalized	Air Free
Carbon dioxide	0.000870	0.000870	0.000870
Ethane	0.277725	0.277735	0.277735
Hydrogen sulfide	0.021278	0.021279	0.021279
Isobutane	0.021139	0.021140	0.021140
Methane	0.436533	0.436548	0.436548
n-Butane	0.061224	0.061226	0.061226
Nitrogen	0.017000	0.017001	0.017001
n-Pentane	0.005364	0.005364	0.005364
Propane	0.158831	0.158837	0.158837
Total	0.999965	1.000000	1.000000



Composition Source Data

Facility	
Clearstone Client	CCAC.3
Data Client	CCAC.3
Operator	CCAC.3
Name	CCAC.3
Location	CCAC.3
ID	CCAC.3
Category	Battery
Type	Oil Multi-Well
Government ID	CCAC.3
Operator BA Code	CCAC.3
Licensee BA Code	CCAC.3
Licensee Name	CCAC.3

Sample Data	
Name	CCAC.Comp.9
Description and Comments	CCAC.Comp.9
Data Entry Date	2014-12-04
Sample Date	2014-02-09
Sample Type	As Sampled (Gas/Molar)
Substance Type	Process Gas
Clearstone ID	CCAC.Comp.9

Analysis Results			
Component Name	Mole Fraction		
	Entered	Normalized	Air Free
Carbon dioxide	0.159934	0.159934	0.159934
Ethane	0.091561	0.091561	0.091561
Isobutane	0.008409	0.008409	0.008409
Isopentane	0.002543	0.002543	0.002543
Methane	0.650658	0.650658	0.650658
n-Butane	0.018011	0.018011	0.018011
n-Hexane	0.000097	0.000097	0.000097
Nitrogen	0.001254	0.001254	0.001254
n-Pentane	0.002041	0.002041	0.002041
Propane	0.065492	0.065492	0.065492
Total	1.000000	1.000000	1.000000



Composition Source Data

Facility	
Clearstone Client	CCAC.4
Data Client	CCAC.4
Operator	CCAC.4
Name	CCAC.4
Location	CCAC.4
ID	CCAC.4
Category	Battery
Type	Oil Multi-Well
Government ID	CCAC.4
Operator BA Code	CCAC.4
Licensee BA Code	CCAC.4
Licensee Name	CCAC.4

Sample Data	
Name	CCAC.Comp.12
Description and Comments	CCAC.Comp.12
Data Entry Date	2014-12-04
Sample Date	2013-03-20
Sample Type	As Sampled (Gas/Molar)
Substance Type	Process Gas
Clearstone ID	CCAC.Comp.12

Analysis Results			
Component Name	Mole Fraction		
	Entered	Normalized	Air Free
Carbon dioxide	0.212420	0.212420	0.212420
Ethane	0.093276	0.093276	0.093276
Hydrogen sulfide	0.003568	0.003568	0.003568
Isobutane	0.008429	0.008429	0.008429
Isopentane	0.004485	0.004485	0.004485
Methane	0.564001	0.564001	0.564001
n-Butane	0.026089	0.026089	0.026089
n-Hexane	0.000281	0.000281	0.000281
Nitrogen	0.011426	0.011426	0.011426
n-Pentane	0.004571	0.004571	0.004571
Propane	0.071454	0.071454	0.071454
Total	1.000000	1.000000	1.000000



Composition Source Data

Facility	
Clearstone Client	CCAC.5
Data Client	CCAC.5
Operator	CCAC.5
Name	CCAC.5
Location	CCAC.5
ID	CCAC.5
Category	Battery
Type	Oil Multi-Well
Government ID	CCAC.5
Operator BA Code	CCAC.5
Licensee BA Code	CCAC.5
Licensee Name	CCAC.5

Sample Data	
Name	CCAC.Comp.14
Description and Comments	CCAC.Comp.14
Data Entry Date	2014-12-04
Sample Date	2011-04-07
Sample Type	As Sampled (Gas/Molar)
Substance Type	Process Gas
Clearstone ID	CCAC.Comp.14

Analysis Results			
Component Name	Mole Fraction		
	Entered	Normalized	Air Free
Carbon dioxide	0.098490	0.098490	0.098490
Ethane	0.094905	0.094905	0.094905
Isobutane	0.008208	0.008208	0.008208
Isopentane	0.007199	0.007199	0.007199
Methane	0.665144	0.665144	0.665144
n-Butane	0.022617	0.022617	0.022617
n-Hexane	0.005687	0.005687	0.005687
Nitrogen	0.049576	0.049576	0.049576
n-Pentane	0.007506	0.007506	0.007506
Propane	0.040668	0.040668	0.040668
Total	1.000000	1.000000	1.000000



Composition Source Data

Facility	
Clearstone Client	CCAC.6
Data Client	CCAC.6
Operator	CCAC.6
Name	CCAC.6
Location	CCAC.6
ID	CCAC.6
Category	Battery
Type	Oil Multi-Well
Government ID	CCAC.6
Operator BA Code	CCAC.6
Licensee BA Code	CCAC.6
Licensee Name	CCAC.6

Sample Data	
Name	CCAC.Comp.18
Description and Comments	CCAC.Comp.18
Data Entry Date	2014-12-04
Sample Date	2011-11-30
Sample Type	As Sampled (Gas/Molar)
Substance Type	Process Gas
Clearstone ID	CCAC.Comp.18

Analysis Results			
Component Name	Mole Fraction		
	Entered	Normalized	Air Free
Carbon dioxide	0.231608	0.231608	0.231608
Ethane	0.107659	0.107659	0.107659
Isobutane	0.013878	0.013878	0.013878
Isopentane	0.008959	0.008959	0.008959
Methane	0.449811	0.449811	0.449811
n-Butane	0.035137	0.035137	0.035137
n-Hexane	0.004716	0.004716	0.004716
Nitrogen	0.043618	0.043618	0.043618
n-Pentane	0.009406	0.009406	0.009406
Propane	0.095208	0.095208	0.095208
Total	1.000000	1.000000	1.000000



Composition Source Data

Facility	
Clearstone Client	CCAC.7
Data Client	CCAC.7
Operator	CCAC.7
Name	CCAC.7
Location	CCAC.7
ID	CCAC.7
Category	Compressor Station
Type	Gas Transmission
Government ID	CCAC.7
Operator BA Code	CCAC.7
Licensee BA Code	CCAC.7
Licensee Name	CCAC.7

Sample Data	
Name	CCAC.Comp.21
Description and Comments	CCAC.Comp.21
Data Entry Date	2015-08-23
Sample Date	2015-06-30
Sample Type	As Sampled (Gas/Molar)
Substance Type	Unknown
Clearstone ID	CCAC.Comp.21

Analysis Results			
Component Name	Mole Fraction		
	Entered	Normalized	Air Free
Carbon dioxide	0.000000	0.000000	0.000000
Ethane	0.092134	0.092134	0.092134
Hydrogen sulfide	0.001076	0.001076	0.001076
Isobutane	0.002407	0.002407	0.002407
Methane	0.679734	0.679734	0.679734
n-Butane	0.003645	0.003645	0.003645
Nitrogen	0.161285	0.161285	0.161285
n-Pentane	0.000000	0.000000	0.000000
Propane	0.009720	0.009720	0.009720
Water	0.050000	0.050000	0.050000
Total	1.000000	1.000000	1.000000



Composition Source Data

Facility	
Clearstone Client	CCAC.7
Data Client	CCAC.7
Operator	CCAC.7
Name	CCAC.7
Location	CCAC.7
ID	CCAC.7
Category	Compressor Station
Type	Gas Transmission
Government ID	CCAC.7
Operator BA Code	CCAC.7
Licensee BA Code	CCAC.7
Licensee Name	CCAC.7

Sample Data	
Name	CCAC.Comp.29
Description and Comments	CCAC.Comp.29
Data Entry Date	2014-12-04
Sample Date	2014-09-01
Sample Type	As Sampled (Gas/Molar)
Substance Type	Process Gas
Clearstone ID	CCAC.Comp.29

Analysis Results			
Component Name	Mole Fraction		
	Entered	Normalized	Air Free
Carbon dioxide	0.004900	0.004900	0.004900
Ethane	0.091500	0.091500	0.091500
Hydrogen sulfide	0.009900	0.009900	0.009900
Isobutane	0.046000	0.046000	0.046000
Isopentane	0.082900	0.082900	0.082900
Methane	0.034200	0.034200	0.034200
n-Butane	0.150100	0.150100	0.150100
n-Hexane	0.312300	0.312300	0.312300
Nitrogen	0.000400	0.000400	0.000400
n-Pentane	0.125300	0.125300	0.125300
Propane	0.142500	0.142500	0.142500
Total	1.000000	1.000000	1.000000



Composition Source Data

Facility	
Clearstone Client	CCAC.7
Data Client	CCAC.7
Operator	CCAC.7
Name	CCAC.7
Location	CCAC.7
ID	CCAC.7
Category	Compressor Station
Type	Gas Transmission
Government ID	CCAC.7
Operator BA Code	CCAC.7
Licensee BA Code	CCAC.7
Licensee Name	CCAC.7

Sample Data	
Name	CCAC.Comp.30
Description and Comments	CCAC.Comp.30
Data Entry Date	2014-12-04
Sample Date	2013-09-02
Sample Type	As Sampled (Gas/Molar)
Substance Type	Refinery Gas
Clearstone ID	CCAC.Comp.30

Analysis Results			
Component Name	Mole Fraction		
	Entered	Normalized	Air Free
1-2-Dimethylcyclopentane	0.000100	0.000100	0.000100
1-2-Dimethylcyclopentane	0.000200	0.000200	0.000200
2-3-Dimethylpentane	0.000100	0.000100	0.000100
2-4-Dimethylpentane	0.000100	0.000100	0.000100
2-Methyl pentane	0.000800	0.000800	0.000801
2-Methylhexane	0.000100	0.000100	0.000100
3-Methyl pentane	0.000400	0.000400	0.000400
3-Methylhexane	0.000100	0.000100	0.000100
Benzene	0.000100	0.000100	0.000100
Carbon dioxide	0.024100	0.024095	0.024118
Cyclohexane	0.000100	0.000100	0.000100
Cyclopentane	0.000200	0.000200	0.000200
Ethane	0.132600	0.132573	0.132699
Hydrogen sulfide	0.018400	0.018396	0.018414
Isobutane	0.008200	0.008198	0.008206
Isopentane	0.004800	0.004799	0.004804
Methane	0.601500	0.601380	0.601949
Methylcyclopentane	0.000200	0.000200	0.000200
n-Butane	0.022400	0.022396	0.022417
Neopentane	0.000100	0.000100	0.000100
n-Heptane	0.000100	0.000100	0.000100
n-Hexane	0.001100	0.001100	0.001101

Analysis Results				
Component Name	Mole Fraction			
	Entered	Normalized	Air Free	
Nitrogen	0.112800	0.112777	0.112138	
n-Pentane	0.006000	0.005999	0.006004	
Oxygen	0.000200	0.000200	0.000000	
Propane	0.065400	0.065387	0.065449	
Total	1.000200	1.000000	1.000000	



Composition Source Data

Facility	
Clearstone Client	CCAC
Data Client	CCAC
Operator	
Name	
Location	
ID	
Category	
Type	
Government ID	
Operator BA Code	
Licensee BA Code	
Licensee Name	

Sample Data	
Name	CCAC.Comp.16
Description and Comments	CCAC.Comp.16
Data Entry Date	2015-10-04
Sample Date	N/A
Sample Type	Computed (Gas/Molar)
Substance Type	Unknown
Clearstone ID	CCAC.Comp.16

Analysis Results			
Component Name	Mole Fraction		
	Entered	Normalized	Air Free
Carbon dioxide	0.310322	0.310322	0.310322
Ethane	0.144248	0.144248	0.144248
Isobutane	0.000930	0.000930	0.000930
Isopentane	0.000600	0.000600	0.000600
Methane	0.475781	0.475781	0.475781
n-Butane	0.002354	0.002354	0.002354
n-Hexane	0.000316	0.000316	0.000316
Nitrogen	0.058442	0.058442	0.058442
n-Pentane	0.000630	0.000630	0.000630
Propane	0.006378	0.006378	0.006378
Total	1.000000	1.000000	1.000000



Composition Source Data

Facility	
Clearstone Client	CCAC
Data Client	CCAC
Operator	
Name	
Location	
ID	
Category	
Type	
Government ID	
Operator BA Code	
Licensee BA Code	
Licensee Name	

Sample Data	
Name	CCAC.Comp.17
Description and Comments	CCAC.Comp.17
Data Entry Date	2015-10-04
Sample Date	N/A
Sample Type	Computed (Gas/Molar)
Substance Type	Unknown
Clearstone ID	CCAC.Comp.17

Analysis Results			
Component Name	Mole Fraction		
	Entered	Normalized	Air Free
Isobutane	0.082951	0.082951	0.082951
Isopentane	0.053549	0.053549	0.053549
n-Butane	0.210019	0.210019	0.210019
n-Hexane	0.028188	0.028188	0.028188
n-Pentane	0.056221	0.056221	0.056221
Propane	0.569072	0.569072	0.569072
Total	1.000000	1.000000	1.000000



Composition Source Data

Facility	
Clearstone Client	CCAC
Data Client	CCAC
Operator	
Name	
Location	
ID	
Category	
Type	
Government ID	
Operator BA Code	
Licensee BA Code	
Licensee Name	

Sample Data	
Name	CCAC.Comp.23
Description and Comments	CCAC.Comp.23
Data Entry Date	2015-10-04
Sample Date	N/A
Sample Type	Computed (Gas/Molar)
Substance Type	Unknown
Clearstone ID	CCAC.Comp.23

Analysis Results			
Component Name	Mole Fraction		
	Entered	Normalized	Air Free
Carbon dioxide	0.310322	0.310322	0.310322
Ethane	0.144248	0.144248	0.144248
Isobutane	0.000930	0.000930	0.000930
Isopentane	0.000600	0.000600	0.000600
Methane	0.475781	0.475781	0.475781
n-Butane	0.002354	0.002354	0.002354
n-Hexane	0.000316	0.000316	0.000316
Nitrogen	0.058442	0.058442	0.058442
n-Pentane	0.000630	0.000630	0.000630
Propane	0.006378	0.006378	0.006378
Total	1.000000	1.000000	1.000000



Composition Source Data

Facility	
Clearstone Client	CCAC
Data Client	CCAC
Operator	
Name	
Location	
ID	
Category	
Type	
Government ID	
Operator BA Code	
Licensee BA Code	
Licensee Name	

Sample Data	
Name	CCAC.Comp.24
Description and Comments	CCAC.Comp.24
Data Entry Date	2015-10-04
Sample Date	N/A
Sample Type	Computed (Gas/Molar)
Substance Type	Unknown
Clearstone ID	CCAC.Comp.24

Analysis Results			
Component Name	Mole Fraction		
	Entered	Normalized	Air Free
Isobutane	0.082951	0.082951	0.082951
Isopentane	0.053549	0.053549	0.053549
n-Butane	0.210019	0.210019	0.210019
n-Hexane	0.028188	0.028188	0.028188
n-Pentane	0.056221	0.056221	0.056221
Propane	0.569072	0.569072	0.569072
Total	1.000000	1.000000	1.000000



Composition Source Data

Facility	
Clearstone Client	CCAC.1
Data Client	CCAC.1
Operator	CCAC.1
Name	CCAC.1
Location	CCAC.1
ID	CCAC.1
Category	Battery
Type	Oil Multi-Well
Government ID	CCAC.1
Operator BA Code	CCAC.1
Licensee BA Code	CCAC.1
Licensee Name	CCAC.1

Sample Data	
Name	CCAC.Comp.1
Description and Comments	CCAC.Comp.1
Data Entry Date	2015-11-30
Sample Date	N/A
Sample Type	Computed (Gas/Molar)
Substance Type	Unknown
Clearstone ID	CCAC.Comp.1

Analysis Results			
Component Name	Mole Fraction		
	Entered	Normalized	Air Free
Ethane	0.073284	0.073284	0.073284
Isobutane	0.178816	0.178816	0.178816
Isopentane	0.105032	0.105032	0.105032
Methane	0.048565	0.048565	0.048565
n-Butane	0.305799	0.305799	0.305799
n-Hexane	0.004113	0.004113	0.004113
Nitrogen	0.000019	0.000019	0.000019
n-Pentane	0.007990	0.007990	0.007990
Propane	0.276382	0.276382	0.276382
Total	1.000000	1.000000	1.000000



Composition Source Data

Facility	
Clearstone Client	CCAC.1
Data Client	CCAC.1
Operator	CCAC.1
Name	CCAC.1
Location	CCAC.1
ID	CCAC.1
Category	Battery
Type	Oil Multi-Well
Government ID	CCAC.1
Operator BA Code	CCAC.1
Licensee BA Code	CCAC.1
Licensee Name	CCAC.1

Sample Data	
Name	CCAC.Comp.2
Description and Comments	CCAC.Comp.2
Data Entry Date	2014-12-10
Sample Date	N/A
Sample Type	Computed (Gas/Molar)
Substance Type	Waste Gas
Clearstone ID	CCAC.Comp.2

Analysis Results			
Component Name	Mole Fraction		
	Entered	Normalized	Air Free
Carbon dioxide	0.061814	0.061814	0.061814
Ethane	0.052676	0.052676	0.052676
Hydrogen sulfide	0.001070	0.001070	0.001070
Isobutane	0.008419	0.008419	0.008419
Isopentane	0.002883	0.002883	0.002883
Methane	0.826408	0.826408	0.826408
n-Butane	0.011786	0.011786	0.011786
n-Hexane	0.000095	0.000095	0.000095
Nitrogen	0.002340	0.002340	0.002340
n-Pentane	0.000211	0.000211	0.000211
Propane	0.032296	0.032296	0.032296
Total	1.000000	1.000000	1.000000



Composition Source Data

Facility	
Clearstone Client	CCAC.1
Data Client	CCAC.1
Operator	CCAC.1
Name	CCAC.1
Location	CCAC.1
ID	CCAC.1
Category	Battery
Type	Oil Multi-Well
Government ID	CCAC.1
Operator BA Code	CCAC.1
Licensee BA Code	CCAC.1
Licensee Name	CCAC.1

Sample Data	
Name	CCAC.Comp.26
Description and Comments	CCAC.Comp.26
Data Entry Date	2014-12-10
Sample Date	N/A
Sample Type	Computed (Gas/Molar)
Substance Type	Process Gas
Clearstone ID	CCAC.Comp.26

Analysis Results			
Component Name	Mole Fraction		
	Entered	Normalized	Air Free
Benzene	0.004427	0.004427	0.004427
Cyclohexane	0.008808	0.008808	0.008808
Dodecane	0.055442	0.055442	0.055442
Ethylbenzene	0.009565	0.009565	0.009565
Hexadecane	0.035986	0.035986	0.035986
Isobutane	0.000963	0.000963	0.000963
Isopentane	0.005237	0.005237	0.005237
Methylcyclohexane	0.009264	0.009264	0.009264
Methylcyclopentane	0.005975	0.005975	0.005975
n-Butane	0.005000	0.005000	0.005000
n-Decane	0.075602	0.075602	0.075602
n-Eicosane	0.276139	0.276139	0.276139
n-Heptadecane	0.031271	0.031271	0.031271
n-Heptane	0.037619	0.037619	0.037619
n-Hexane	0.029733	0.029733	0.029733
n-Nonadecane	0.027333	0.027333	0.027333
n-Nonane	0.052094	0.052094	0.052094
n-Octane	0.054558	0.054558	0.054558
n-Pentadecane	0.042085	0.042085	0.042085
n-Pentane	0.010327	0.010327	0.010327
n-Tetradecane	0.044131	0.044131	0.044131
n-Tridecane	0.051413	0.051413	0.051413

Analysis Results			
Component Name	Mole Fraction		
	Entered	Normalized	Air Free
n-Undecane	0.063968	0.063968	0.063968
Octadecane	0.029765	0.029765	0.029765
o-Xylene	0.007875	0.007875	0.007875
Propane	0.005595	0.005595	0.005595
p-Xylene	0.007035	0.007035	0.007035
Toluene	0.012790	0.012790	0.012790
Total	1.000000	1.000000	1.000000



Composition Source Data

Facility	
Clearstone Client	CCAC.2
Data Client	CCAC.2
Operator	CCAC.2
Name	CCAC.2
Location	CCAC.2
ID	CCAC.2
Category	Tank Farm (Terminal)
Type	Pipeline
Government ID	CCAC.2
Operator BA Code	CCAC.2
Licensee BA Code	CCAC.2
Licensee Name	CCAC.2

Sample Data	
Name	CCAC.Comp.3
Description and Comments	CCAC.Comp.3
Data Entry Date	2015-11-03
Sample Date	N/A
Sample Type	As Sampled (Gas/Molar)
Substance Type	Unknown
Clearstone ID	CCAC.Comp.3

Analysis Results			
Component Name	Mole Fraction		
	Entered	Normalized	Air Free
Methane	1.000000	1.000000	1.000000
Total	1.000000	1.000000	1.000000



Composition Source Data

Facility	
Clearstone Client	CCAC.3
Data Client	CCAC.3
Operator	CCAC.3
Name	CCAC.3
Location	CCAC.3
ID	CCAC.3
Category	Battery
Type	Oil Multi-Well
Government ID	CCAC.3
Operator BA Code	CCAC.3
Licensee BA Code	CCAC.3
Licensee Name	CCAC.3

Sample Data	
Name	CCAC.Comp.10
Description and Comments	CCAC.Comp.10
Data Entry Date	2014-12-10
Sample Date	N/A
Sample Type	Computed (Gas/Molar)
Substance Type	Waste Gas
Clearstone ID	CCAC.Comp.10

Analysis Results			
Component Name	Mole Fraction		
	Entered	Normalized	Air Free
Carbon dioxide	0.231820	0.231815	0.231815
Ethane	0.132710	0.132707	0.132707
Isobutane	0.012190	0.012190	0.012190
Isopentane	0.003690	0.003690	0.003690
Methane	0.493650	0.493640	0.493640
n-Butane	0.026110	0.026109	0.026109
n-Hexane	0.000140	0.000140	0.000140
Nitrogen	0.001820	0.001820	0.001820
n-Pentane	0.002960	0.002960	0.002960
Propane	0.094930	0.094928	0.094928
Total	1.000020	1.000000	1.000000



Composition Source Data

Facility	
Clearstone Client	CCAC.3
Data Client	CCAC.3
Operator	CCAC.3
Name	CCAC.3
Location	CCAC.3
ID	CCAC.3
Category	Battery
Type	Oil Multi-Well
Government ID	CCAC.3
Operator BA Code	CCAC.3
Licensee BA Code	CCAC.3
Licensee Name	CCAC.3

Sample Data	
Name	CCAC.Comp.22
Description and Comments	CCAC.Comp.22
Data Entry Date	2014-12-10
Sample Date	N/A
Sample Type	Computed (Gas/Molar)
Substance Type	Process Gas
Clearstone ID	CCAC.Comp.22

Analysis Results			
Component Name	Mole Fraction		
	Entered	Normalized	Air Free
Benzene	0.004427	0.004427	0.004427
Cyclohexane	0.008808	0.008808	0.008808
Dodecane	0.055442	0.055442	0.055442
Ethylbenzene	0.009565	0.009565	0.009565
Hexadecane	0.035986	0.035986	0.035986
Isobutane	0.000963	0.000963	0.000963
Isopentane	0.005237	0.005237	0.005237
Methylcyclohexane	0.009264	0.009264	0.009264
Methylcyclopentane	0.005975	0.005975	0.005975
n-Butane	0.005000	0.005000	0.005000
n-Decane	0.075602	0.075602	0.075602
n-Eicosane	0.276139	0.276139	0.276139
n-Heptadecane	0.031271	0.031271	0.031271
n-Heptane	0.037619	0.037619	0.037619
n-Hexane	0.029733	0.029733	0.029733
n-Nonadecane	0.027333	0.027333	0.027333
n-Nonane	0.052094	0.052094	0.052094
n-Octane	0.054558	0.054558	0.054558
n-Pentadecane	0.042085	0.042085	0.042085
n-Pentane	0.010327	0.010327	0.010327
n-Tetradecane	0.044131	0.044131	0.044131
n-Tridecane	0.051413	0.051413	0.051413

Analysis Results			
Component Name	Mole Fraction		
	Entered	Normalized	Air Free
n-Undecane	0.063968	0.063968	0.063968
Octadecane	0.029765	0.029765	0.029765
o-Xylene	0.007875	0.007875	0.007875
Propane	0.005595	0.005595	0.005595
p-Xylene	0.007035	0.007035	0.007035
Toluene	0.012790	0.012790	0.012790
Total	1.000000	1.000000	1.000000



Composition Source Data

Facility	
Clearstone Client	CCAC.3
Data Client	CCAC.3
Operator	CCAC.3
Name	CCAC.3
Location	CCAC.3
ID	CCAC.3
Category	Battery
Type	Oil Multi-Well
Government ID	CCAC.3
Operator BA Code	CCAC.3
Licensee BA Code	CCAC.3
Licensee Name	CCAC.3

Sample Data	
Name	CCAC.Comp.8
Description and Comments	CCAC.Comp.8
Data Entry Date	2015-11-30
Sample Date	N/A
Sample Type	Computed (Gas/Molar)
Substance Type	Unknown
Clearstone ID	CCAC.Comp.8

Analysis Results			
Component Name	Mole Fraction		
	Entered	Normalized	Air Free
Carbon dioxide	0.048202	0.048202	0.048202
Ethane	0.099997	0.099997	0.099997
Isobutane	0.103537	0.103537	0.103537
Isopentane	0.051608	0.051608	0.051608
Methane	0.015015	0.015015	0.015015
n-Butane	0.257026	0.257026	0.257026
n-Hexane	0.002519	0.002519	0.002519
Nitrogen	0.000007	0.000007	0.000007
n-Pentane	0.042687	0.042687	0.042687
Propane	0.379402	0.379402	0.379402
Total	1.000000	1.000000	1.000000



Composition Source Data

Facility	
Clearstone Client	CCAC.4
Data Client	CCAC.4
Operator	CCAC.4
Name	CCAC.4
Location	CCAC.4
ID	CCAC.4
Category	Battery
Type	Oil Multi-Well
Government ID	CCAC.4
Operator BA Code	CCAC.4
Licensee BA Code	CCAC.4
Licensee Name	CCAC.4

Sample Data	
Name	CCAC.Comp.11
Description and Comments	CCAC.Comp.11
Data Entry Date	2015-12-02
Sample Date	N/A
Sample Type	Computed (Gas/Molar)
Substance Type	Unknown
Clearstone ID	CCAC.Comp.11

Analysis Results			
Component Name	Mole Fraction		
	Entered	Normalized	Air Free
Ethane	0.126781	0.126781	0.126781
Isobutane	0.075414	0.075414	0.075414
Isopentane	0.044935	0.044935	0.044935
Methane	0.029849	0.029849	0.029849
n-Butane	0.244098	0.244098	0.244098
n-Hexane	0.002889	0.002889	0.002889
Nitrogen	0.000075	0.000075	0.000075
n-Pentane	0.046061	0.046061	0.046061
Propane	0.429898	0.429898	0.429898
Total	1.000000	1.000000	1.000000



Composition Source Data

Facility	
Clearstone Client	CCAC.4
Data Client	CCAC.4
Operator	CCAC.4
Name	CCAC.4
Location	CCAC.4
ID	CCAC.4
Category	Battery
Type	Oil Multi-Well
Government ID	CCAC.4
Operator BA Code	CCAC.4
Licensee BA Code	CCAC.4
Licensee Name	CCAC.4

Sample Data	
Name	CCAC.Comp.28
Description and Comments	CCAC.Comp.28
Data Entry Date	2014-12-10
Sample Date	N/A
Sample Type	Computed (Gas/Molar)
Substance Type	Process Gas
Clearstone ID	CCAC.Comp.28

Analysis Results			
Component Name	Mole Fraction		
	Entered	Normalized	Air Free
Benzene	0.004427	0.004427	0.004427
Cyclohexane	0.008808	0.008808	0.008808
Dodecane	0.055442	0.055442	0.055442
Ethylbenzene	0.009565	0.009565	0.009565
Hexadecane	0.035986	0.035986	0.035986
Isobutane	0.000963	0.000963	0.000963
Isopentane	0.005237	0.005237	0.005237
Methylcyclohexane	0.009264	0.009264	0.009264
Methylcyclopentane	0.005975	0.005975	0.005975
n-Butane	0.005000	0.005000	0.005000
n-Decane	0.075602	0.075602	0.075602
n-Eicosane	0.276139	0.276139	0.276139
n-Heptadecane	0.031271	0.031271	0.031271
n-Heptane	0.037619	0.037619	0.037619
n-Hexane	0.029733	0.029733	0.029733
n-Nonadecane	0.027333	0.027333	0.027333
n-Nonane	0.052094	0.052094	0.052094
n-Octane	0.054558	0.054558	0.054558
n-Pentadecane	0.042085	0.042085	0.042085
n-Pentane	0.010327	0.010327	0.010327
n-Tetradecane	0.044131	0.044131	0.044131
n-Tridecane	0.051413	0.051413	0.051413

Analysis Results			
Component Name	Mole Fraction		
	Entered	Normalized	Air Free
n-Undecane	0.063968	0.063968	0.063968
Octadecane	0.029765	0.029765	0.029765
o-Xylene	0.007875	0.007875	0.007875
Propane	0.005595	0.005595	0.005595
p-Xylene	0.007035	0.007035	0.007035
Toluene	0.012790	0.012790	0.012790
Total	1.000000	1.000000	1.000000



Composition Source Data

Facility	
Clearstone Client	CCAC.5
Data Client	CCAC.5
Operator	CCAC.5
Name	CCAC.5
Location	CCAC.5
ID	CCAC.5
Category	Battery
Type	Oil Multi-Well
Government ID	CCAC.5
Operator BA Code	CCAC.5
Licensee BA Code	CCAC.5
Licensee Name	CCAC.5

Sample Data	
Name	CCAC.Comp.13
Description and Comments	CCAC.Comp.13
Data Entry Date	2015-11-30
Sample Date	N/A
Sample Type	Computed (Gas/Molar)
Substance Type	Unknown
Clearstone ID	CCAC.Comp.13

Analysis Results			
Component Name	Mole Fraction		
	Entered	Normalized	Air Free
Carbon dioxide	0.029405	0.029405	0.029405
Ethane	0.107089	0.107089	0.107089
Isobutane	0.083205	0.083205	0.083205
Isopentane	0.093539	0.093539	0.093539
Methane	0.032527	0.032527	0.032527
n-Butane	0.252726	0.252726	0.252726
n-Hexane	0.078189	0.078189	0.078189
Nitrogen	0.000267	0.000267	0.000267
n-Pentane	0.098718	0.098718	0.098718
Propane	0.224336	0.224336	0.224336
Total	1.000001	1.000000	1.000000



Composition Source Data

Facility	
Clearstone Client	CCAC.5
Data Client	CCAC.5
Operator	CCAC.5
Name	CCAC.5
Location	CCAC.5
ID	CCAC.5
Category	Battery
Type	Oil Multi-Well
Government ID	CCAC.5
Operator BA Code	CCAC.5
Licensee BA Code	CCAC.5
Licensee Name	CCAC.5

Sample Data	
Name	CCAC.Comp.15
Description and Comments	CCAC.Comp.15
Data Entry Date	2014-12-10
Sample Date	N/A
Sample Type	Computed (Gas/Molar)
Substance Type	Waste Gas
Clearstone ID	CCAC.Comp.15

Analysis Results			
Component Name	Mole Fraction		
	Entered	Normalized	Air Free
Carbon dioxide	0.089598	0.089598	0.089598
Ethane	0.086336	0.086336	0.086336
Isobutane	0.007467	0.007467	0.007467
Isopentane	0.006549	0.006549	0.006549
Methane	0.695377	0.695377	0.695377
n-Butane	0.020575	0.020575	0.020575
n-Hexane	0.005174	0.005174	0.005174
Nitrogen	0.045100	0.045100	0.045100
n-Pentane	0.006828	0.006828	0.006828
Propane	0.036996	0.036996	0.036996
Total	1.000000	1.000000	1.000000



Composition Source Data

Facility	
Clearstone Client	CCAC.5
Data Client	CCAC.5
Operator	CCAC.5
Name	CCAC.5
Location	CCAC.5
ID	CCAC.5
Category	Battery
Type	Oil Multi-Well
Government ID	CCAC.5
Operator BA Code	CCAC.5
Licensee BA Code	CCAC.5
Licensee Name	CCAC.5

Sample Data	
Name	CCAC.Comp.27
Description and Comments	CCAC.Comp.27
Data Entry Date	2014-12-10
Sample Date	N/A
Sample Type	Computed (Gas/Molar)
Substance Type	Sales Gas
Clearstone ID	CCAC.Comp.27

Analysis Results			
Component Name	Mole Fraction		
	Entered	Normalized	Air Free
Benzene	0.004427	0.004427	0.004427
Cyclohexane	0.008808	0.008808	0.008808
Dodecane	0.055442	0.055442	0.055442
Ethylbenzene	0.009565	0.009565	0.009565
Hexadecane	0.035986	0.035986	0.035986
Isobutane	0.000963	0.000963	0.000963
Isopentane	0.005237	0.005237	0.005237
Methylcyclohexane	0.009264	0.009264	0.009264
Methylcyclopentane	0.005975	0.005975	0.005975
n-Butane	0.005000	0.005000	0.005000
n-Decane	0.075602	0.075602	0.075602
n-Eicosane	0.276139	0.276139	0.276139
n-Heptadecane	0.031271	0.031271	0.031271
n-Heptane	0.037619	0.037619	0.037619
n-Hexane	0.029733	0.029733	0.029733
n-Nonadecane	0.027333	0.027333	0.027333
n-Nonane	0.052094	0.052094	0.052094
n-Octane	0.054558	0.054558	0.054558
n-Pentadecane	0.042085	0.042085	0.042085
n-Pentane	0.010327	0.010327	0.010327
n-Tetradecane	0.044131	0.044131	0.044131
n-Tridecane	0.051413	0.051413	0.051413

Analysis Results			
Component Name	Mole Fraction		
	Entered	Normalized	Air Free
n-Undecane	0.063968	0.063968	0.063968
Octadecane	0.029765	0.029765	0.029765
o-Xylene	0.007875	0.007875	0.007875
Propane	0.005595	0.005595	0.005595
p-Xylene	0.007035	0.007035	0.007035
Toluene	0.012790	0.012790	0.012790
Total	1.000000	1.000000	1.000000



Composition Source Data

Facility	
Clearstone Client	CCAC.6
Data Client	CCAC.6
Operator	CCAC.6
Name	CCAC.6
Location	CCAC.6
ID	CCAC.6
Category	Battery
Type	Oil Multi-Well
Government ID	CCAC.6
Operator BA Code	CCAC.6
Licensee BA Code	CCAC.6
Licensee Name	CCAC.6

Sample Data	
Name	CCAC.Comp.19
Description and Comments	CCAC.Comp.19
Data Entry Date	2014-12-10
Sample Date	N/A
Sample Type	Computed (Gas/Molar)
Substance Type	Waste Gas
Clearstone ID	CCAC.Comp.19

Analysis Results			
Component Name	Mole Fraction		
	Entered	Normalized	Air Free
Carbon dioxide	0.255839	0.255839	0.255839
Ethane	0.118923	0.118923	0.118923
Isobutane	0.015330	0.015330	0.015330
Isopentane	0.009896	0.009896	0.009896
Methane	0.392249	0.392249	0.392249
n-Butane	0.038813	0.038813	0.038813
n-Hexane	0.005209	0.005209	0.005209
Nitrogen	0.048181	0.048181	0.048181
n-Pentane	0.010390	0.010390	0.010390
Propane	0.105169	0.105169	0.105169
Total	1.000000	1.000000	1.000000



Composition Source Data

Facility	
Clearstone Client	CCAC.6
Data Client	CCAC.6
Operator	CCAC.6
Name	CCAC.6
Location	CCAC.6
ID	CCAC.6
Category	Battery
Type	Oil Multi-Well
Government ID	CCAC.6
Operator BA Code	CCAC.6
Licensee BA Code	CCAC.6
Licensee Name	CCAC.6

Sample Data	
Name	CCAC.Comp.25
Description and Comments	CCAC.Comp.25
Data Entry Date	2014-12-10
Sample Date	N/A
Sample Type	Computed (Gas/Molar)
Substance Type	Tank Vapour
Clearstone ID	CCAC.Comp.25

Analysis Results			
Component Name	Mole Fraction		
	Entered	Normalized	Air Free
Benzene	0.004427	0.004427	0.004427
Cyclohexane	0.008808	0.008808	0.008808
Dodecane	0.055442	0.055442	0.055442
Ethylbenzene	0.009565	0.009565	0.009565
Hexadecane	0.035986	0.035986	0.035986
Isobutane	0.000963	0.000963	0.000963
Isopentane	0.005237	0.005237	0.005237
Methylcyclohexane	0.009264	0.009264	0.009264
Methylcyclopentane	0.005975	0.005975	0.005975
n-Butane	0.005000	0.005000	0.005000
n-Decane	0.075602	0.075602	0.075602
n-Eicosane	0.276139	0.276139	0.276139
n-Heptadecane	0.031271	0.031271	0.031271
n-Heptane	0.037619	0.037619	0.037619
n-Hexane	0.029733	0.029733	0.029733
n-Nonadecane	0.027333	0.027333	0.027333
n-Nonane	0.052094	0.052094	0.052094
n-Octane	0.054558	0.054558	0.054558
n-Pentadecane	0.042085	0.042085	0.042085
n-Pentane	0.010327	0.010327	0.010327
n-Tetradecane	0.044131	0.044131	0.044131
n-Tridecane	0.051413	0.051413	0.051413

Analysis Results			
Component Name	Mole Fraction		
	Entered	Normalized	Air Free
n-Undecane	0.063968	0.063968	0.063968
Octadecane	0.029765	0.029765	0.029765
o-Xylene	0.007875	0.007875	0.007875
Propane	0.005595	0.005595	0.005595
p-Xylene	0.007035	0.007035	0.007035
Toluene	0.012790	0.012790	0.012790
Total	1.000000	1.000000	1.000000



Composition Source Data

Facility	
Clearstone Client	CCAC.7
Data Client	CCAC.7
Operator	CCAC.7
Name	CCAC.7
Location	CCAC.7
ID	CCAC.7
Category	Compressor Station
Type	Gas Transmission
Government ID	CCAC.7
Operator BA Code	CCAC.7
Licensee BA Code	CCAC.7
Licensee Name	CCAC.7

Sample Data	
Name	CCAC.Comp.20
Description and Comments	CCAC.Comp.20
Data Entry Date	2014-12-10
Sample Date	N/A
Sample Type	As Sampled (Gas/Molar)
Substance Type	Fuel Gas
Clearstone ID	CCAC.Comp.20

Analysis Results			
Component Name	Mole Fraction		
	Entered	Normalized	Air Free
Carbon dioxide	0.000820	0.000820	0.000820
Ethane	0.085050	0.085051	0.085051
Isobutane	0.000490	0.000490	0.000490
Isopentane	0.000160	0.000160	0.000160
Methane	0.863010	0.863019	0.863019
n-Butane	0.000900	0.000900	0.000900
n-Hexane	0.000080	0.000080	0.000080
Nitrogen	0.042360	0.042360	0.042360
n-Pentane	0.000160	0.000160	0.000160
Propane	0.006960	0.006960	0.006960
Total	0.999990	1.000000	1.000000



Composition Source Data

Facility	
Clearstone Client	CCAC.7
Data Client	CCAC.7
Operator	CCAC.7
Name	CCAC.7
Location	CCAC.7
ID	CCAC.7
Category	Compressor Station
Type	Gas Transmission
Government ID	CCAC.7
Operator BA Code	CCAC.7
Licensee BA Code	CCAC.7
Licensee Name	CCAC.7

Sample Data	
Name	CCAC.Comp.31
Description and Comments	CCAC.Comp.31
Data Entry Date	2014-12-10
Sample Date	N/A
Sample Type	Computed (Gas/Molar)
Substance Type	Waste Gas
Clearstone ID	CCAC.Comp.31

Analysis Results			
Component Name	Mole Fraction		
	Entered	Normalized	Air Free
Carbon dioxide	0.032000	0.032000	0.032000
Ethane	0.112400	0.112400	0.112400
Hydrogen sulfide	0.022400	0.022400	0.022400
Isobutane	0.006800	0.006800	0.006800
Isopentane	0.003700	0.003700	0.003700
Methane	0.646200	0.646200	0.646200
n-Butane	0.017500	0.017500	0.017500
n-Hexane	0.002200	0.002200	0.002200
Nitrogen	0.097400	0.097400	0.097400
n-Pentane	0.004500	0.004500	0.004500
Propane	0.054900	0.054900	0.054900
Total	1.000000	1.000000	1.000000